

PARTS CATALOGUE

YZ450FD (33DD) U.S.A.



1M33D-110E1

()

YZ450FD
PARTS CATALOGUE
©2012 by Yamaha Motor Co., Ltd.
1st edition, June 2012
All rights reserved.
Any reprinting or unauthorized use
without the written permission of
Yamaha Motor Co., Ltd.
is expressly prohibited.
Printed in Japan.

FOREWORD

This Parts Catalogue is related to the parts for the model(s) on the cover page. When you are ordering replacement parts, please refer to this Parts Catalogue and quote both part numbers and part names correctly.

1. Modifications or additions which have been made after the issue of the Parts Catalogue will be announced in the Parts News.

It is advisable that you make the necessary corrections to the Parts Catalogue according to the Parts News.

2. Abbreviations

The following abbreviations are used in this Parts Catalogue.

“UR” Use specified parts number.

“UN” Use as many as needed.

“AP” Alternate Parts

“LM” Locally Made (Parts need to be ordered locally)

“F#” Frame No. (Applicable machine No.)

“O/S” Over Size

3. The number of components for assembly

- Parts, which are to be supplied in an assembly, are listed with a dot (.) in front of the part name as shown below.
- The numeral appearing to the right of each component part indicates the quantity of parts for each assembly unit.

PART NO.	DESCRIPTION	Q'TY	REMARKS
2F5-83310-60	FRONT FLASHER LIGHT ASSY	2	
115-83311-60	.BULB (6V-18W)	1	

4. Applicable colours of graphics are represented in the “REMARKS” as shown below.

PART NO.	DESCRIPTION	Q'TY	REMARKS
2N4-24110-00-X5	FUEL TANK COMP.	2	MXR
3J1-24240-10	.GRAPHIC, FUEL TANK	1	FOR MXR

5. Note that the illustrations for reference in finding parts numbers are not to be used for assembling. When assembling, please use the applicable service manual.

6. The asterisk (*) before a reference number indicates modified items after the first edition.

CONTENTS

ENGINE

CYLINDER	1
CRANKSHAFT & PISTON	3
VALVE	4
CAMSHAFT & CHAIN	6
WATER PUMP	7
RADIATOR & HOSE	8
OIL PUMP	9
OIL CLEANER	10
INTAKE	11
INTAKE 2	13
EXHAUST	14
CRANKCASE	15
CRANKCASE COVER 1	17
STARTER	19
CLUTCH	20
TRANSMISSION	21
SHIFT CAM & FORK	23
SHIFT SHAFT	24

CHASSIS

FRAME	25
FENDER	28
SIDE COVER	29
REAR ARM	31
REAR SUSPENSION	33
STEERING	34
FRONT FORK	35
FUEL TANK	38
SEAT	40
FRONT WHEEL	41
FRONT BRAKE CALIPER	42
REAR WHEEL	43
REAR BRAKE CALIPER	45
STEERING HANDLE & CABLE	46
FRONT MASTER CYLINDER	47
STAND & FOOTREST	48
REAR MASTER CYLINDER	49
GENERATOR	50
HANDLE SWITCH & LEVER	51
ELECTRICAL 1	52
ALTERNATE FOR CHASSIS	54

INDEX

NUMERICAL INDEX	55
-----------------------	----

FIG. 1 CYLINDER

REF. NO.	PART NO.	DESCRIPTION	33DD				REMARKS
1	33D-11102-00	CYLINDER HEAD ASSY	1				
2	5PS-11133-10	.GUIDE, VALVE 1	2				
3	5PS-11134-10	.GUIDE, VALVE 2	2				
4	90105-06027	.BOLT, FLANGE	8				
5	90340-12007	.PLUG, STRAIGHT SCREW	2				
6	91808-16023	.PIN, DOWEL	2				
7	91808-16023	.PIN, DOWEL	2				
8	95022-08012	BOLT, FLANGE	1				
9	90430-08119	GASKET	1				
10	95022-06010	BOLT, FLANGE	2				
11	90430-06014	GASKET	2				
12	90116-06037	BOLT, STUD	3				
13	94701-00411	PLUG, SPARK (NGK R CR8E)	1				STD
	94701-00410	PLUG, SPARK (NGK R CR9E)	1				AP
14	33D-11181-00	GASKET, CYLINDER HEAD 1	1				
15	93612-16254	PIN, DOWEL	2				
16	90105-10367	BOLT, FLANGE	4				
17	90201-10025	WASHER, PLATE	4				
18	95022-06035	BOLT, FLANGE	2				
19	33D-11191-10	COVER, CYLINDER HEAD 1	1				
20	5BE-12241-00	GUIDE, STOPPER 2	1				
21	33D-11193-01	GASKET, HEAD COVER 1	1				
22	371-11167-01	PIPE, BREATHER 2	1				
23	33D-11166-00	PIPE, BREATHER 1	1				
24	90467-140A4	CLIP	1				
25	5UM-1119E-00	BOLT, COVER HEAD	2				
26	33D-1119E-00	BOLT, COVER HEAD	1				

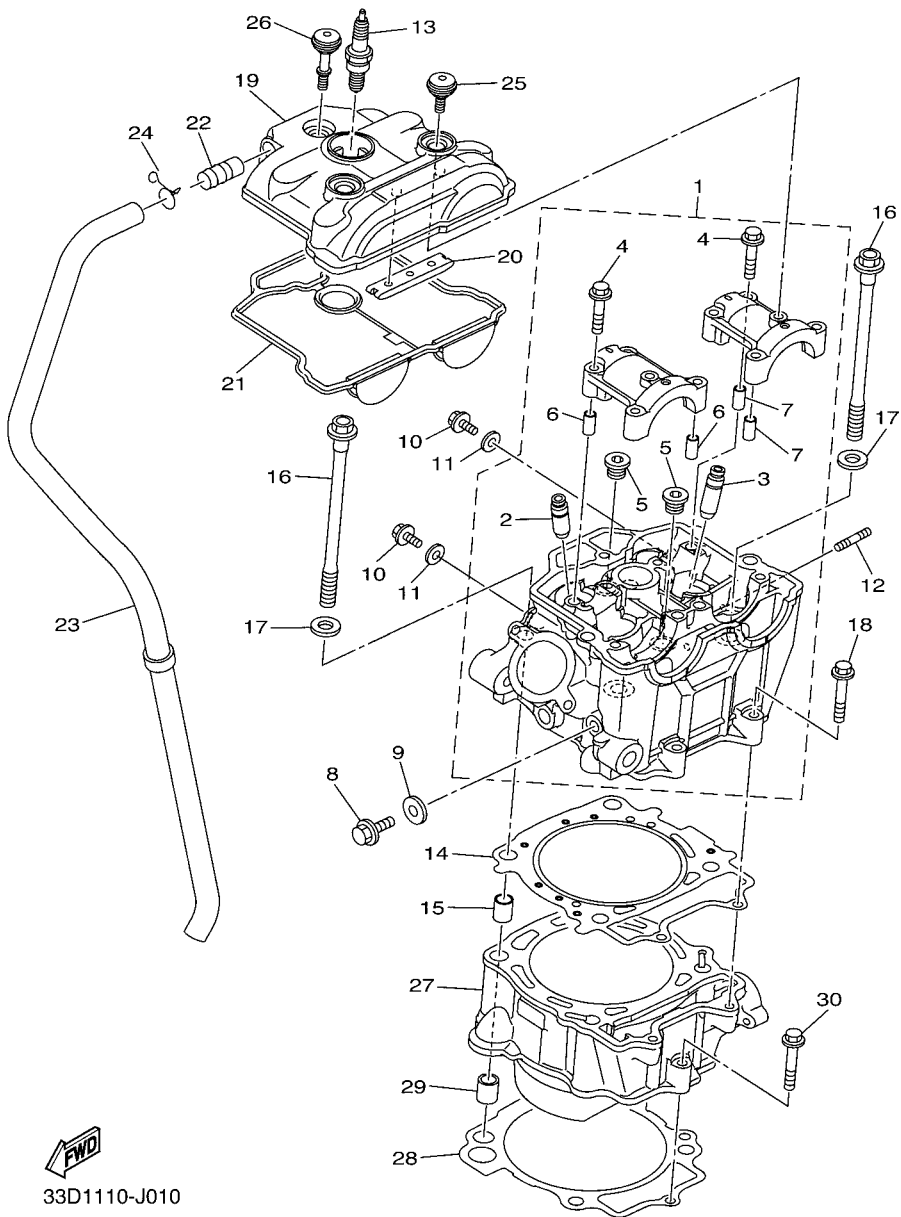

33D1110-J010

FIG. 1 CYLINDER

REF. NO.	PART NO.	DESCRIPTION	33DD			REMARKS
27	33D-11311-10	CYLINDER 1	1			
28	33D-11351-00	GASKET, CYLINDER	1			
29	99530-14016	PIN, DOWEL	2			
30	95022-06035	BOLT, FLANGE	1			

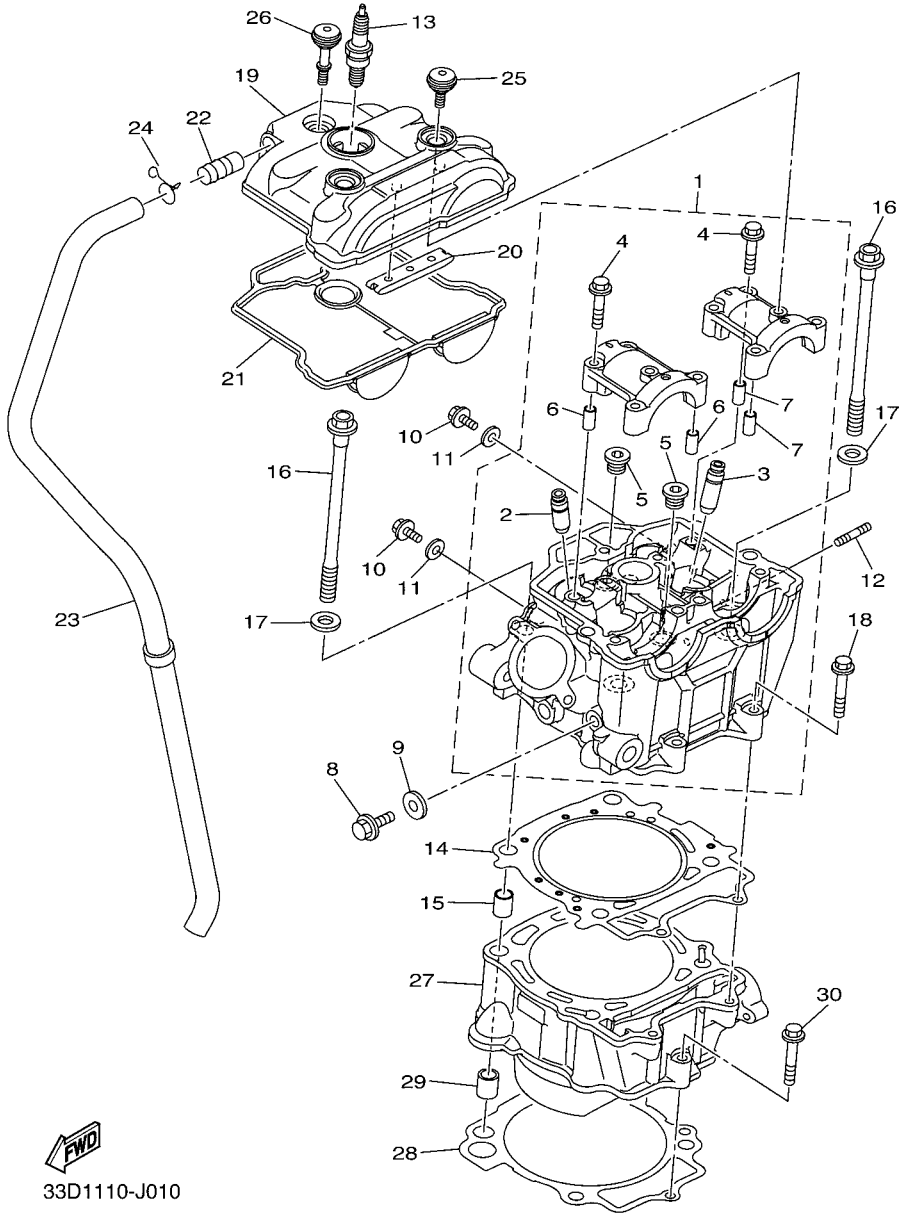

FWD
33D1110-J010

FIG. 2 CRANKSHAFT & PISTON

REF. NO.	PART NO.	DESCRIPTION	33DD				REMARKS
1	33D-11400-01	CRANKSHAFT ASSY	1				
2	33D-11412-00	.CRANK 1	1				
3	33D-11422-00	.CRANK 2	1				
4	5TG-11681-01	.PIN, CRANK 1	1				
5	93310-63458	.BEARING	1				
6	33D-11651-00	.ROD, CONNECTING	1				
7	93306-30633	BEARING	2				
8	33D-11536-00	GEAR, DRIVE	1				
9	33D-11455-00	SHAFT 1	1				
10	93304-20310	BEARING	2				
11	2S2-11531-00	GEAR, BALANCE WEIGHT	1				
12	90170-14171	NUT	1				
13	90215-14287	WASHER, LOCK	1				
14	33D-11454-00	WEIGHT 1	1				
15	90149-06083	SCREW	3				
16	33D-11464-00	WEIGHT 2	1				
17	90282-05034	KEY, STRAIGHT	1				
18	90170-10405	NUT	1				
19	90215-10009	WASHER, LOCK	1				
20	90280-03006	KEY, WOODRUFF	1				
21	33D-116A0-00	PISTON ASSY	1				
22	33D-11631-00	.PISTON (STD)	1				
23	33D-11603-00	.PISTON RING SET (STD)	1				
24	33D-11633-00	.PIN, PISTON	1				
25	93450-19052	.CIRCLIP	2				

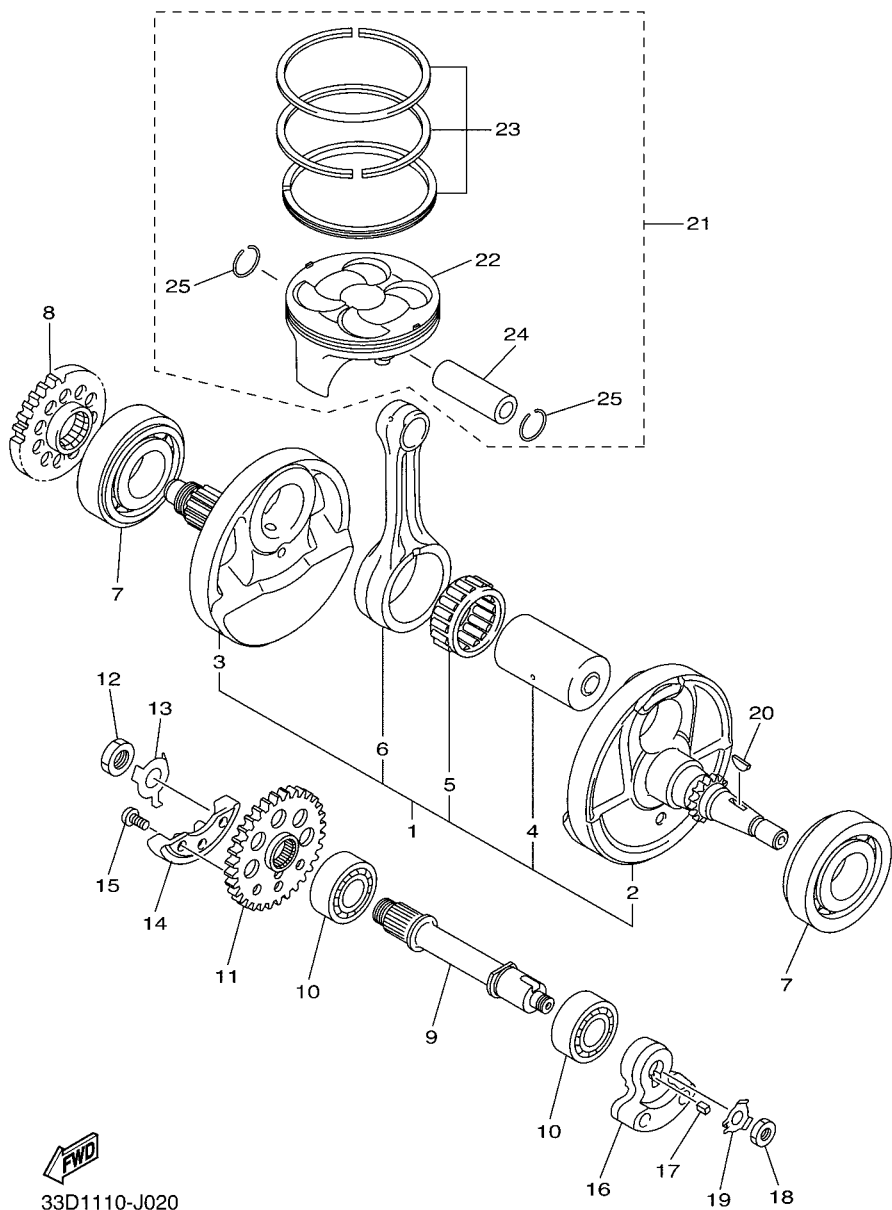

33D1110-J020

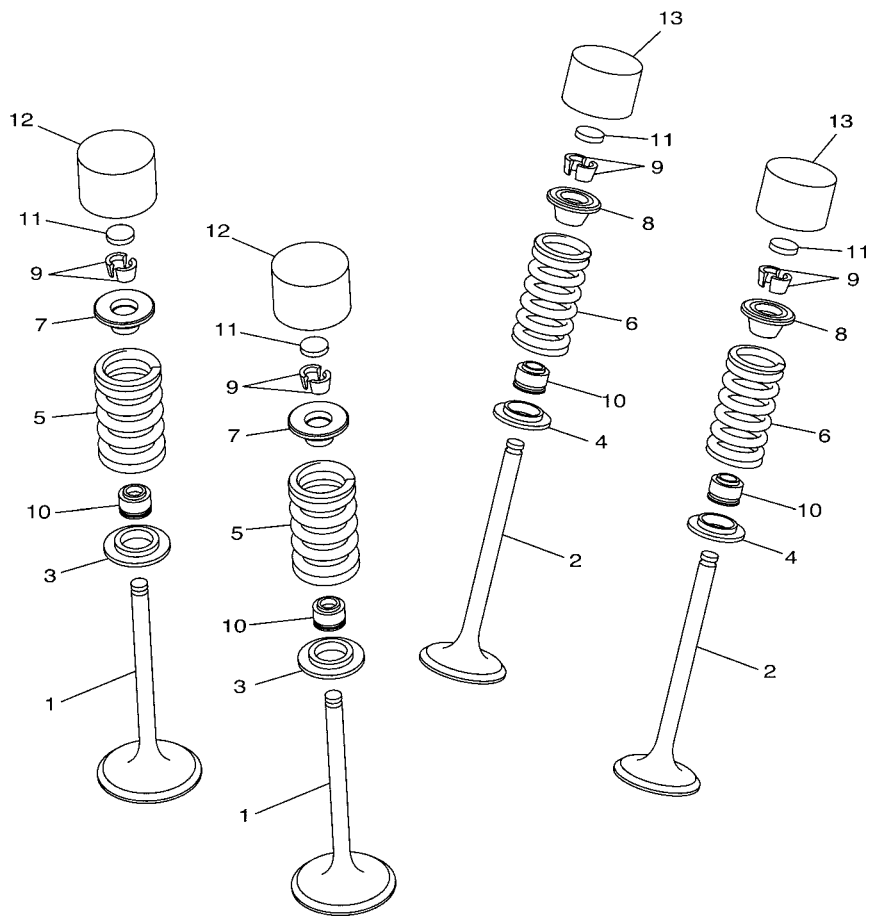

33D1110-J030

FIG. 3 VALVE

REF. NO.	PART NO.	DESCRIPTION	33DD			REMARKS
1	33D-12111-00	VALVE, INTAKE	2			
2	33D-12121-00	VALVE, EXHAUST	2			
3	33D-12116-00	SEAT, VALVE SPRING	2			
4	33D-12126-00	SEAT, VALVE SPRING 2	2			
5	33D-12113-00	SPRING, VALVE INNER	2			
6	33D-12114-00	SPRING, VALVE OUTER	2			
7	33D-12117-00	RETAINER, VALVE SPRING	2			
8	3LD-12117-00	RETAINER, VALVE SPRING	2			
9	3LD-12118-00	COTTER, VALVE	8			
10	51Y-12119-00	SEAL, VALVE STEM	4			
11	3LD-12168-00	PAD, ADJUSTING (1.20)	4			UR
	3LD-12168-20	PAD, ADJUSTING (1.25)	4			UR
	3LD-12168-40	PAD, ADJUSTING (1.30)	4			UR
	3LD-12168-60	PAD, ADJUSTING (1.35)	4			UR
	3LD-12168-80	PAD, ADJUSTING (1.40)	4			UR
	3LD-12168-A0	PAD, ADJUSTING (1.45)	4			UR
	3LD-12168-F0	PAD, ADJUSTING (1.50)	4			UR
	3LD-12168-H1	PAD, ADJUSTING (1.55)	4			UR
	3LD-12168-K1	PAD, ADJUSTING (1.60)	4			UR
	3LD-12168-M1	PAD, ADJUSTING (1.65)	4			UR
	3LD-12168-R1	PAD, ADJUSTING (1.70)	4			UR
	3LD-12168-U1	PAD, ADJUSTING (1.75)	4			UR
	3LD-12168-W1	PAD, ADJUSTING (1.80)	4			UR
	3LD-12168-Y1	PAD, ADJUSTING (1.85)	4			UR
	3LD-12169-11	PAD, ADJUSTING (1.90)	4			UR
	3LD-12169-31	PAD, ADJUSTING (1.95)	4			UR
	3LD-12169-50	PAD, ADJUSTING (2.00)	4			UR

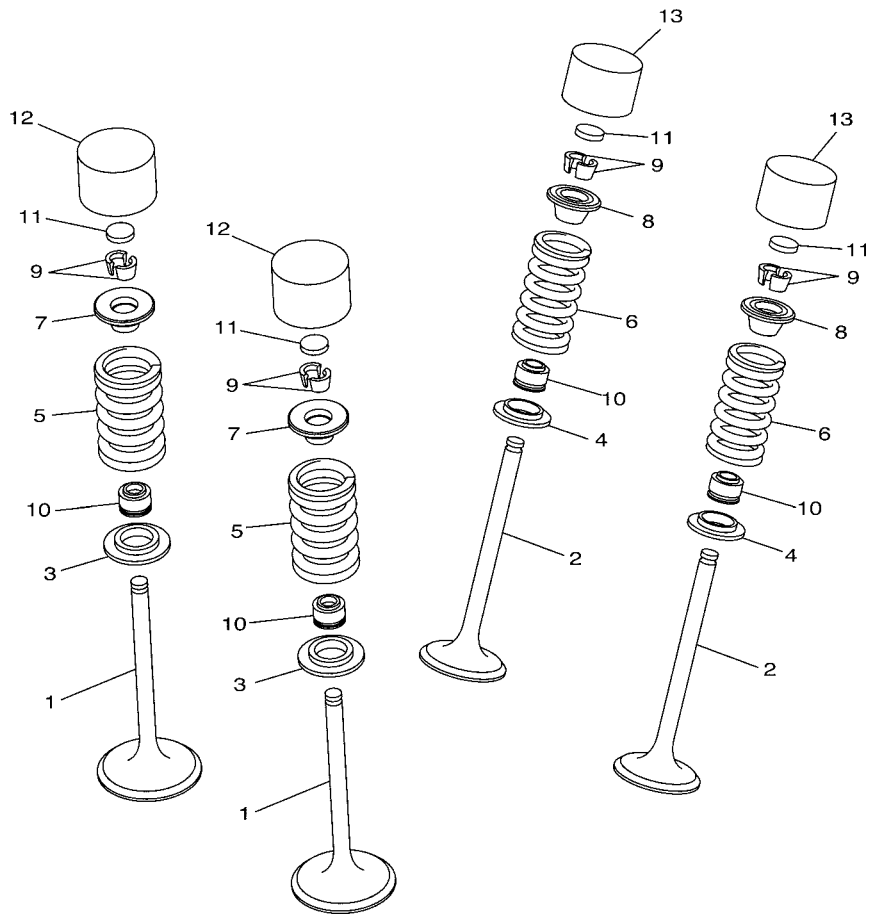

33D1110-J030

FIG. 3 VALVE

REF. NO.	PART NO.	DESCRIPTION	33DD			REMARKS
11	3LD-12169-70	PAD, ADJUSTING (2.05)	4			UR
	3LD-12169-90	PAD, ADJUSTING (2.10)	4			UR
	3LD-12169-E0	PAD, ADJUSTING (2.15)	4			UR
	3LD-12169-G0	PAD, ADJUSTING (2.20)	4			UR
	3LD-12169-J0	PAD, ADJUSTING (2.25)	4			UR
	3LD-12169-L0	PAD, ADJUSTING (2.30)	4			UR
	3LD-12169-N0	PAD, ADJUSTING (2.35)	4			UR
	3LD-12169-T0	PAD, ADJUSTING (2.40)	4			UR
12	4C8-12153-10	LIFTER, VALVE	2			YELLOW
13	5EB-12153-10	LIFTER, VALVE	2			YELLOW
<hr/>						
<hr/>						
<hr/>						
<hr/>						
<hr/>						

FIG. 4 CAMSHAFT & CHAIN

REF. NO.	PART NO.	DESCRIPTION	33DD				REMARKS
1	33D-12170-00	CAMSHAFT ASSY 1	1				
2	33D-12180-00	CAMSHAFT ASSY 2	1				
3	93440-41178	CIRCLIP	2				
4	94591-57122	CHAIN	1				
5	5TA-12210-30	TENSIONER ASSY, CAM CHAIN	1				
6	5EL-12228-00	.BOLT	1				
7	5EL-12214-00	.GASKET	1				
8	4FM-12213-00	GASKET, TENSIONER CASE	1				
9	95022-06025	BOLT, FLANGE	2				
10	90430-06014	GASKET	1				
11	33D-12251-00	DAMPER, CHAIN 1	1				
12	33D-12252-00	DAMPER, CHAIN 2	1				
13	33D-12233-00	PLATE, GUIDE STOPPER 1	1				
14	90105-06099	BOLT, FLANGE	2				

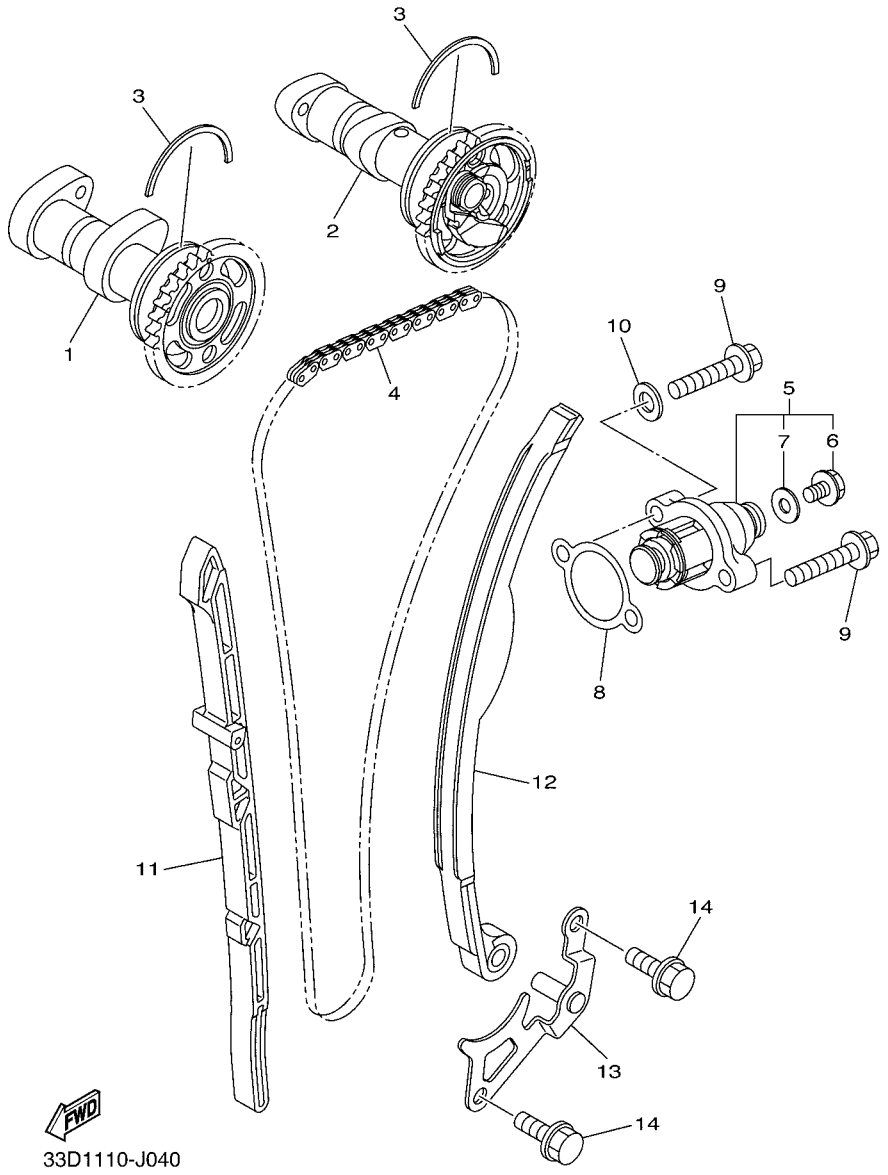

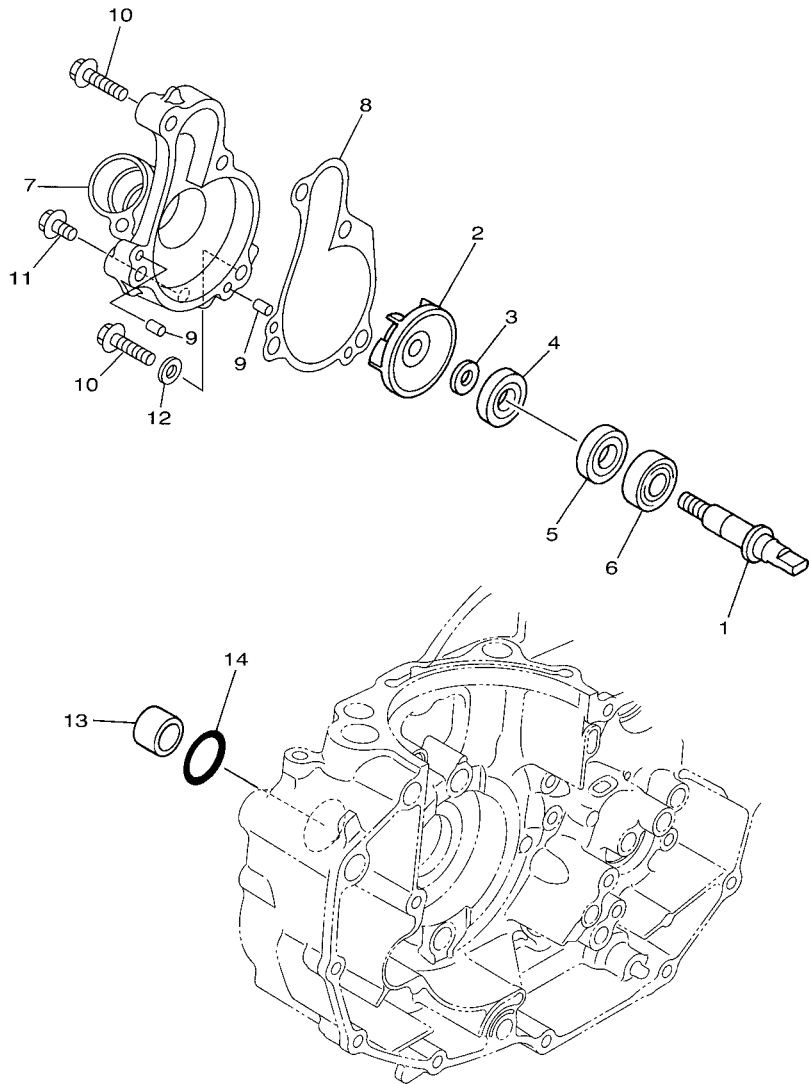

33D1110-J050

FIG. 5 WATER PUMP

REF. NO.	PART NO.	DESCRIPTION	33DD				REMARKS
1	5GR-12458-00	SHAFT, IMPELLER	1				
2	5DJ-12451-00	IMPELLER, WATER PUMP	1				
3	90201-08512	WASHER, PLATE	1				
4	93109-11073	OIL SEAL	1				
5	93102-12106	OIL SEAL (SD 12-22-5 HS)	1				
6	93306-00105	BEARING	1				
7	33D-12422-00	COVER, HOUSING	1				
8	33D-12427-00	GASKET, HOUSING COVER 1	1				
9	93604-10011	PIN, DOWEL	2				
10	95022-06025	BOLT, FLANGE	4				
11	95022-06010	BOLT, FLANGE	1				
12	90430-06014	GASKET	1				
13	5BE-12564-00	PIPE, WATER	1				
14	93210-19758	O-RING	1				

FIG. 6 RADIATOR & HOSE

REF. NO.	PART NO.	DESCRIPTION	33DD				REMARKS
1	33D-12446-00	JOINT	1				
2	93210-24253	O-RING	1				
3	95022-06020	BOLT, FLANGE	1				
4	33D-12482-00	PIPE 2	1				
5	95022-06012	BOLT, FLANGE	1				
6	93210-16500	O-RING	1				
7	33D-1240A-00	RADIATOR ASSY	1				
8	33D-12461-00	RADIATOR COMP	1				
9	5SL-12462-00	CAP, RADIATOR	1				
10	33D-12465-00	DAMPER, RADIATOR	3				
11	91A20-05065	TUBE, FLEXIBLE VINYL	1				
12	90467-090A2	CLIP	1				
13	33D-12576-00	HOSE 1	1				
14	33D-12577-00	HOSE 2	1				
15	33D-12578-00	HOSE 3	1				
16	33D-12579-00	HOSE 4	1				
17	90450-28001	HOSE CLAMP ASSY	2				
18	90450-25001	HOSE CLAMP ASSY	3				
19	90450-22001	HOSE CLAMP ASSY	2				
20	90450-32003	HOSE CLAMP ASSY	1				
21	90480-15012	GROMMET	4				
22	90387-06065	COLLAR	4				
23	90105-06111	BOLT, FLANGE	4				
24	90201-06571	WASHER, PLATE	4				
25	90119-06239	BOLT, WITH WASHER	2				

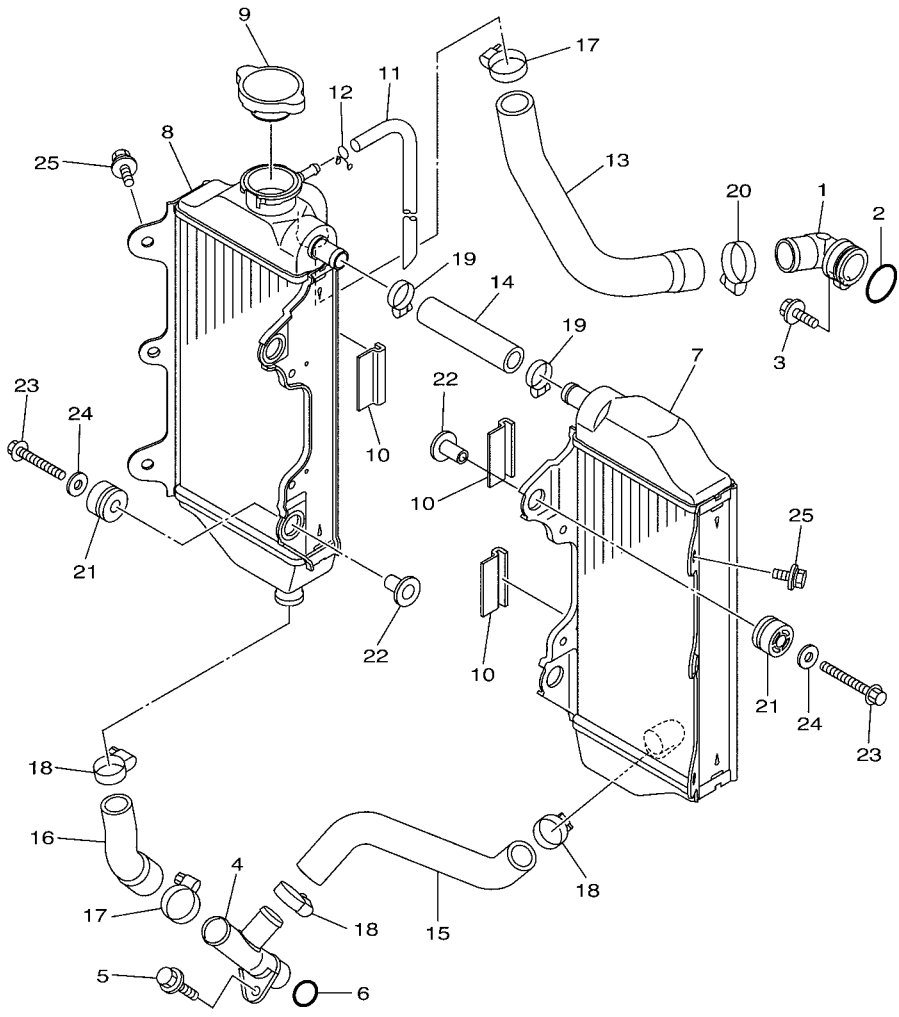

33D1110-J060

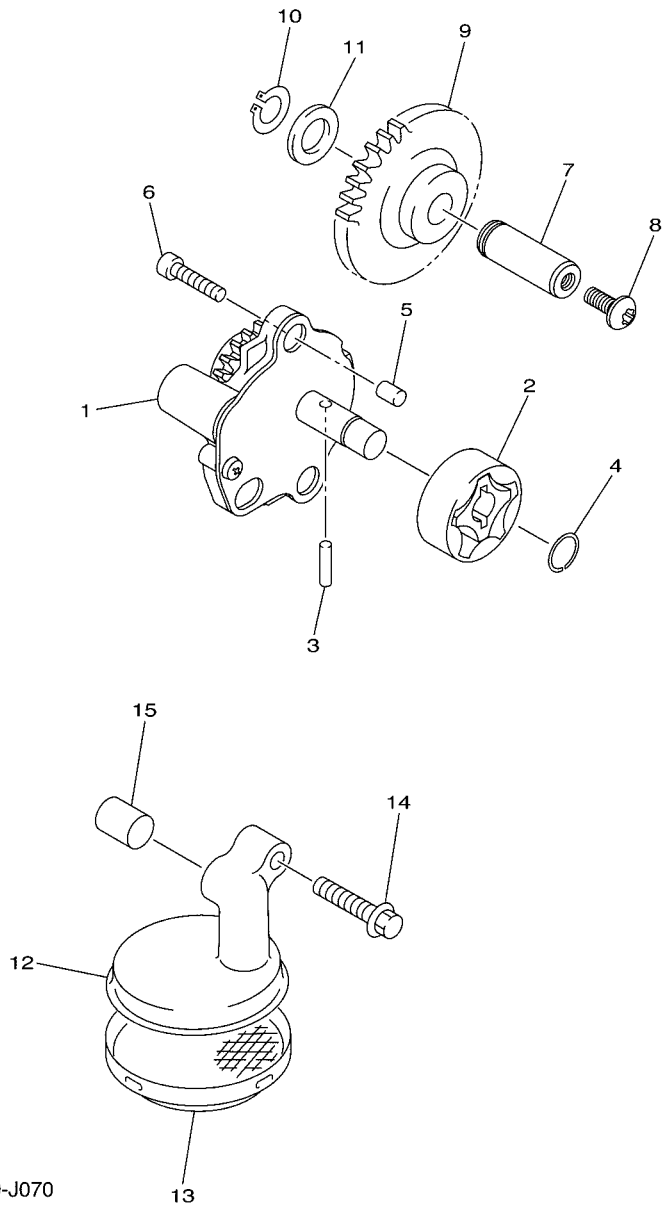

33D1110-J070

FIG. 7 OIL PUMP

REF. NO.	PART NO.	DESCRIPTION	33DD				REMARKS
1	2S2-13300-10	OIL PUMP ASSY	1				
2	5TA-13320-00	ROTOR ASSY 2	1				
3	93603-16219	PIN, DOWEL	1				
4	93440-10153	CIRCLIP	1				
5	99530-08012	PIN, DOWEL	2				
6	91312-06030	BOLT	2				
7	2S2-13342-00	SHAFT, IDLE GEAR	1				
8	90149-06069	SCREW	1				
9	2S2-13341-00	GEAR, OIL PUMP IDLE	1				
10	99009-12400	CIRCLIP	1				
11	90201-12166	WASHER, PLATE	1				
12	2S2-13412-00	HOUSING, STRAINER	1				
13	5BE-13411-00	STRAINER, OIL	1				
14	90105-06091	BOLT, FLANGE	1				
15	99530-10114	PIN, DOWEL	1				

FIG. 8 OIL CLEANER

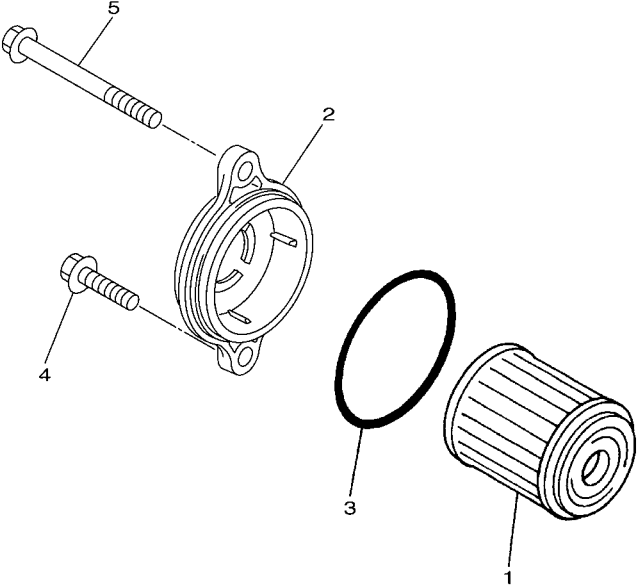

REF. NO.	PART NO.	DESCRIPTION	33DD					REMARKS
1	5D3-13440-01	ELEMENT ASSY, OIL CLEANER	1					
2	33D-13447-00	COVER, OIL ELEMENT	1					
3	93210-45708	O-RING	1					
4	95022-06016	BOLT, FLANGE	1					
5	95022-06070	BOLT, FLANGE	1					

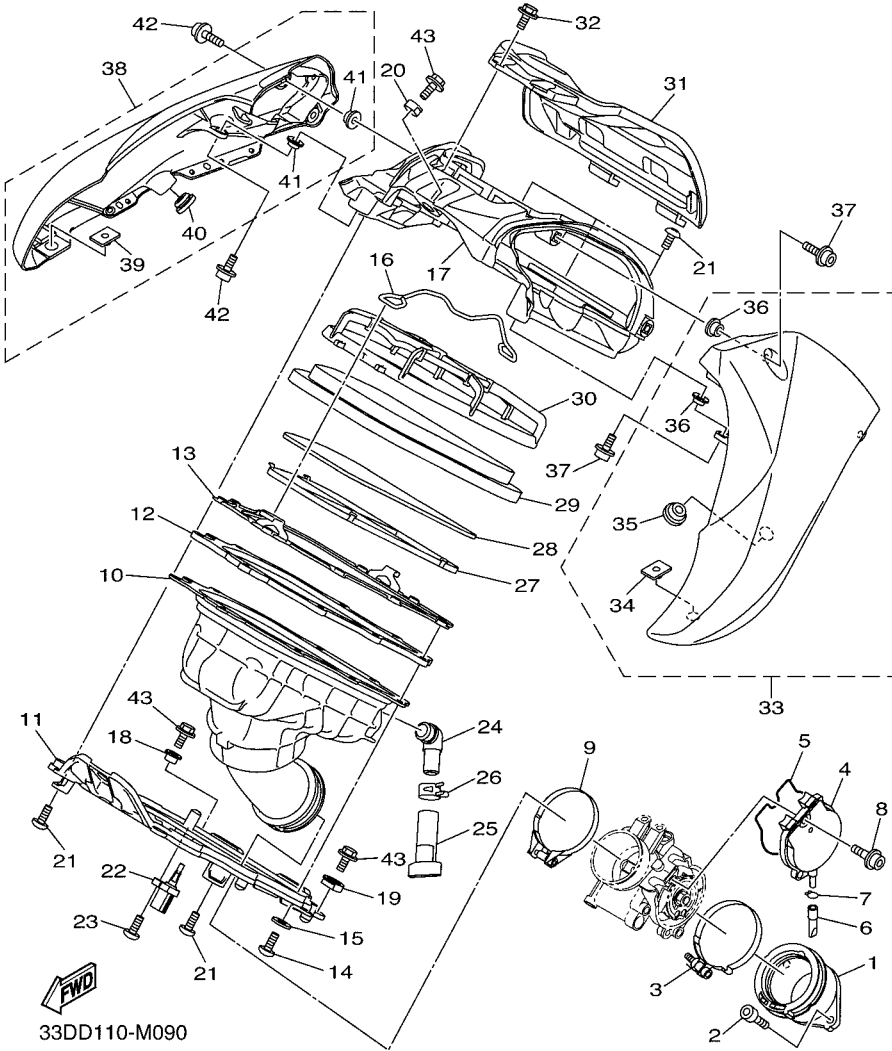
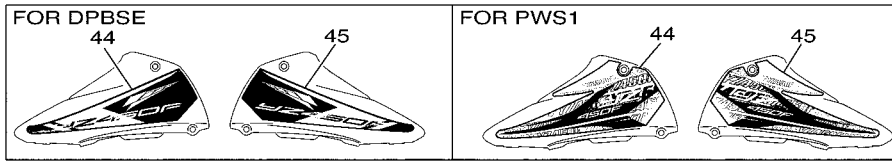

33DD110-M090

FIG. 9 INTAKE

REF. NO.	PART NO.	DESCRIPTION	33DD				REMARKS
1	33D-13597-00	JOINT, CARBURETOR 3	1				
2	91312-06020	BOLT	2				
3	90450-60004	HOSE CLAMP ASSY	1				
4	33D-14293-00	COVER 1	1				
5	33D-14227-00	WASHER	1				
6	33D-14987-00	HOSE	1				
7	3TJ-14137-40	CLIP	1				
8	33D-14428-00	BOLT	2				
9	90450-58007	HOSE CLAMP ASSY	1				
10	33D-14454-00	JOINT	1				
11	33D-14477-00	PLATE	1				
12	33D-14462-00	SEAL	1				
13	33D-14459-00	HOLDER, GUIDE	1				
14	90111-04008	BOLT, HEX. SOCKET BUTTON	9				
15	90201-04030	WASHER, PLATE	9				
16	33D-1441G-00	BINDER 1	1				
17	33D-14417-00	COVER 1	1				
18	90387-06009	COLLAR	1				
19	33D-14495-00	COLLAR	1				
20	33D-14449-00	COLLAR	1				
21	97702-50516	SCREW, TAPPING	9				
22	8FP-85886-00	SENSOR, AIR TEMPERATURE	1				
23	97702-50516	SCREW, TAPPING	1				
24	5TJ-14419-00	PIPE	1				
25	33D-1443E-00	PIPE, DRAIN	1				
26	90467-16098	CLIP	1				
27	33D-1441B-00	NET 1	1				

FIG. 9 INTAKE

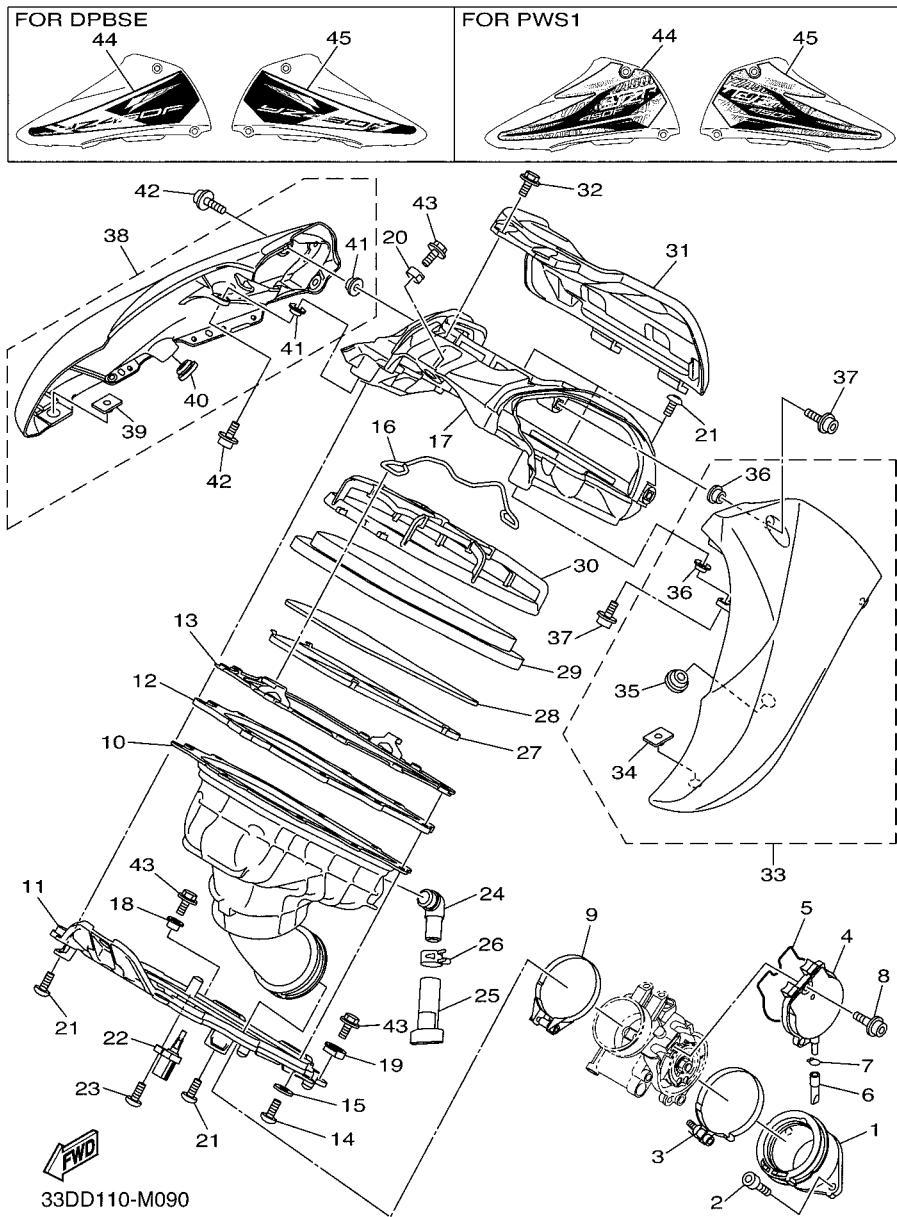

REF. NO.	PART NO.	DESCRIPTION	33DD			REMARKS
28	33D-14461-00	ELEMENT, AIR CLEANER 2	1			
29	33D-14451-00	ELEMENT, AIR CLEANER	1			
30	33D-14458-00	GUIDE	1			
31	33D-14480-00	COVER SUB ASSY	1			
32	90105-05028	BOLT, FLANGE	2			
33	33D-14437-00	DUCT	1			UR FOR DPBSE
	33D-14437-10	DUCT	1			UR FOR PWS1
34	90179-06055	.NUT	1			
35	33D-14425-00	.DAMPER 1	1			
36	90387-06009	.COLLAR	3			
37	90110-06245	BOLT, HEXAGON SOCKET HEAD	3			
38	33D-1443A-00	DUCT	1			UR FOR DPBSE
	33D-1443A-10	DUCT	1			UR FOR PWS1
39	90179-06055	.NUT	1			
40	33D-14425-00	.DAMPER 1	1			
41	90387-06009	.COLLAR	3			
42	90110-06245	BOLT, HEXAGON SOCKET HEAD	3			
43	90105-06170	BOLT, FLANGE	3			
44	33D-2173E-50	GRAPHIC 1	1			UR FOR DPBSE
	33D-2173E-60	GRAPHIC 1	1			UR FOR PWS1
45	33D-2173F-50	GRAPHIC 2	1			UR FOR DPBSE
	33D-2173F-60	GRAPHIC 2	1			UR FOR PWS1

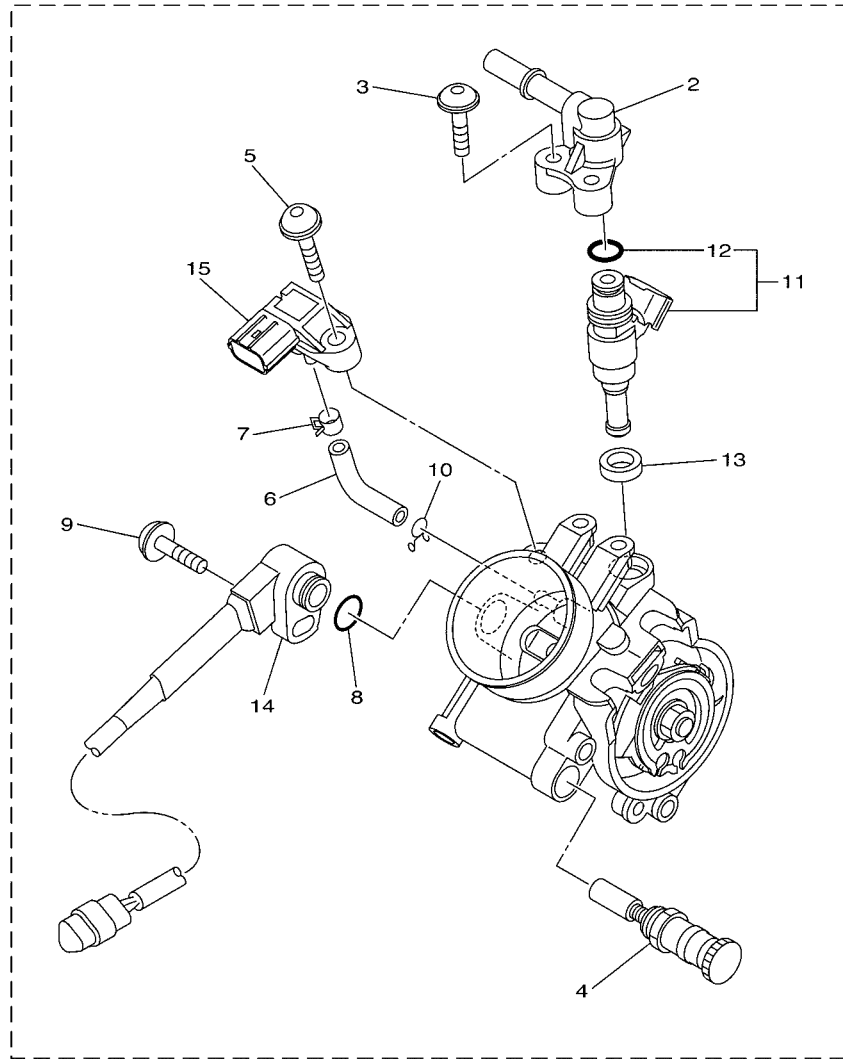

33D1110-J100

FIG. 10 INTAKE 2

REF. NO.	PART NO.	DESCRIPTION	33DD				REMARKS
1	33D-13750-00	THROTTLE BODY ASSY	1				
2	33D-13938-00	.PIPE	1				
3	33D-14486-00	.SCREW, ROD	2				
4	33D-14171-00	.PLUNGER, STARTER	1				
5	33D-14325-00	.SCREW, PAN HEAD	1				
6	33D-14348-00	.PIPE 1	1				
7	33D-13577-00	.CLIP	1				
8	33D-14562-00	.O-RING	1				
9	33D-14216-00	.SCREW	1				
10	3TJ-14137-40	.CLIP	1				
11	3B4-13761-00	.INJECTOR	1				
12	5PS-14147-00	.O-RING	1				
13	90430-09002	.GASKET	1				
14	33D-85885-00	.THROTTLE SENSOR ASSY	1				
15	2C0-82380-00	.SENSOR, PRESSURE	1				

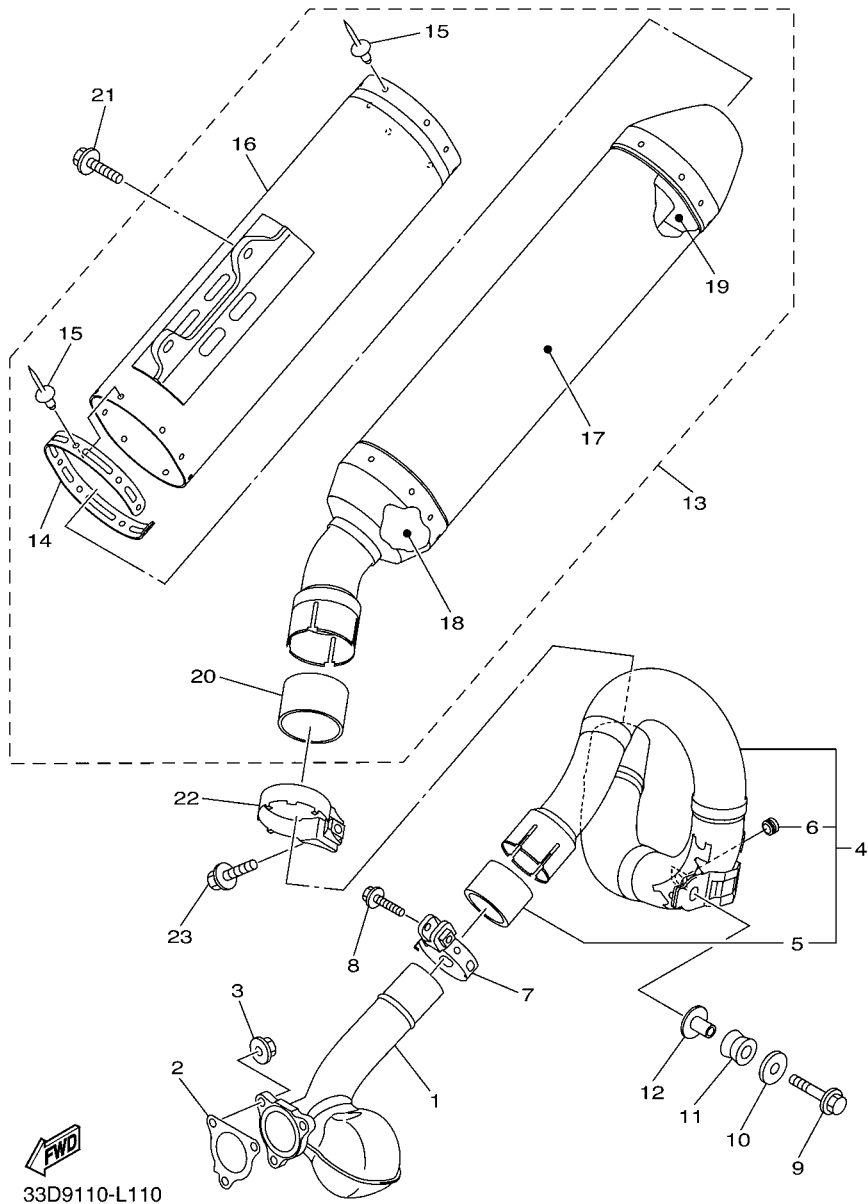

33D9110-L110

FIG. 11 EXHAUST

REF. NO.	PART NO.	DESCRIPTION	33DD				REMARKS
1	33D-14611-00	PIPE, EXHAUST 1	1				
2	33D-14613-00	GASKET, EXHAUST PIPE	1				
3	95704-06500	NUT, FLANGE	3				
4	33D-14620-00	EXHAUST PIPE ASSY 2	1				
5	5PH-14714-00	.GASKET, MUFFLER	1				
6	2D1-14737-00	.DAMPER, MUFFLER	1				
7	33D-14788-00	BAND, SILENCER	1				
8	95024-08035	BOLT, FLG.(SMALL HEAD)	1				
9	90105-08137	BOLT, FLANGE	1				
10	90201-08061	WASHER, PLATE	1				
11	5VY-14747-00	DAMPER, MUFFLER	1				
12	90387-08081	COLLAR	1				
13	33D-14750-10	SILENCER ASSY	1				
14	33D-1476F-10	.REINF. ,3	1				
15	90267-48084	.RIVET, BLIND	16				
16	33D-1466G-10	.BODY, SILENCER	1				
17	2S2-1469A-10	.FIBER	1				
18	2S2-1469E-00	.FIBER	1				
19	2S2-1469F-00	.FIBER	1				
20	8GL-14714-00	.GASKET, MUFFLER	1				
21	90119-08133	BOLT, WITH WASHER	2				
22	8GL-14789-00	BAND, SILENCER	1				
23	95024-08025	BOLT, FLG.(SMALL HEAD)	1				

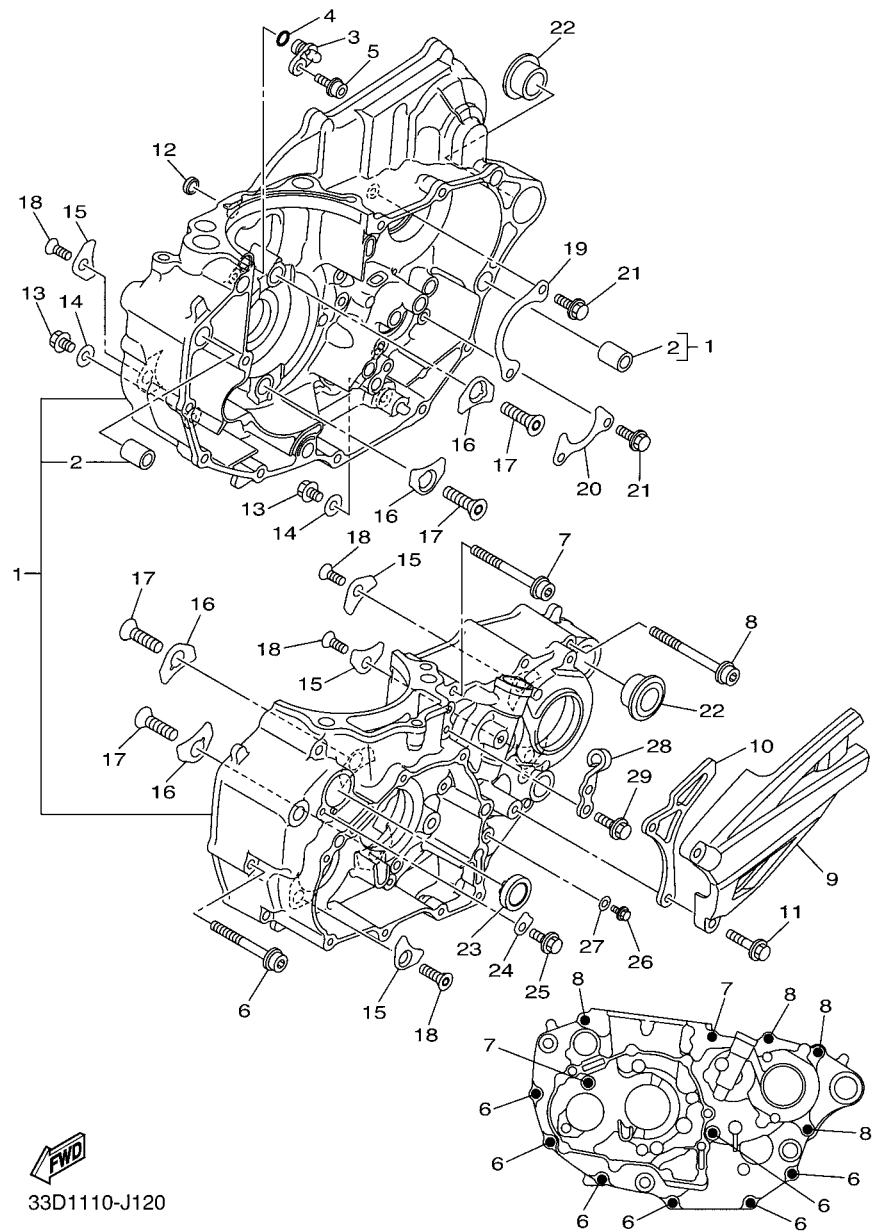

33D1110-J120

FIG. 12 CRANKCASE

REF. NO.	PART NO.	DESCRIPTION	33DD				REMARKS
1	33D-15100-09	CRANKCASE ASSY	1				
2	99530-14016	.PIN, DOWEL	2				
3	17D-15155-00	NOZZLE 3	1				
4	93210-07001	O-RING	1				
5	90110-05062	BOLT, HEXAGON SOCKET HEAD	1				
6	90110-06362	BOLT, HEXAGON SOCKET HEAD	7				
7	90110-06363	BOLT, HEXAGON SOCKET HEAD	2				
8	90110-06364	BOLT, HEXAGON SOCKET HEAD	4				
9	33D-15421-00	COVER, CRANKCASE 2	1				
10	2S2-17466-00	GUIDE, CHAIN	1				
11	90105-06189	BOLT, FLANGE	2				
12	90430-08002	GASKET	1				
13	95822-08016	BOLT, FLANGE	2				
14	90430-08119	GASKET	2				
15	4JT-15381-01	PLATE, BEARING COVER	4				
16	18P-15383-00	PLATE, BEARING COVER	4				
17	90151-08003	SCREW, COUNTERSUNK	4				
18	90149-06074	SCREW	4				
19	2S2-15388-00	PLATE, BEARING COVER	1				
20	33D-18562-00	PLATE, STOPPER 2	1				
21	90105-06081	BOLT, FLANGE	4				
22	90387-17015	COLLAR	2				
23	3Y1-15361-00	GAUGE, LEVEL	1				
24	5XC-15118-00	HOLDER	1				
25	95022-06012	BOLT, FLANGE	1				
26	95022-06012	BOLT, FLANGE	1				
27	90430-06014	GASKET	1				

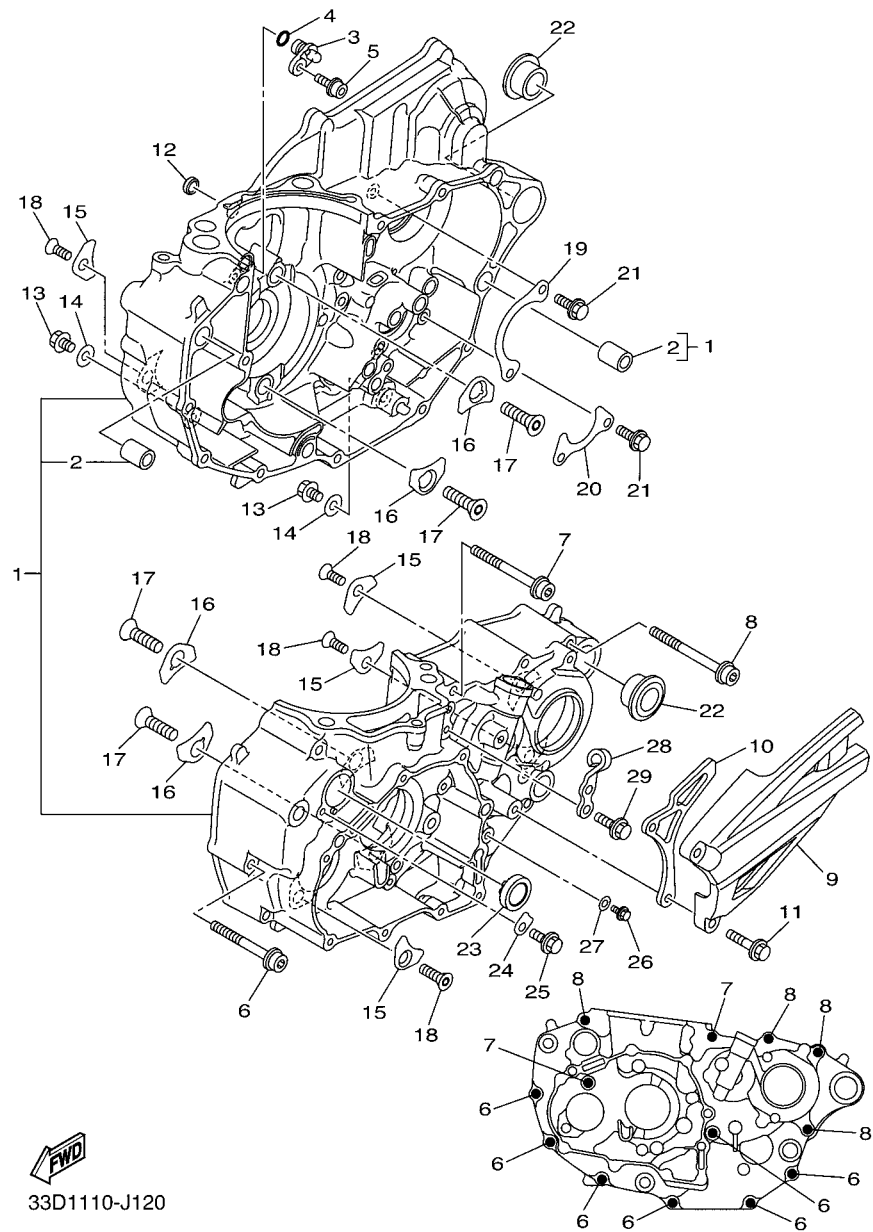
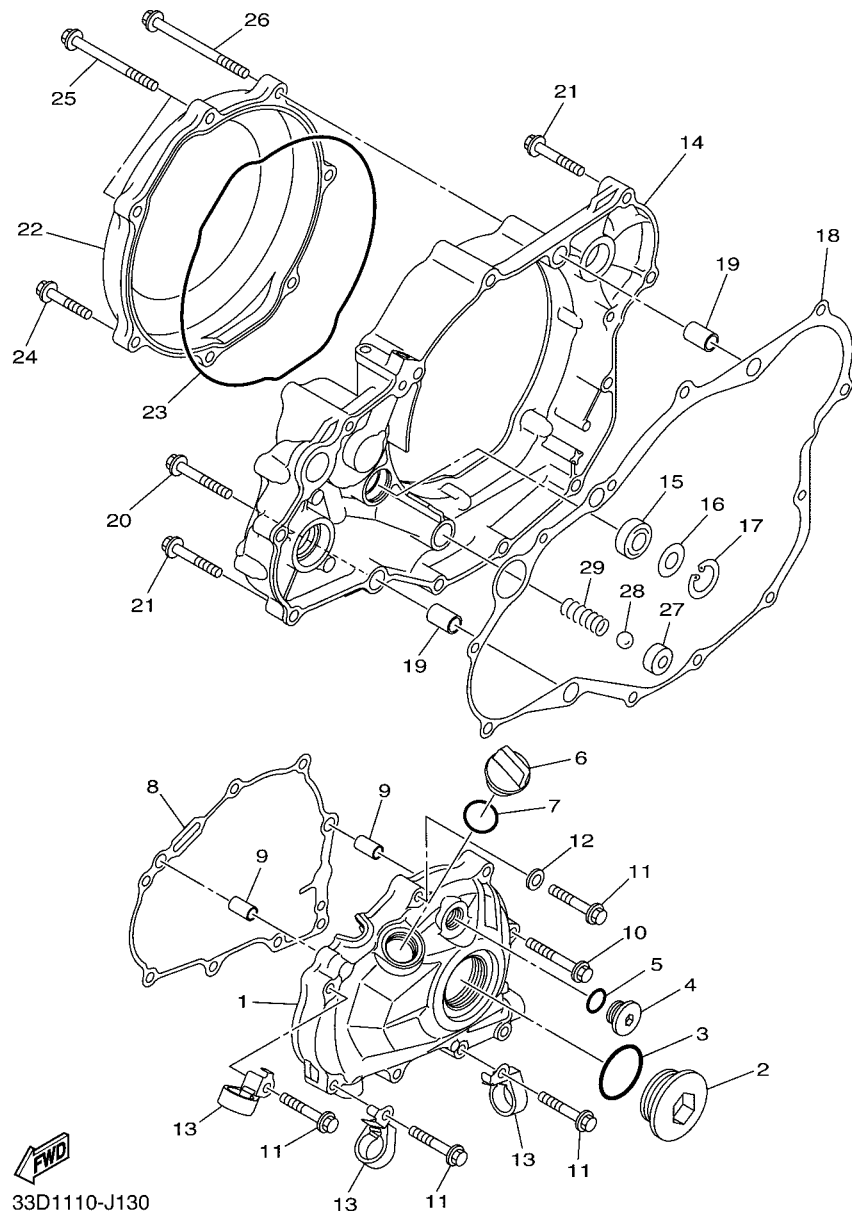

FIG. 12 CRANKCASE

REF. NO.	PART NO.	DESCRIPTION	33DD				REMARKS
28	33D-15441-10	HOLDER, CLUTCH CABLE	1				
29	90105-06099	BOLT, FLANGE	2				
<hr style="border-top: 1px dashed black;"/>							
<hr style="border-top: 1px dashed black;"/>							
<hr style="border-top: 1px dashed black;"/>							
<hr style="border-top: 1px dashed black;"/>							
<hr style="border-top: 1px dashed black;"/>							
<hr style="border-top: 1px dashed black;"/>							
<hr style="border-top: 1px dashed black;"/>							
<hr style="border-top: 1px dashed black;"/>							
<hr style="border-top: 1px dashed black;"/>							
<hr style="border-top: 1px dashed black;"/>							



33D1110-J130

FIG. 13 CRANKCASE COVER 1

REF. NO.	PART NO.	DESCRIPTION	33DD				REMARKS
1	33D-15411-00	COVER, CRANKCASE 1	1				
2	90340-36002	PLUG, STRAIGHT SCREW	1				
3	93210-357A3	O-RING	1				
4	90340-14011	PLUG, STRAIGHT SCREW	1				
5	93210-14369	O-RING	1				
6	3Y1-15363-10	PLUG, OIL	1				
7	93210-19123	O-RING	1				
8	33D-15451-00	GASKET, CRANKCASE COVER 1	1				
9	99530-08016	PIN, DOWEL	2				
10	95022-06040	BOLT, FLANGE	1				
11	95022-06030	BOLT, FLANGE	7				
12	90430-06014	GASKET	1				
13	2S2-15378-00	HOLDER	3				
14	33D-15431-00	COVER, CRANKCASE 3	1				
15	93101-14164	OIL SEAL	1				
16	90201-15701	WASHER, PLATE (T=1.0)	1				
17	99009-22500	CIRCLIP	1				
18	33D-15462-00	GASKET, CRANKCASE COVER 3	1				
19	91812-16001	PIN, DOWEL	2				
20	95022-06040	BOLT, FLANGE	1				
21	95022-06030	BOLT, FLANGE	8				
22	33D-15415-10	COVER, GENERATOR	1				
23	33D-15453-00	GASKET	1				
24	95022-06025	BOLT, FLANGE	4				
25	95022-06070	BOLT, FLANGE	2				
26	95022-06080	BOLT, FLANGE	1				
27	583-13113-00	SEAT, CHECK BALL	1				

FIG. 13 CRANKCASE COVER 1

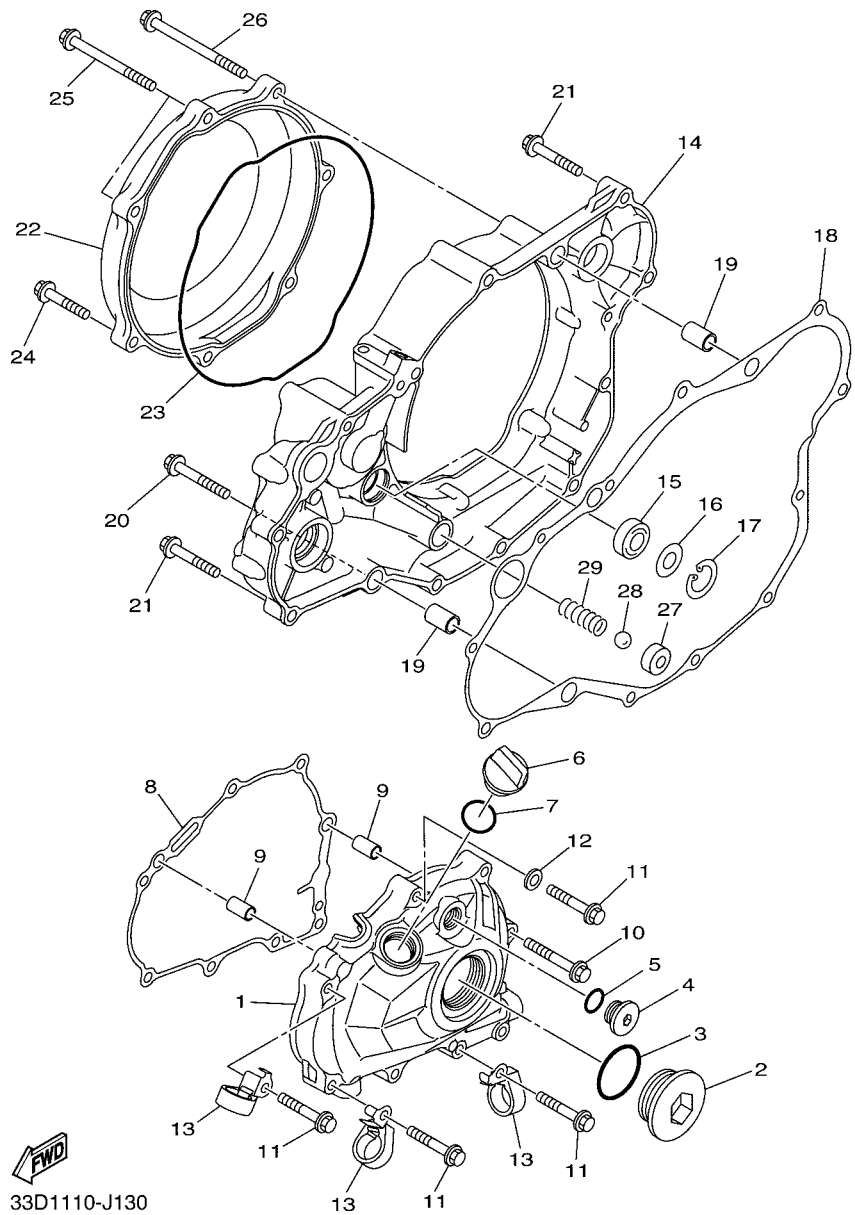

REF. NO.	PART NO.	DESCRIPTION	33DD				REMARKS
28	93503-08007	BALL	1				
29	90501-043E0	SPRING, COMPRESSION	1				

FIG. 14 STARTER

REF. NO.	PART NO.	DESCRIPTION	33DD				REMARKS
1	2S2-15601-00	KICK SHAFT ASSY	1				
2	90201-20685	.WASHER, PLATE (T=0.5)	1				
3	93410-20038	.CIRCLIP	1				
4	2S2-15671-00	.WHEEL, RATCHET	1				
5	90501-160A2	.SPRING, COMPRESSION	1				
6	90201-167P7	.WASHER, PLATE	1				
7	99009-16400	.CIRCLIP	1				
8	5GR-15664-00	.GUIDE, SPRING	1				
9	90508-305B0	.SPRING, TORSION	1				
10	90201-162H4	WASHER, PLATE	1				
11	3Y6-15674-00	GUIDE, RATCHET WHEEL	1				
12	2NX-15668-00	STOPPER	1				
13	90101-06044	BOLT	2				
14	93102-20108	OIL SEAL	1				
15	5TA-15651-00	GEAR, KICK IDLE	1				
16	90201-20685	WASHER, PLATE (T=0.5)	1				
17	99009-20400	CIRCLIP	1				
18	33D-15620-01	KICK CRANK ASSY	1				
19	33D-15621-01	.BOSS, KICK CRANK	1				
20	90501-147A5	.SPRING, COMPRESSION	1				
21	93507-32009	.BALL	1				
22	90151-06045	.SCREW, COUNTERSUNK	1				
23	93210-17570	.O-RING	1				
24	90110-08087	BOLT, HEXAGON SOCKET HEAD	1				
25	90201-08047	WASHER, PLATE	1				

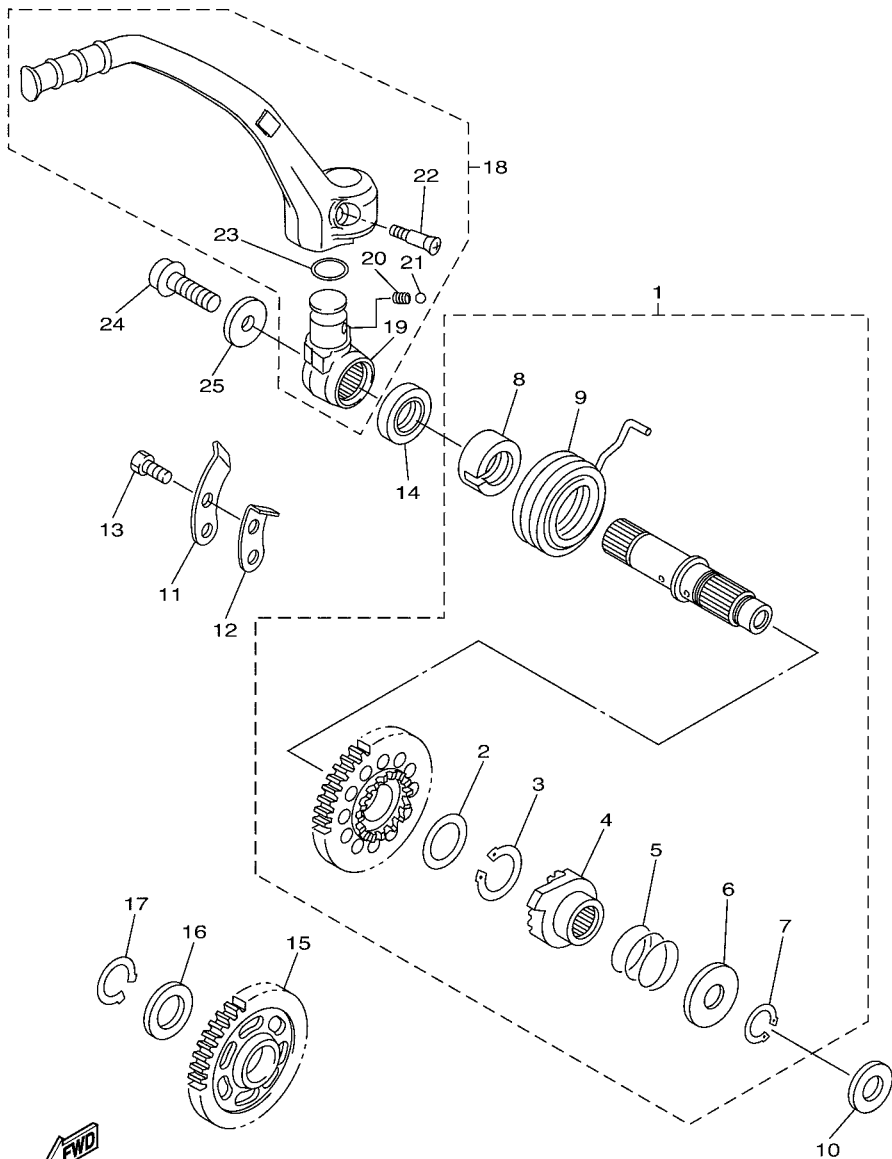

FWD

33D1110-J140

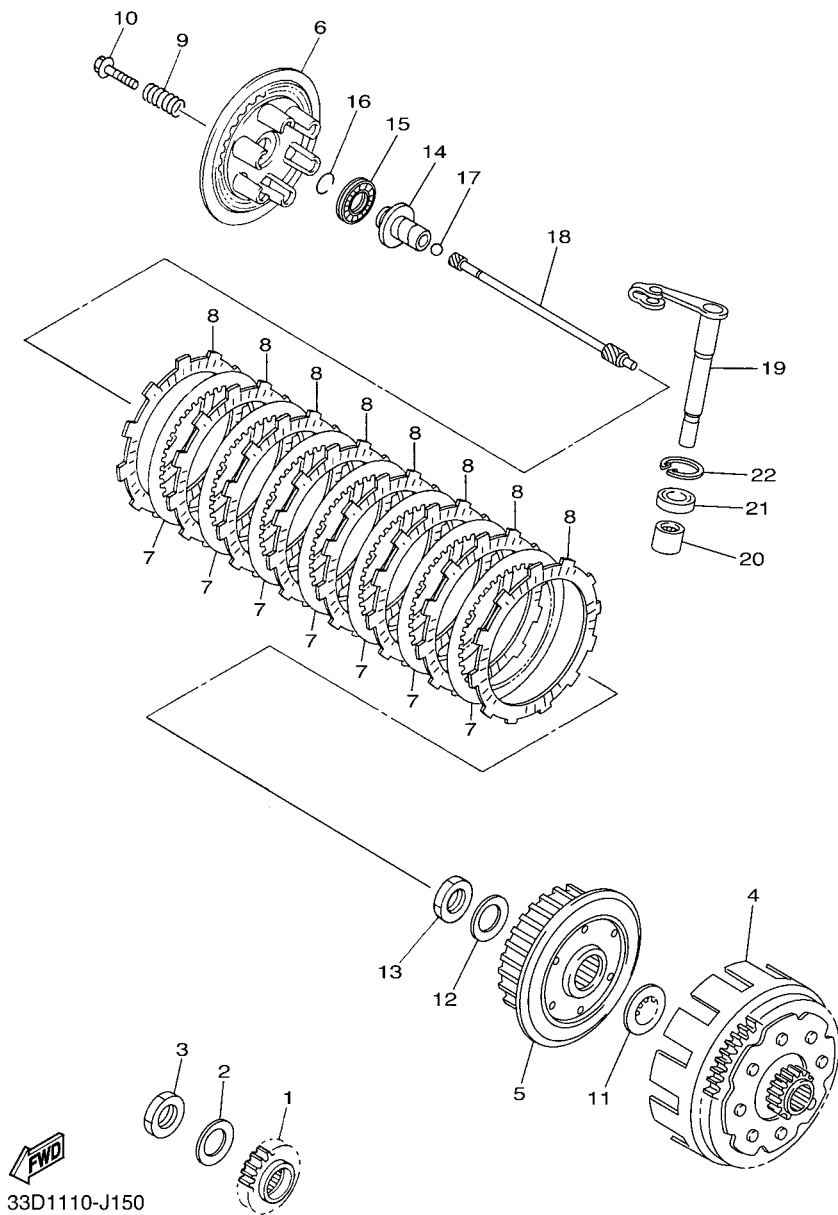

FIG. 15 CLUTCH

REF. NO.	PART NO.	DESCRIPTION	33DD				REMARKS
1	2S2-16111-60	GEAR, PRIMARY DRIVE	1				
2	90208-20008	WASHER, CONICAL SPRING	1				
3	90170-20255	NUT	1				
4	5XD-16150-60	PRIMARY DRIVEN GEAR COMP.	1				
5	5TA-16371-10	BOSS, CLUTCH	1				
6	2S2-16351-00	PLATE, PRESSED 1	1				
7	4B1-16324-00	PLATE, CLUTCH 1	7				
8	5TA-16321-00	PLATE, FRICTION	8				
9	90501-230E4	SPRING, COMPRESSION	6				
10	90159-06010	SCREW, WITH WASHER	6				
11	5XD-16154-00	PLATE, THRUST 1	1				
12	90208-20008	WASHER, CONICAL SPRING	1				
13	90170-20255	NUT	1				
14	33D-16356-00	ROD, PUSH 1	1				
15	93340-21209	BEARING	1				
16	93440-10085	CIRCLIP	1				
17	93511-32027	BALL	1				
18	2S2-16357-00	ROD, PUSH 2	1				
19	33D-16381-10	PUSH LEVER COMP.	1				
20	93317-11287	BEARING	1				
21	93102-12224	OIL SEAL	1				
22	99009-20500	CIRCLIP	1				

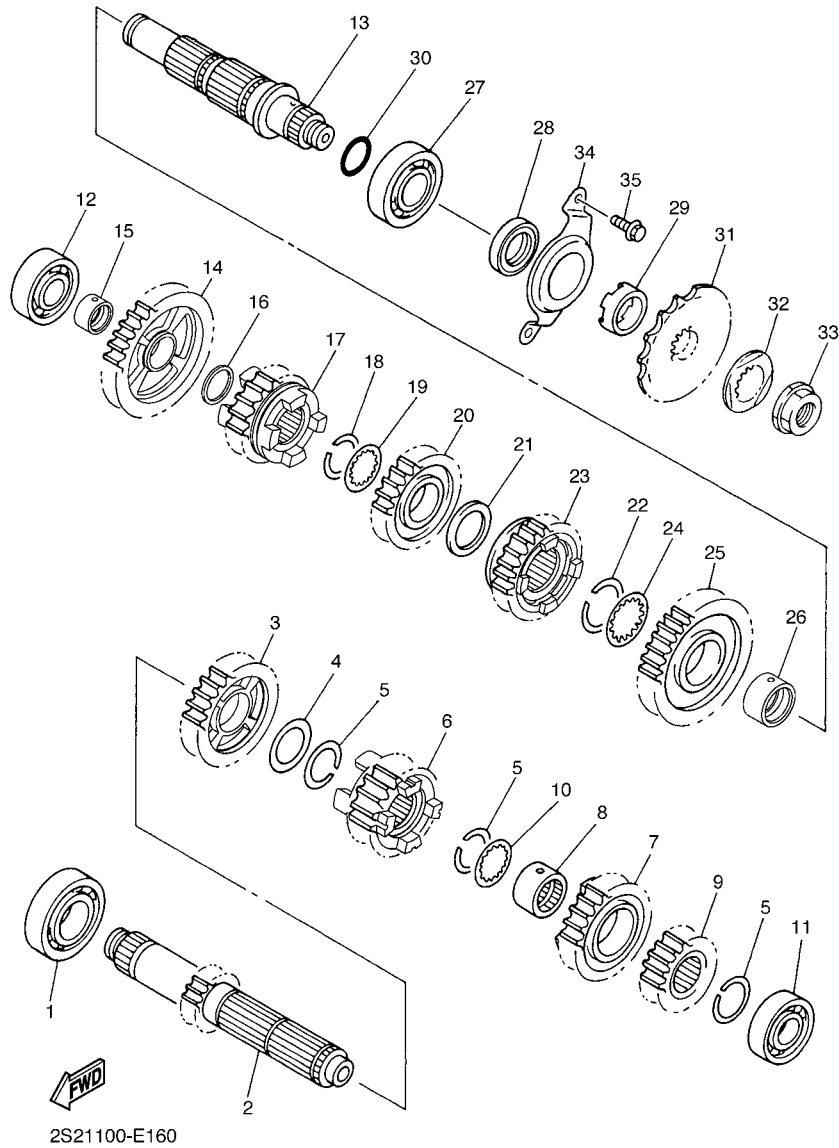

FIG. 16 TRANSMISSION

REF. NO.	PART NO.	DESCRIPTION	33DD				REMARKS
1	93306-20532	BEARING	1				
2	2S2-17411-00	AXLE,MAIN(14T)	1				
3	2S2-17151-00	GEAR, 5TH PINION(21T)	1				
4	90201-253K0	WASHER, PLATE (T=1.0)	1				
5	93440-25084	CIRCLIP	3				
6	33D-17131-00	GEAR, 3RD PINION (18T)	1				
7	2S2-17141-00	GEAR, 4TH PINION (22T)	1				
8	90387-21005	COLLAR	1				
9	2S2-17121-00	GEAR, 2ND PINION(15T)	1				
10	90209-21332	WASHER	1				
11	93306-00447	BEARING	1				
12	93306-00426	BEARING	1				
13	33D-17402-00	DRIVE AXLE ASSY	1				
14	2S2-17211-00	GEAR, 1ST WHEEL(27T)	1				
15	90387-20028	COLLAR	1				
16	90201-203E7	WASHER, PLATE	1				
17	33D-17251-00	GEAR, 5TH WHEEL (20T)	1				
18	93440-25084	CIRCLIP	1				
19	90209-22008	WASHER	1				
20	2S2-17231-00	GEAR, 3RD WHEEL(23T)	1				
21	90201-253K0	WASHER, PLATE (T=1.0)	1				
22	93440-28062	CIRCLIP	1				
23	2S2-17241-00	GEAR, 4TH WHEEL(24T)	1				
24	90209-26348	WASHER	1				
25	2S2-17221-00	GEAR, 2ND WHEEL(23T)	1				
26	90387-28012	COLLAR	1				
27	93306-205A5	BEARING	1				

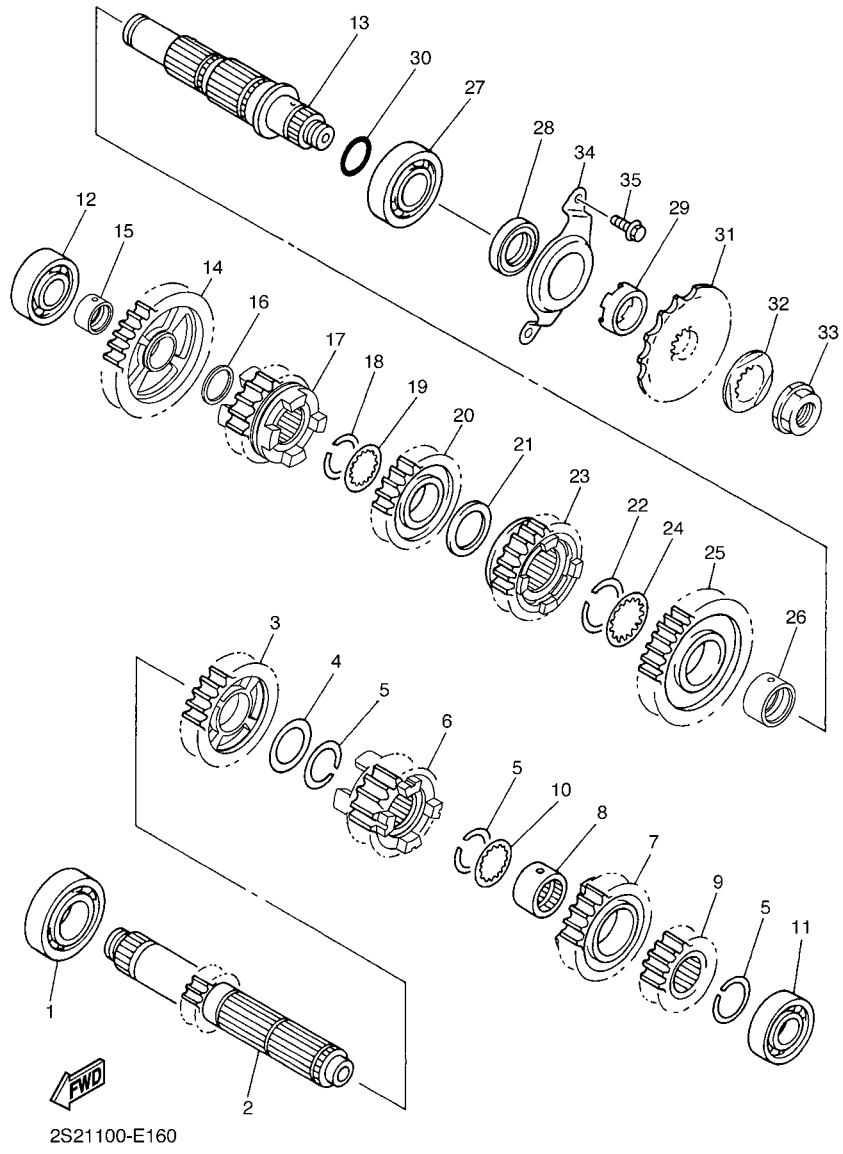
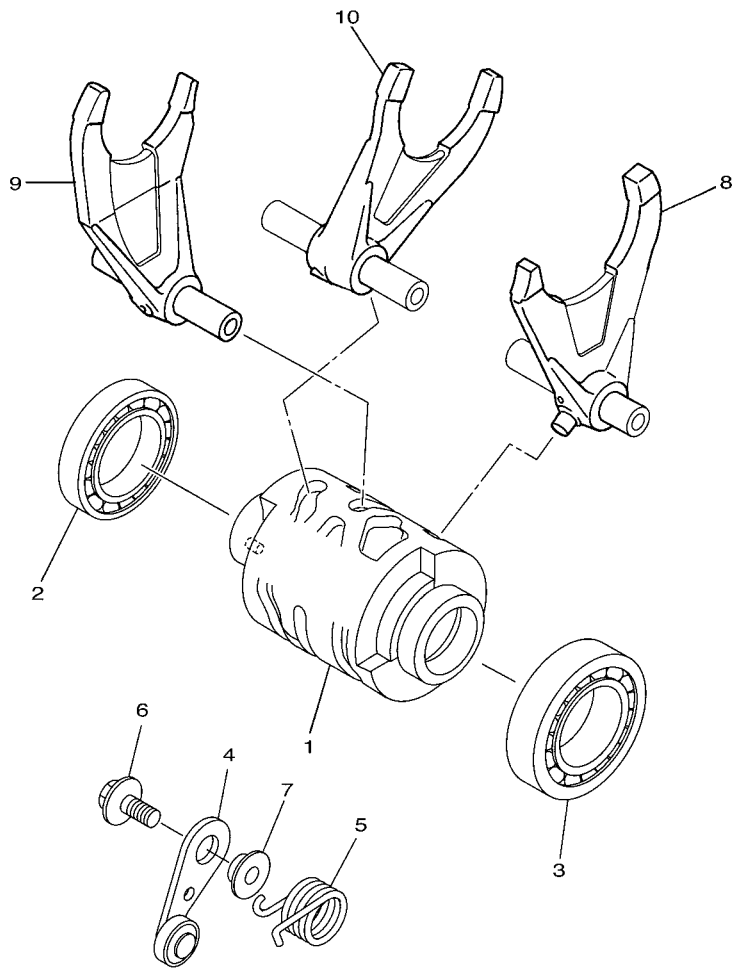

FIG. 16 TRANSMISSION

REF. NO.	PART NO.	DESCRIPTION	33DD				REMARKS
28	93102-32480	OIL SEAL	1				
29	90387-2513F	COLLAR	1				
30	93210-22164	O-RING	1				
31	9383E-13233	SPROCKET, DRIVE (13T)	1				
32	90215-21003	WASHER, LOCK	1				
33	90179-20001	NUT	1				
34	2S2-17471-00	PLATE, COVER	1				
35	90105-06081	BOLT, FLANGE	2				
<hr/>							
<hr/>							
<hr/>							
<hr/>							
<hr/>							
<hr/>							
<hr/>							
<hr/>							
<hr/>							



33D1110-J170

FIG. 17 SHIFT CAM & FORK

REF. NO.	PART NO.	DESCRIPTION	33DD				REMARKS
1	33D-18541-10	CAM, SHIFT	1				
2	93306-90409	BEARING	1				
3	93306-80502	BEARING	1				
4	33D-18140-00	STOPPER LEVER ASSY	1				
5	90508-26021	SPRING, TORSION	1				
6	90159-06027	SCREW, WITH WASHER	1				
7	33D-18175-00	SPACER	1				
8	33D-18501-10	FORK, SHIFT 1	1				
9	33D-18502-10	FORK, SHIFT 2	1				
10	5TG-18503-00	FORK, SHIFT 3	1				

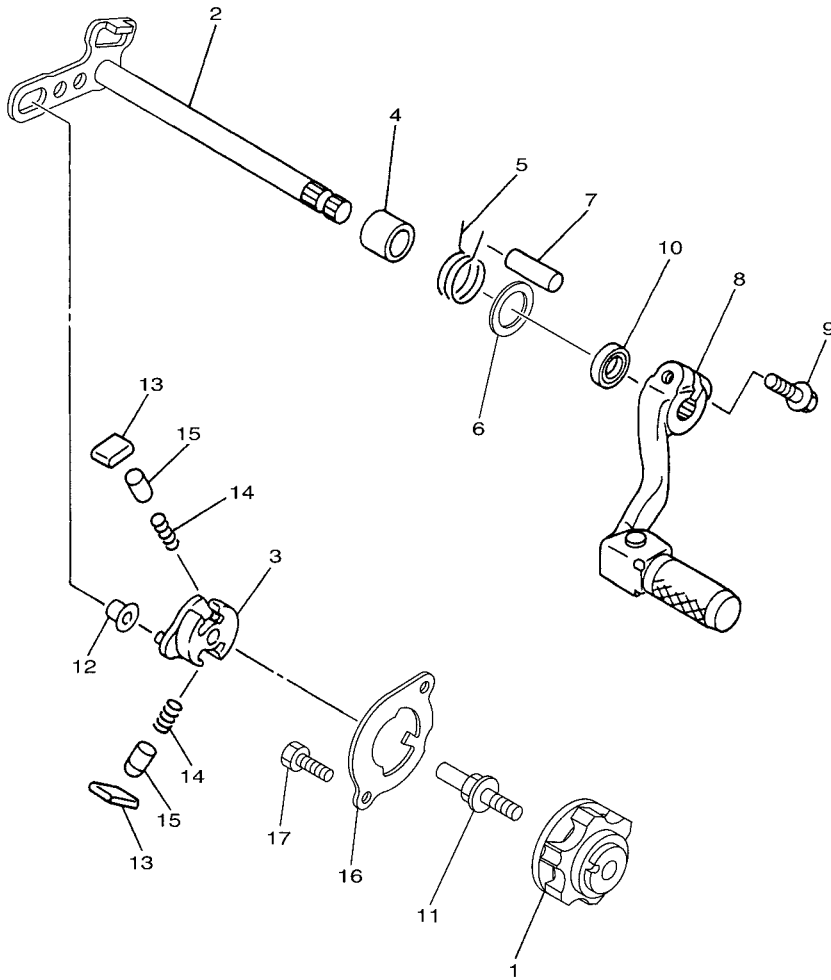

33D1110-J180

FIG. 18 SHIFT SHAFT

REF. NO.	PART NO.	DESCRIPTION	33DD				REMARKS
1	1C3-18185-00	SEGMENT	1				
2	33D-18101-00	SHIFT SHAFT ASSY	1				
3	18P-18122-00	LEVER, SHIFT 2	1				
4	90387-124F4	COLLAR	1				
5	90508-29021	SPRING, TORSION	1				
6	90201-127E1	WASHER, PLATE	1				
7	93608-33002	PIN, DOWEL	1				
8	2S2-18110-00	SHIFT PEDAL ASSY	1				
9	90105-06127	BOLT, FLANGE	1				
10	93102-12224	OIL SEAL	1				
11	3XJ-18173-10	PIN, SHIFT	1				
12	3XJ-18178-00	ROLLER, SHIFT LEVER	1				
13	3XJ-18182-00	PAWL, SHIFTER	2				
14	90501-052G5	SPRING, COMPRESSION	2				
15	3XJ-18184-00	PIN, PAWL	2				
16	5TJ-18172-00	GUIDE, SHIFT	1				
17	90101-06041	BOLT	2				

FIG. 19 FRAME

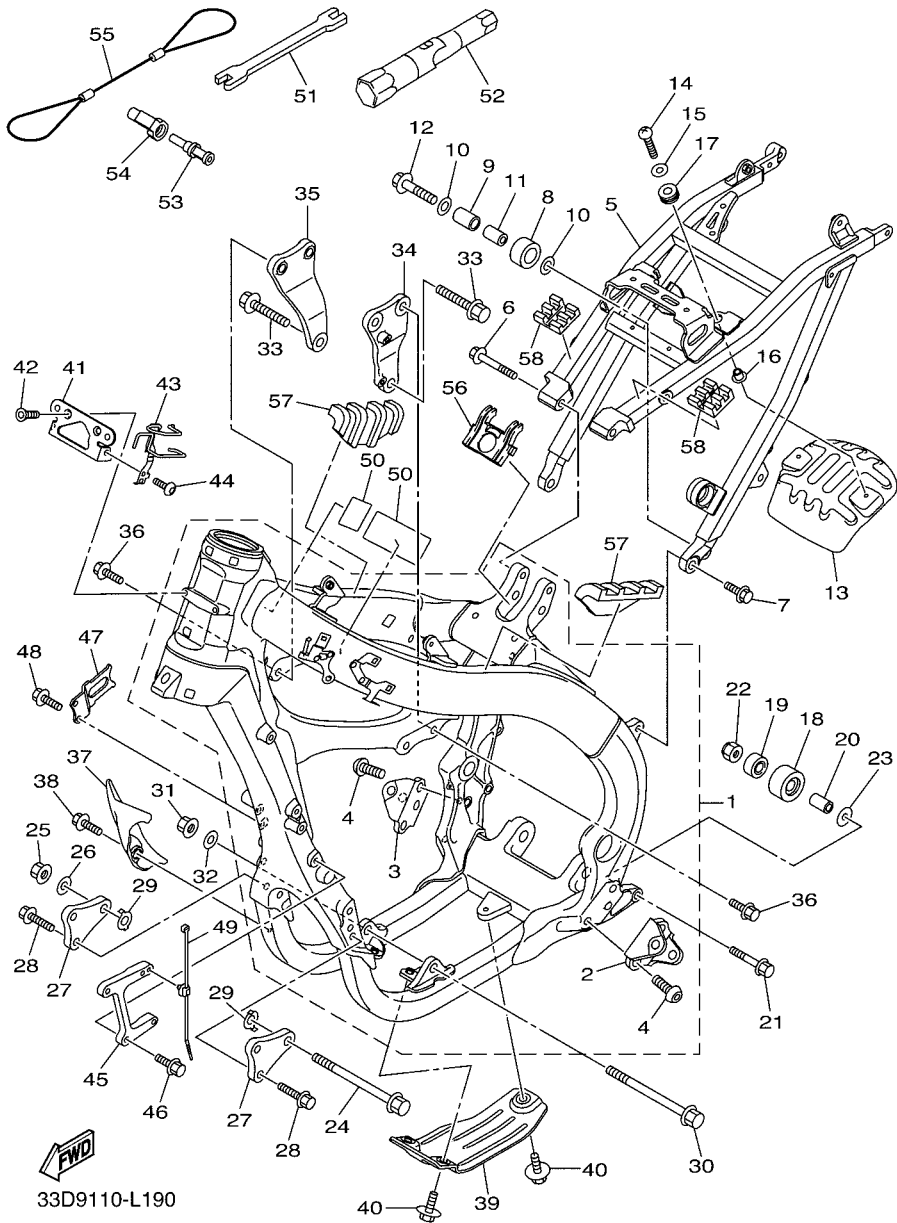

33D9110-L190

REF. NO.	PART NO.	DESCRIPTION	33DD				REMARKS
1	33D-21101-90	FRONT FRAME COMP.	1				
2	17D-21447-00	.BRACKET, FOOTREST	1				
3	17D-21448-00	.BRACKET, FOOTREST	1				
4	90149-10031	.SCREW	4				
5	33D-21190-00	REAR FRAME COMP.	1				
6	90105-08231	BOLT, FLANGE	2				
7	90105-08230	BOLT, FLANGE	2				
8	30X-22178-00	TENSIONER	1				
9	4V4-22184-00	BUSH	1				
10	90201-08045	WASHER, PLATE	2				
11	90387-08041	COLLAR	1				
12	95022-08040	BOLT, FLANGE	1				
13	33D-2117F-00	COVER	1				
14	98502-05016	SCREW, PAN HEAD	2				
15	90201-05N15	WASHER, PLATE	2				
16	90387-05003	COLLAR	2				
17	90480-12025	GROMMET	2				
18	3JD-22178-20	TENSIONER	1				
19	93300-60839	BEARING	1				
20	90387-086N4	COLLAR	1				
21	90105-08232	BOLT, FLANGE	1				
22	90185-08009	NUT, SELF-LOCKING	1				
23	90201-08043	WASHER, PLATE	1				
24	90105-10193	BOLT, FLANGE	1				
25	90179-10658	NUT	1				
26	90201-10045	WASHER, PLATE	1				
27	33D-21417-00	BRACKET, FRONT LOWER 1	2				

FIG. 19 FRAME

REF. NO.	PART NO.	DESCRIPTION	33DD				REMARKS
28	90105-08143	BOLT, FLANGE	4				
29	5XC-21456-90	PLATE, PATCH	2				
30	90105-10176	BOLT, FLANGE	1				
31	90179-10658	NUT	1				
32	90201-10045	WASHER, PLATE	1				
33	90105-10189	BOLT, FLANGE	2				
34	33D-21425-00	BRACKET, REAR UPPER 1	1				
35	33D-21426-00	BRACKET, REAR UPPER 2	1				
36	90105-08226	BOLT, FLANGE	4				
37	33D-21471-00	PROTECTOR, ENGINE	1				
38	90119-06149	BOLT, WITH WASHER	1				
39	33D-2147E-00	GUARD, ENGINE 2	1				
40	90119-06146	BOLT, WITH WASHER	3				
41	33D-2116M-00	BRACKET 10	1				
42	90151-06032	SCREW, COUNTERSUNK	2				
43	33D-21163-00	HOLDER, CLUTCH CABLE	1				
44	92012-05010	BOLT, BUTTON HEAD	1				
45	33D-2194U-00	STAY, IGNITION COIL	1				
46	90105-06170	BOLT, FLANGE	2				
47	33D-2116J-00	BRACKET 7	1				
48	95022-06010	BOLT, FLANGE	2				
49	90464-31002	CLAMP	1				
50	33D-21268-00	SEAL	2				
51	5ET-28166-10	WRENCH, HEXAGON	1				
52	5TA-2814F-00	BOX, SPARK PLUG	1				
53	18P-2467E-00	CAP	1				
54	18P-2464V-00	CASE, CAP	1				

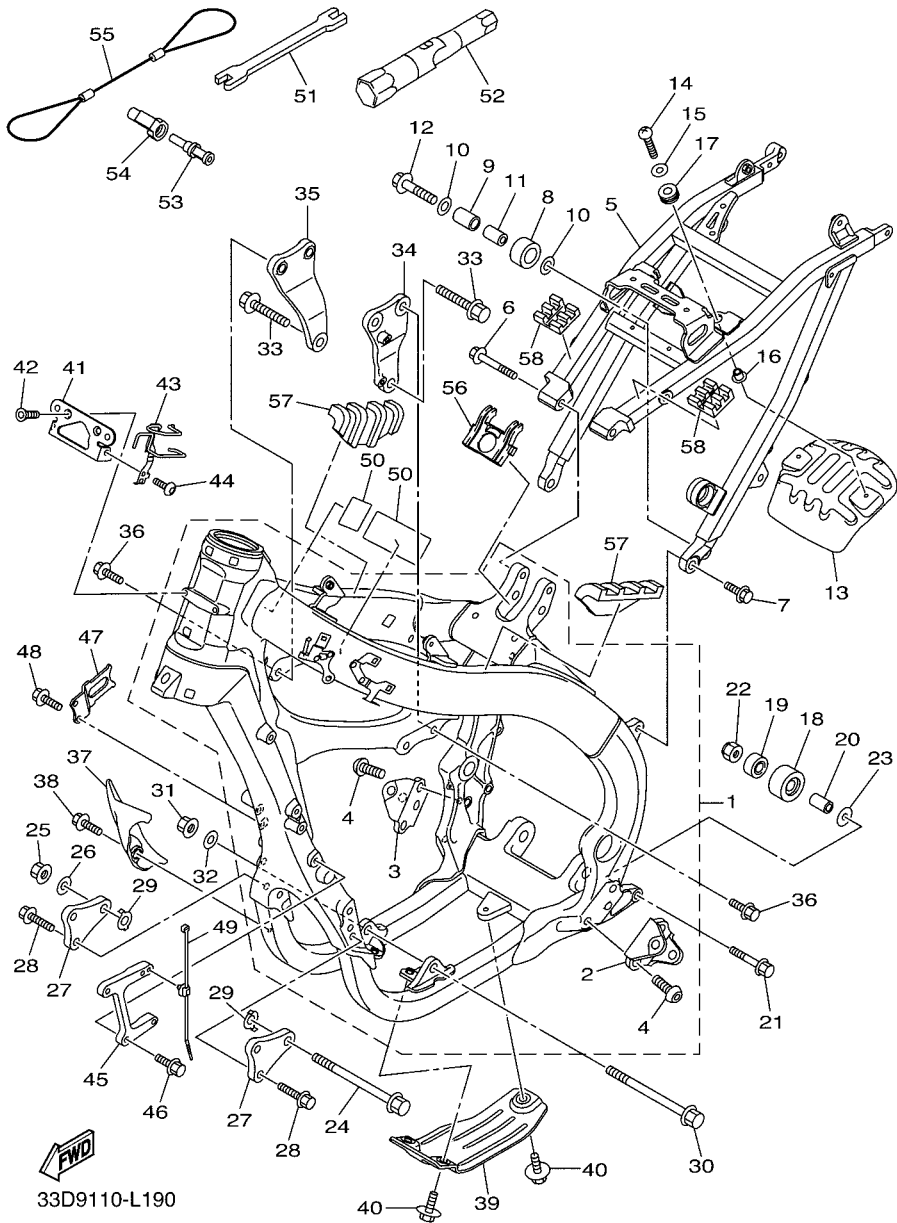

33D9110-L190

FIG. 19 FRAME

REF. NO.	PART NO.	DESCRIPTION	33DD				REMARKS
55	33D-2814A-00	WIRE, HOOK	1				
56	33D-24181-00	DAMPER, LOCATING 1	1				
57	33D-24182-00	DAMPER, LOCATING 2	2				
58	33D-24183-00	DAMPER, LOCATING 3	2				

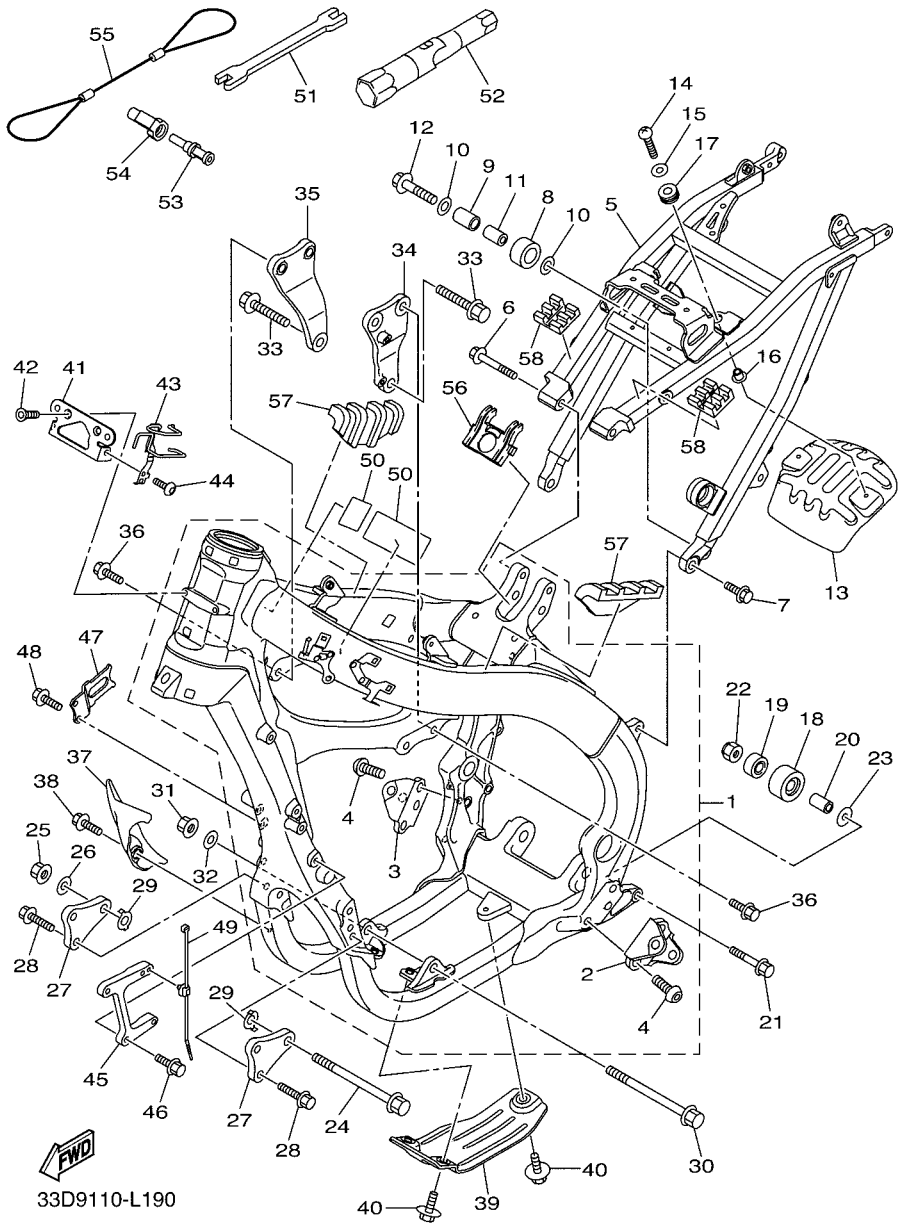

33D9110-L190

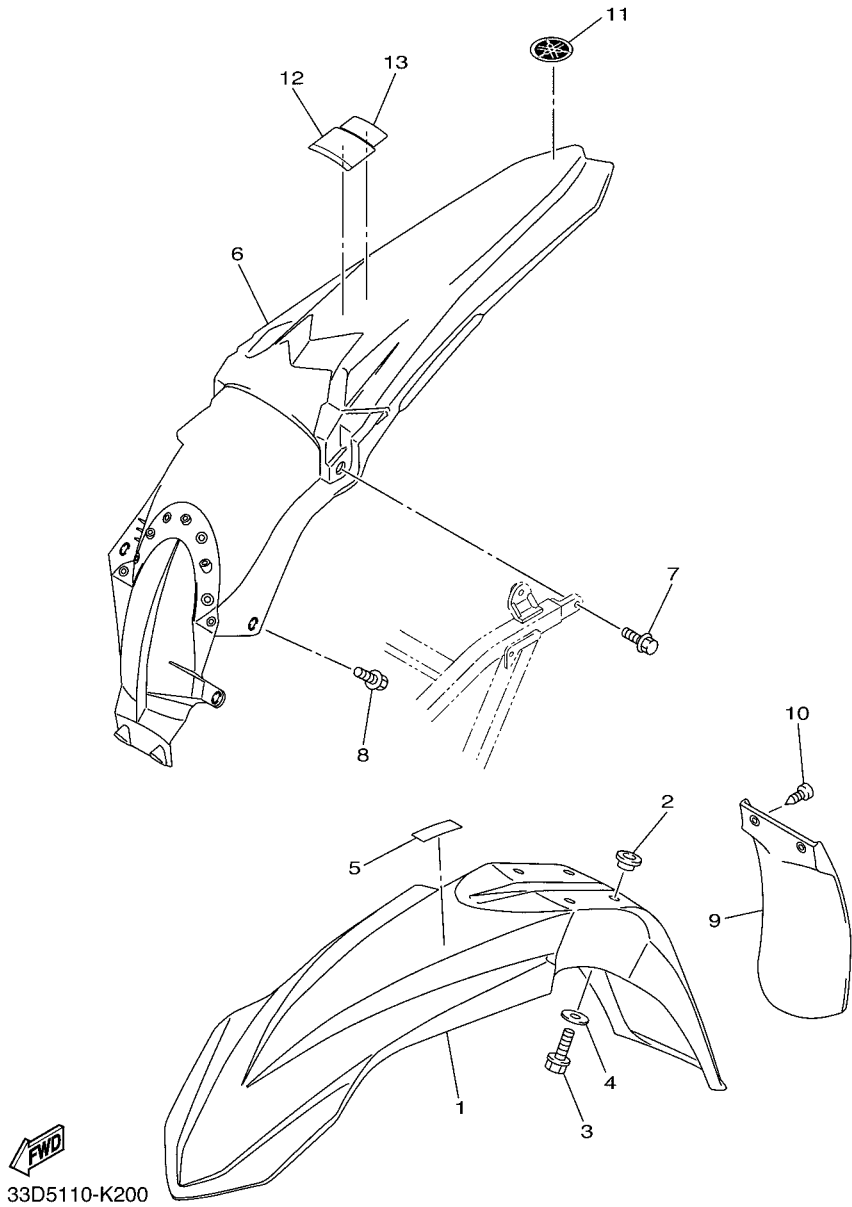
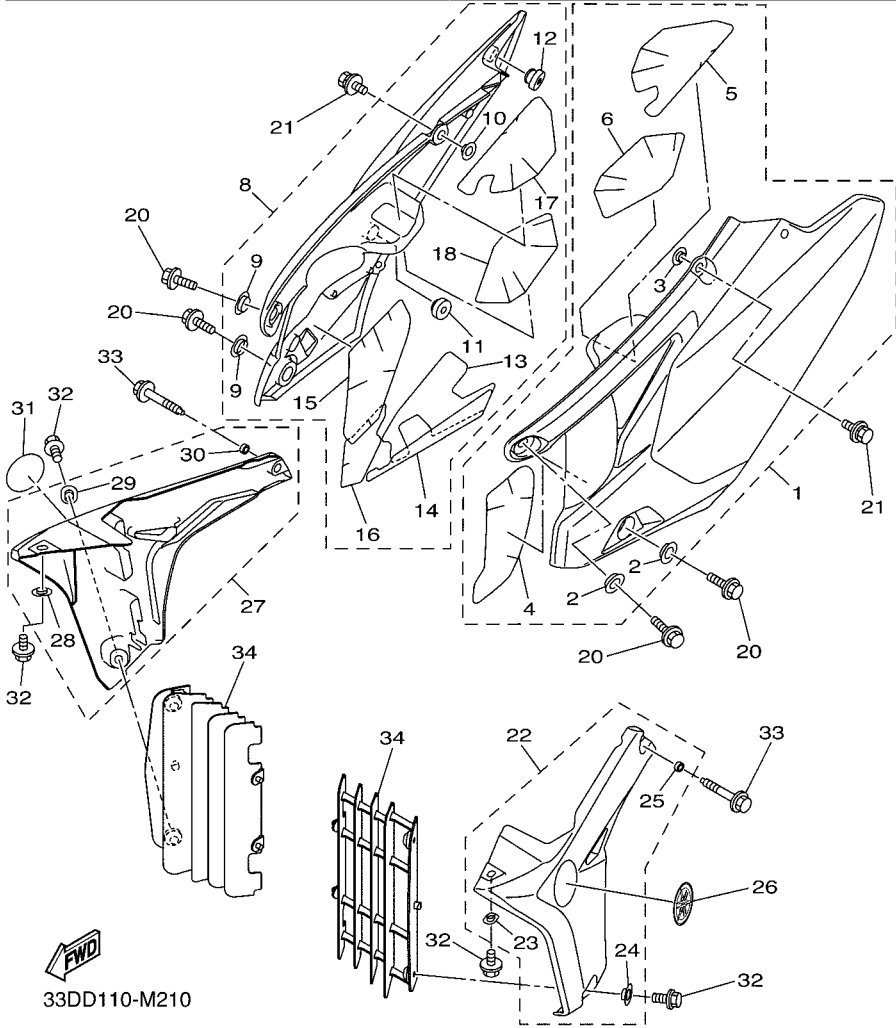
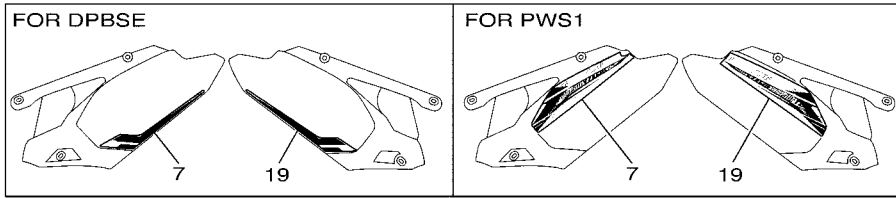

FIG. 20 FENDER

REF. NO.	PART NO.	DESCRIPTION	33DD			REMARKS
1	17D-21511-50	FENDER, FRONT	1			UR FOR DPBSE
	17D-21511-60	FENDER, FRONT	1			UR FOR PWS1
2	90387-06259	COLLAR	4			
3	90105-06127	BOLT, FLANGE	4			
4	90201-06108	WASHER, PLATE	4			
5	3FB-2415E-02	LABEL, CAUTION	1			
6	33D-21610-10	REAR FENDER COMP.	1			
7	90105-06100	BOLT, FLANGE	2			
8	90105-06170	BOLT, FLANGE	3			
9	33D-21642-00	GUARD, FLAP	1			
10	97702-60016	SCREW, TAPPING	2			
11	3C5-2411B-20	EMBLEM	1			
12	5PA-2118K-00	LABEL, CAUTION	1			
13	17D-2812P-00	PLATE, COMPETITION USA	1			

FIG. 21 SIDE COVER



REF. NO.	PART NO.	DESCRIPTION	33DD			REMARKS
1	33D-21710-01	SIDE COVER ASSY 1	1			
2	17D-21749-00	.COLLAR	2			
3	5BE-21749-00	.COLLAR	1			
4	33D-2172S-00	.INSULATOR 3	1			
5	33D-2172P-00	.SEAT	1			
6	33D-2174P-00	.SEAT 3	1			
7	33D-2174G-40	GRAPHIC 3	1			UR FOR DPBSE
	33D-2174G-50	GRAPHIC 3	1			UR FOR PWS1
8	33D-21720-01	SIDE COVER ASSY 2	1			
9	17D-21749-00	.COLLAR	2			
10	5BE-21749-00	.COLLAR	1			
11	5XC-21719-90	.GROMMET	1			
12	33D-21719-00	.GROMMET	1			
13	33D-2174A-00	.INSULATOR, SIDE COVER	1			
14	33D-2174T-00	.INSULATOR, SIDE COVER 2	1			
15	33D-2173S-00	.INSULATOR 4	1			
16	33D-2174S-00	.INSULATOR 5	1			
17	33D-2173P-00	.SEAT 2	1			
18	33D-2175P-00	.SEAT 4	1			
19	33D-2174H-40	GRAPHIC 4	1			UR FOR DPBSE
	33D-2174H-50	GRAPHIC 4	1			UR FOR PWS1
20	90105-06170	BOLT, FLANGE	4			
21	90119-08095	BOLT, WITH WASHER	2			
22	33D-21730-51	SIDE COVER ASSY 3	1			UR FOR DPBSE
	33D-21730-01	SIDE COVER ASSY 3	1			UR FOR PWS1
23	5PA-21748-00	.COLLAR	1			
24	17D-21749-00	.COLLAR	1			

FIG. 21 SIDE COVER

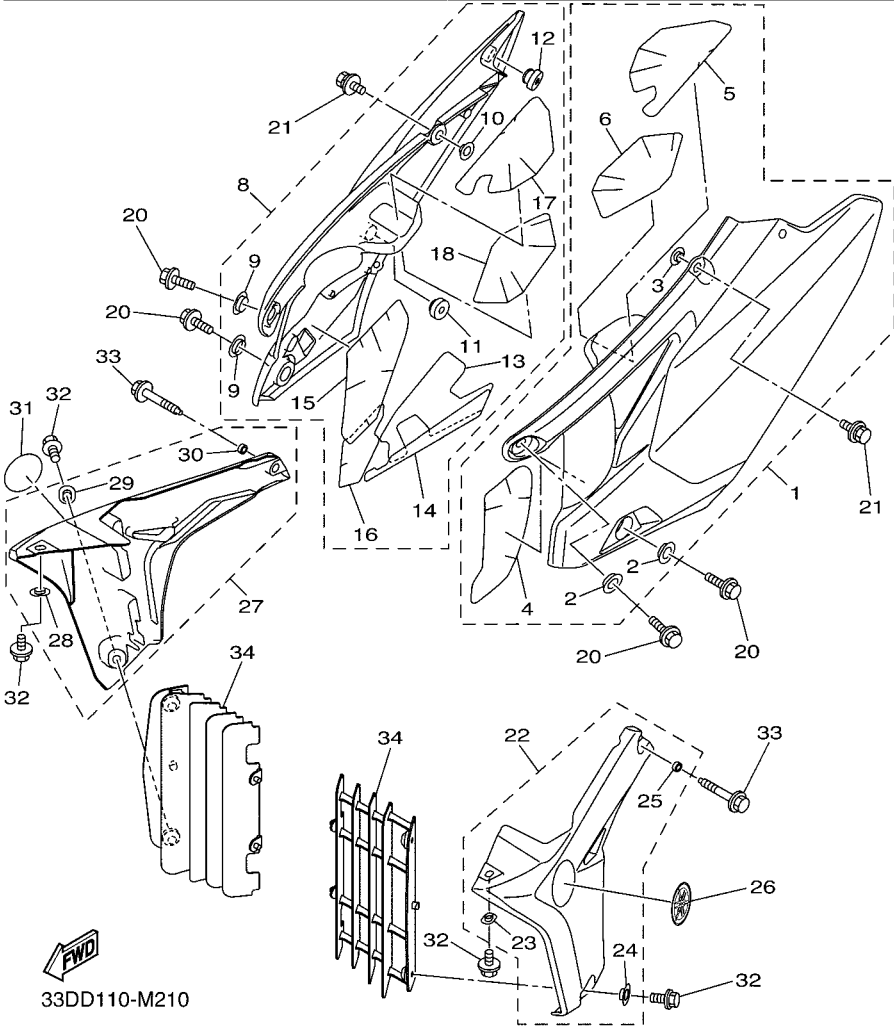
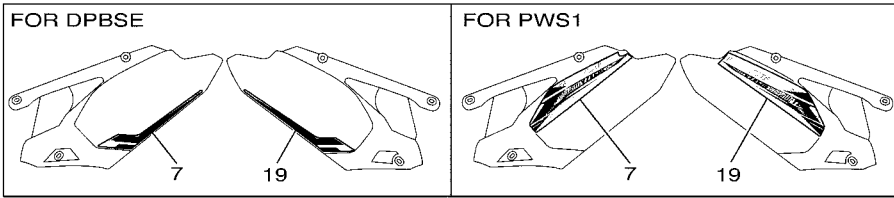

33DD110-M210

REF. NO.	PART NO.	DESCRIPTION	33DD				REMARKS
25	90387-06133	.COLLAR	1				
26	5PW-2413B-00	EMBLEM	1				
27	33D-21740-51	SIDE COVER ASSY 4	1				UR FOR DPBSE
	33D-21740-01	SIDE COVER ASSY 4	1				UR FOR PWS1
28	5PA-21748-00	.COLLAR	1				
29	17D-21749-00	.COLLAR	1				
30	90387-06133	.COLLAR	1				
31	5PW-2413B-00	EMBLEM	1				
32	90105-06064	BOLT, FLANGE	4				
33	90105-06179	BOLT, FLANGE	2				
34	33D-2172A-00	PANEL 1	2				

FIG. 22 REAR ARM

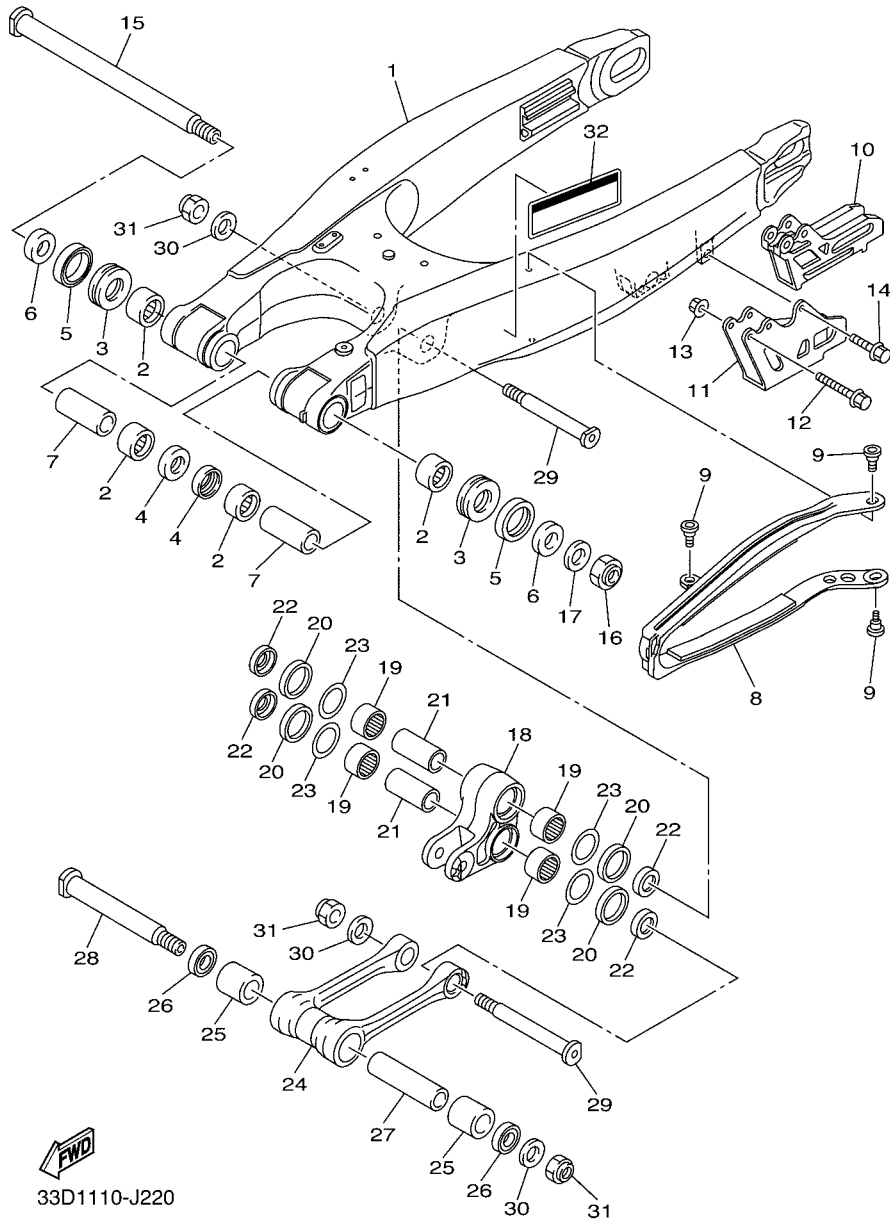

33D1110-J220

REF. NO.	PART NO.	DESCRIPTION	33DD				REMARKS
1	33D-22110-00	REAR ARM COMP.	1				
2	93317-22262	BEARING	4				
3	93342-22217	BEARING	2				
4	93106-22002	OIL SEAL	2				
5	93109-28043	OIL SEAL	2				
6	90387-17016	COLLAR	2				
7	90387-1714S	COLLAR	2				
8	34P-22151-01	SEAL, GUARD	1				
9	1C3-22969-90	SCREW, 1	3				
10	2S2-22199-70	SUPPORT, CHAIN	1				
11	2S2-22128-70	COVER, THRUST 1	1				
12	90105-06104	BOLT, FLANGE	2				
13	95702-06500	NUT, FLANGE	2				
14	90105-06105	BOLT, FLANGE	1				
15	33D-22141-00	SHAFT, PIVOT	1				
16	90185-16002	NUT, SELF-LOCKING	1				
17	90201-16018	WASHER, PLATE	1				
18	17D-2217A-00	ARM, RELAY	1				
19	93315-32166	BEARING	4				
20	93109-25001	OIL SEAL	4				
21	90387-16026	COLLAR	2				
22	90209-16011	WASHER	4				
23	90201-21014	WASHER, PLATE	4				
24	33D-2217F-00	ROD, CONNECTING 1	1				
25	93315-32166	BEARING	2				
26	93109-21001	OIL SEAL	2				
27	90387-14016	COLLAR	1				

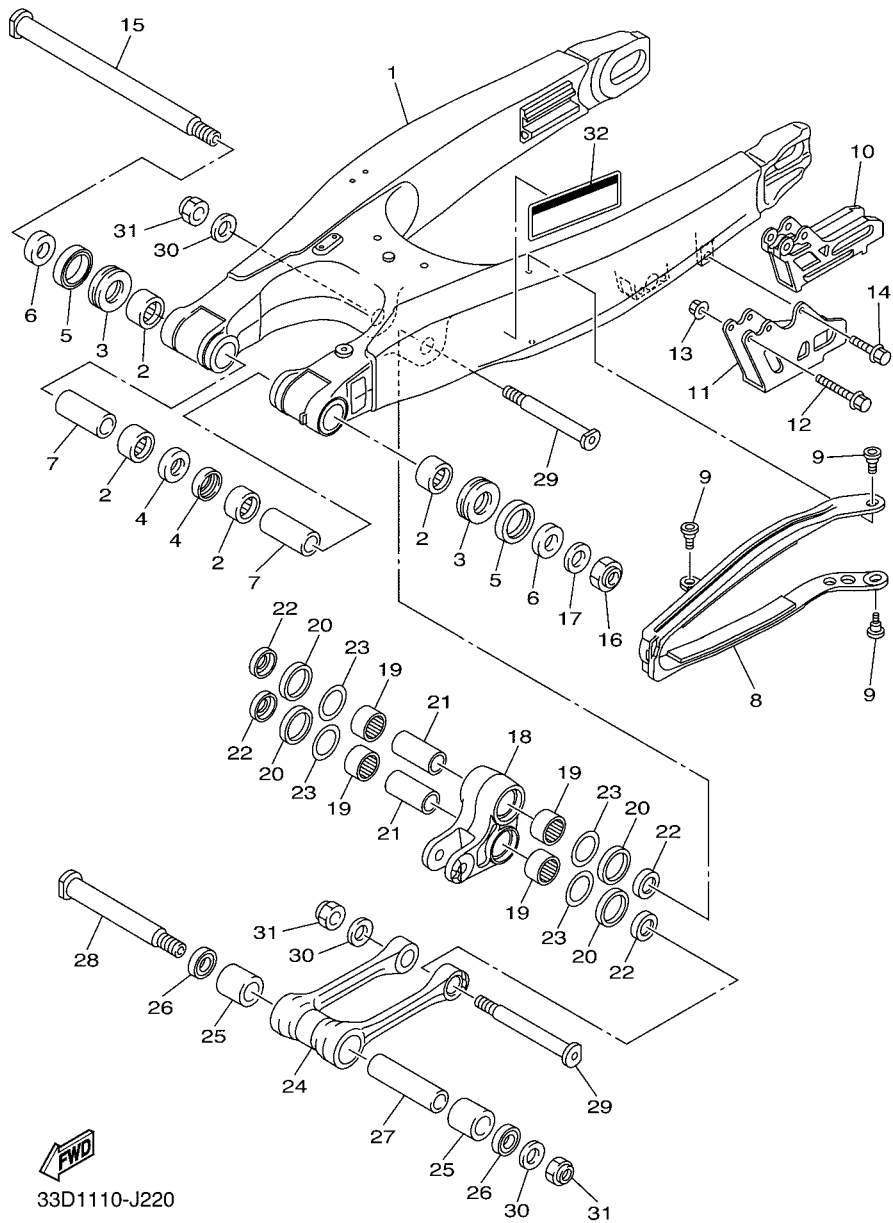

33D1110-J220

FIG. 22 REAR ARM

REF. NO.	PART NO.	DESCRIPTION	33DD					REMARKS
28	5XC-22121-91	SHAFT 1	1					
29	34P-22122-00	SHAFT 2	2					
30	90201-14020	WASHER, PLATE	3					
31	90185-14010	NUT, SELF-LOCKING	3					
32	3RV-21668-A0	LABEL, TIRE	1					

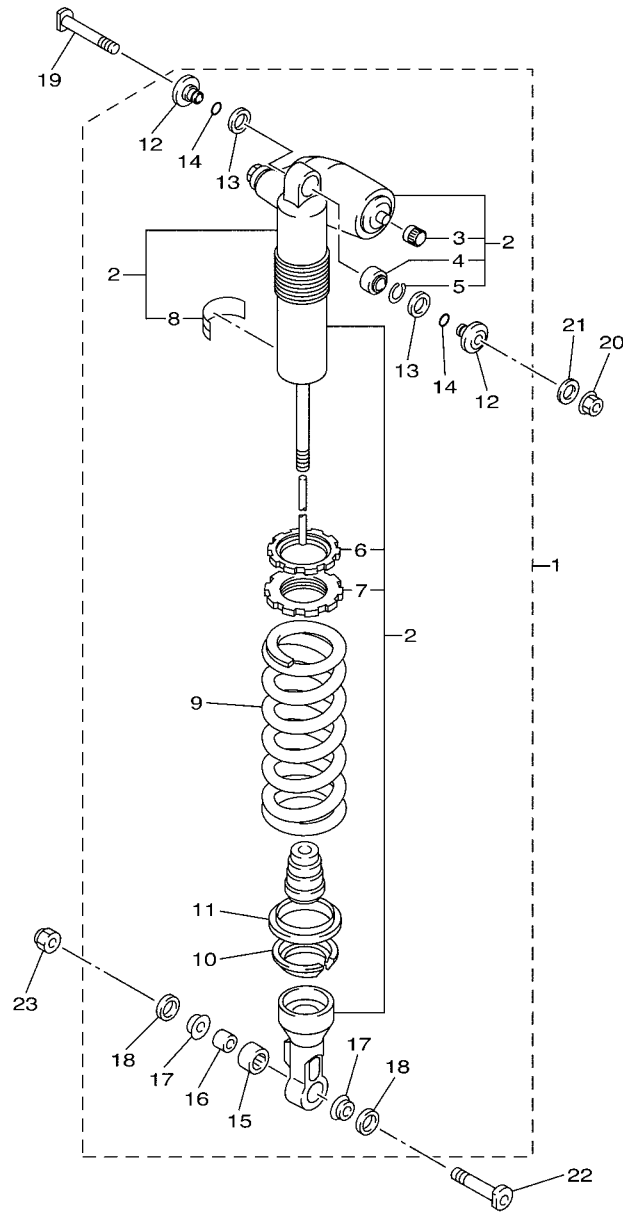

33D1110-J230

FIG. 23 REAR SUSPENSION

REF. NO.	PART NO.	DESCRIPTION	33DD			REMARKS
1	33D-22200-80	SHOCK ABSORBER ASSY, REAR	1			UR FOR DPBSE
	33D-22200-C0	SHOCK ABSORBER ASSY, REAR	1			UR FOR PWS1
2	33D-22201-40	.DAMPER SUB ASSY	1			
3	509-23184-L0	..CAP, AIR VALVE	1			
4	4JX-22226-00	..BUSH, SHOCK ABSORBER LOWER	1			
5	5DH-23183-00	..CIRCLIP	1			
6	33D-22234-00	..GUIDE, SPRING 3	1			
7	33D-22213-00	..SEAT, SPRING UPPER	1			
8	4AA-22259-80	..LABEL, WARNING	1			
9	33D-22212-30	.SPRING (K=56N/MM)	1			UR FOR DPBSE
	33D-22212-D0	.SPRING (K=56N/MM)	1			UR FOR PWS1
10	33D-22214-00	.GUIDE, SPRING 1	1			
11	33D-22224-00	.GUIDE, SPRING 2	1			
12	1C3-22253-50	.COLLAR, DISTANCE	2			
13	3JE-22475-00	.SEAL, DUST	2			
14	4EW-22474-00	.SEAL, RING	2			
15	5UN-22176-00	.BEARING	1			
16	5MV-22184-00	.BUSH	1			
17	1C3-22253-L1	.COLLAR, DISTANCE	2			
18	5NY-22475-00	.SEAL, DUST	2			
19	5XE-22242-00	BOLT 2	1			
20	95602-10200	NUT, U FLANGE	1			
21	92902-10200	WASHER	1			
22	5NY-22241-00	BOLT 1	1			
23	90185-10012	NUT, SELF-LOCKING	1			

FIG. 24 STEERING

REF. NO.	PART NO.	DESCRIPTION	33DD				REMARKS
1	93332-00081	BEARING	1				
2	17D-23389-50	GUIDE, CABLE	1				
3	90105-06170	BOLT, FLANGE	1				
4	90387-06105	COLLAR	1				
5	93332-00068	BEARING	1				
6	17D-23416-50	COVER, BALL RACE 2	1				
7	90179-28015	NUT	1				
8	90201-286K9	WASHER, PLATE (T1.0)	1				
9	33D-23435-00	CROWN, HANDLE	1				
10	90179-24004	NUT	1				
11	18P-23441-00	HOLDER, HANDLE UPPER	2				
12	33D-23442-00	HOLDER, HANDLE LOWER	2				
13	92902-10200	WASHER	2				
14	95602-10200	NUT, U FLANGE	2				
15	5YU-2143A-00	CAP	1				
16	90105-08154	BOLT, FLANGE	8				
17	17D-23485-50	PLATE, NUMBER	1				
18	90105-06064	BOLT, FLANGE	1				
19	33D-23472-00	PROTECTOR	1				
20	17D-2339R-00	GRAPHIC SET, 1	1				FOR PWS1

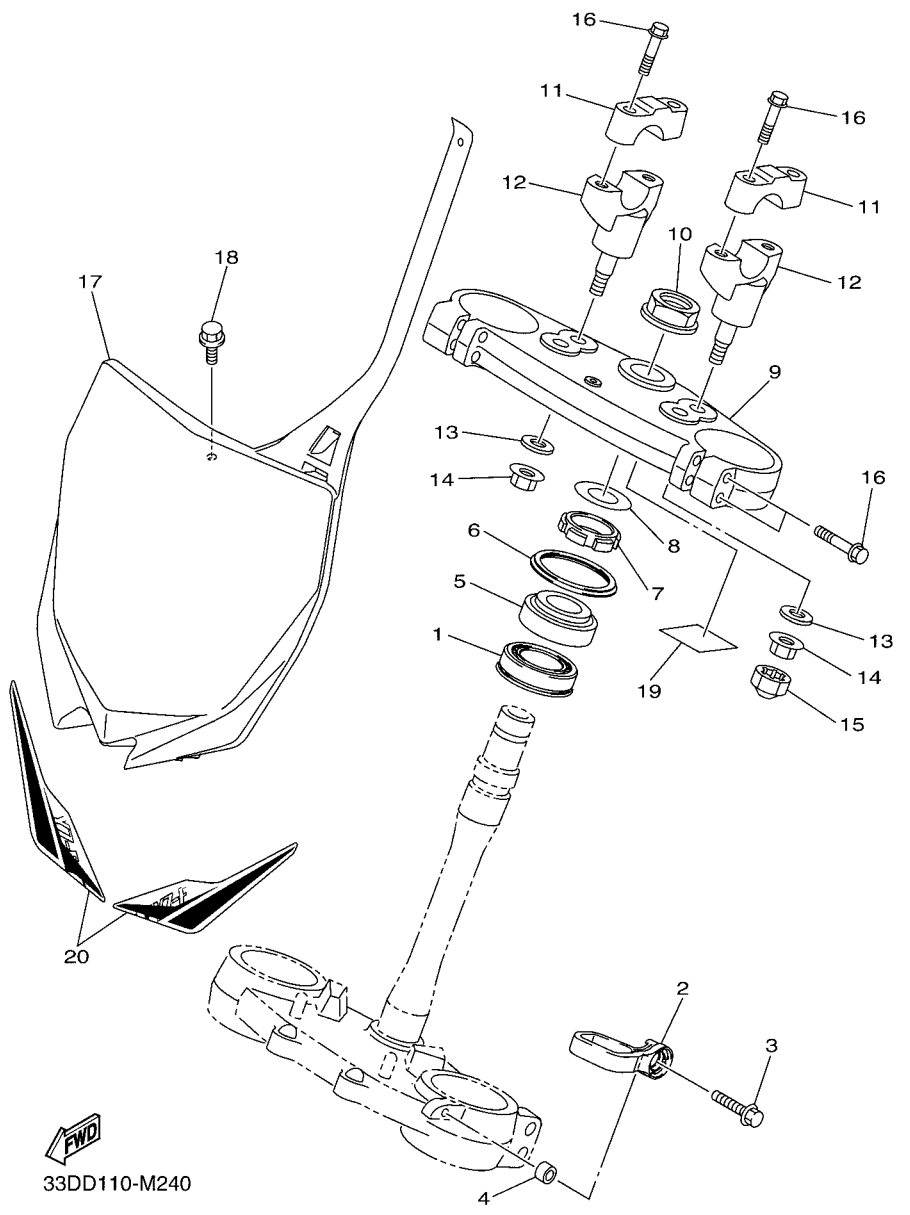

33DD110-M240

FIG. 25 FRONT FORK

REF. NO.	PART NO.	DESCRIPTION	33DD				REMARKS
1	33D-23102-20	FRONT FORK ASSY (L.H)	1				
2	33D-23136-00	.TUBE, OUTER (RIGHT)	1				
3	17D-23153-00	.RING, SNAP	1				
4	33D-23120-10	.INNER TUBE COMP.2	1				
5	5XE-23171-L0	.PISTON, FRONT FORK	1				
6	5XE-23125-L0	.METAL, SLIDE 1	1				
7	5XC-23146-10	.WASHER, OIL SEAL	1				
8	17D-23145-00	.OIL SEAL	1				
9	5XE-23153-L0	.RING, SNAP	1				
10	5XE-23144-L0	.SEAL, DUST	1				
11	33D-23170-20	.CYLINDER COMP., FRONT FORK	1				
12	1C3-23147-L0	..O-RING	1				
13	1C3-23142-L0	..SEAT, SPRING UPPER	1				
14	33D-2316A-20	.VALVE COMP.	1				
15	1C3-23188-L0	..O-RING	1				
16	1C3-23188-N0	..O-RING	1				
17	1C3-23188-P0	..O-RING	1				
18	1C3-23188-R0	..O-RING	1				
19	1AE-23147-00	..O-RING	2				
20	1C3-23190-L0	..AIR VALVE COMP.	1				
21	33D-23141-D0	.SPRING, FRONT FORK(K=4.6N/MM)	1				
22	5XC-23111-00	.BOLT, CAP	1				
23	2HH-23158-L0	..GASKET	1				
24	276-23114-00	..GASKET	1				
25	33D-23103-20	FRONT FORK ASSY (R.H)	1				
26	33D-23136-00	.TUBE, OUTER (RIGHT)	1				
27	17D-23153-00	.RING, SNAP	1				

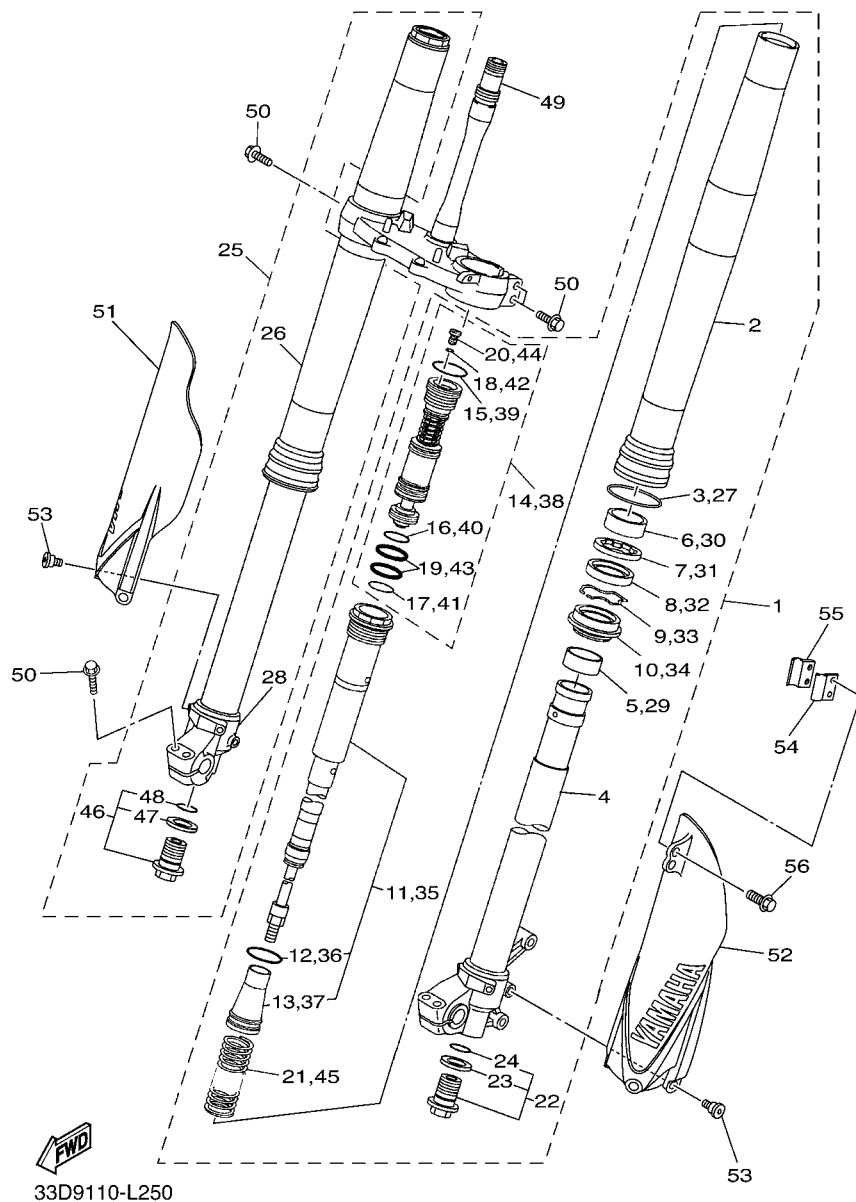
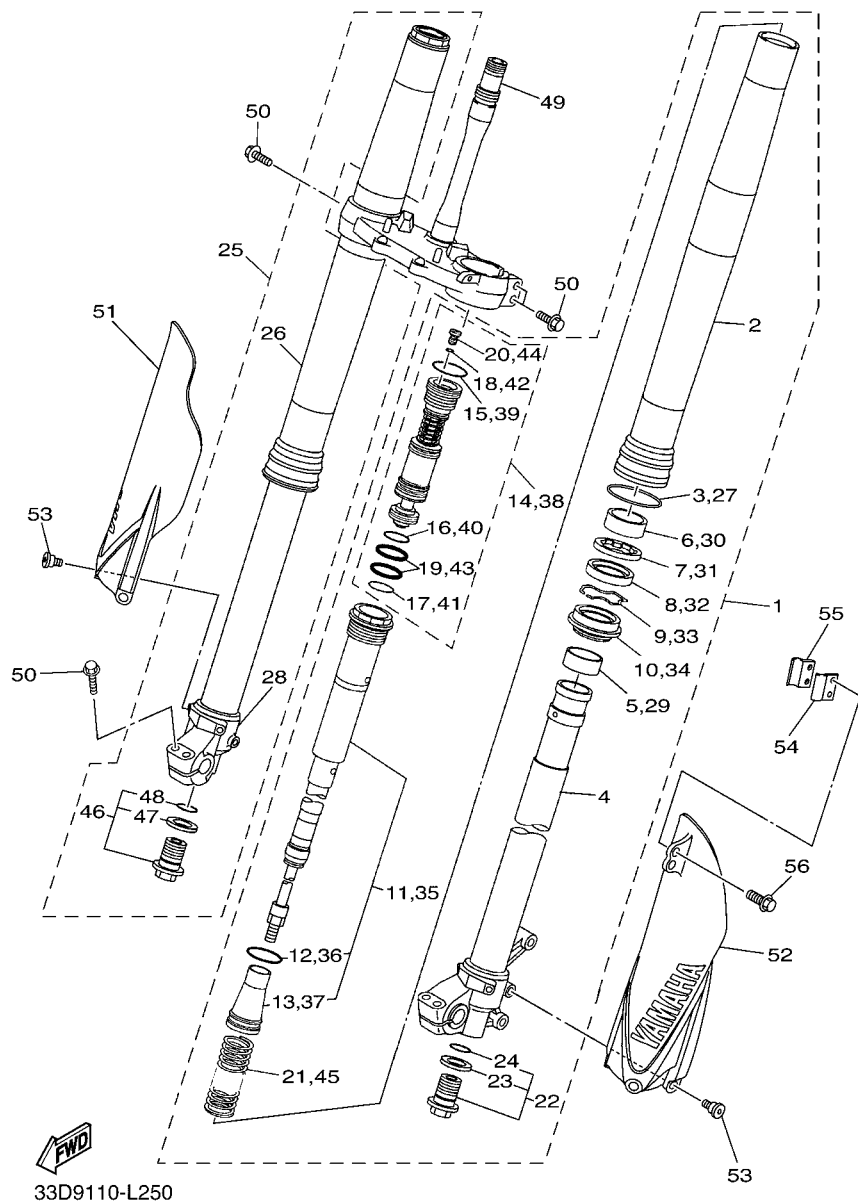

FIG. 25 FRONT FORK



REF. NO.	PART NO.	DESCRIPTION	33DD				REMARKS
28	33D-23110-10	.INNER TUBE COMP.1	1				
29	5XE-23171-L0	.PISTON, FRONT FORK	1				
30	5XE-23125-L0	.METAL, SLIDE 1	1				
31	5XC-23146-10	.WASHER, OIL SEAL	1				
32	17D-23145-00	.OIL SEAL	1				
33	5XE-23153-L0	.RING, SNAP	1				
34	5XE-23144-L0	.SEAL, DUST	1				
35	33D-23170-20	.CYLINDER COMP., FRONT FORK	1				
36	1C3-23147-L0	..O-RING	1				
37	1C3-23142-L0	..SEAT, SPRING UPPER	1				
38	33D-2316A-20	.VALVE COMP.	1				
39	1C3-23188-L0	..O-RING	1				
40	1C3-23188-N0	..O-RING	1				
41	1C3-23188-P0	..O-RING	1				
42	1C3-23188-R0	..O-RING	1				
43	1AE-23147-00	..O-RING	2				
44	1C3-23190-L0	..AIR VALVE COMP.	1				
45	33D-23141-D0	.SPRING, FRONT FORK(K=4.6N/MM)	1				
46	5XC-23111-00	.BOLT, CAP	1				
47	2HH-23158-L0	..GASKET	1				
48	276-23114-00	..GASKET	1				
49	33D-23340-00	UNDER BRACKET COMP.	1				
50	90105-08154	BOLT, FLANGE	8				
51	17D-2315J-50	PROTECTOR 2	1				UR FOR DPBSE
	17D-2315J-H0	PROTECTOR 2	1				UR FOR PWS1
52	17D-2315H-50	PROTECTOR 1	1				UR FOR DPBSE
	17D-2315H-H0	PROTECTOR 1	1				UR FOR PWS1

FIG. 25 FRONT FORK

REF. NO.	PART NO.	DESCRIPTION	33DD				REMARKS
53	90109-06232	BOLT	6				
54	17D-23466-00	CLAMP	1				
55	17D-23467-00	CLAMP	1				
56	90105-06170	BOLT, FLANGE	2				

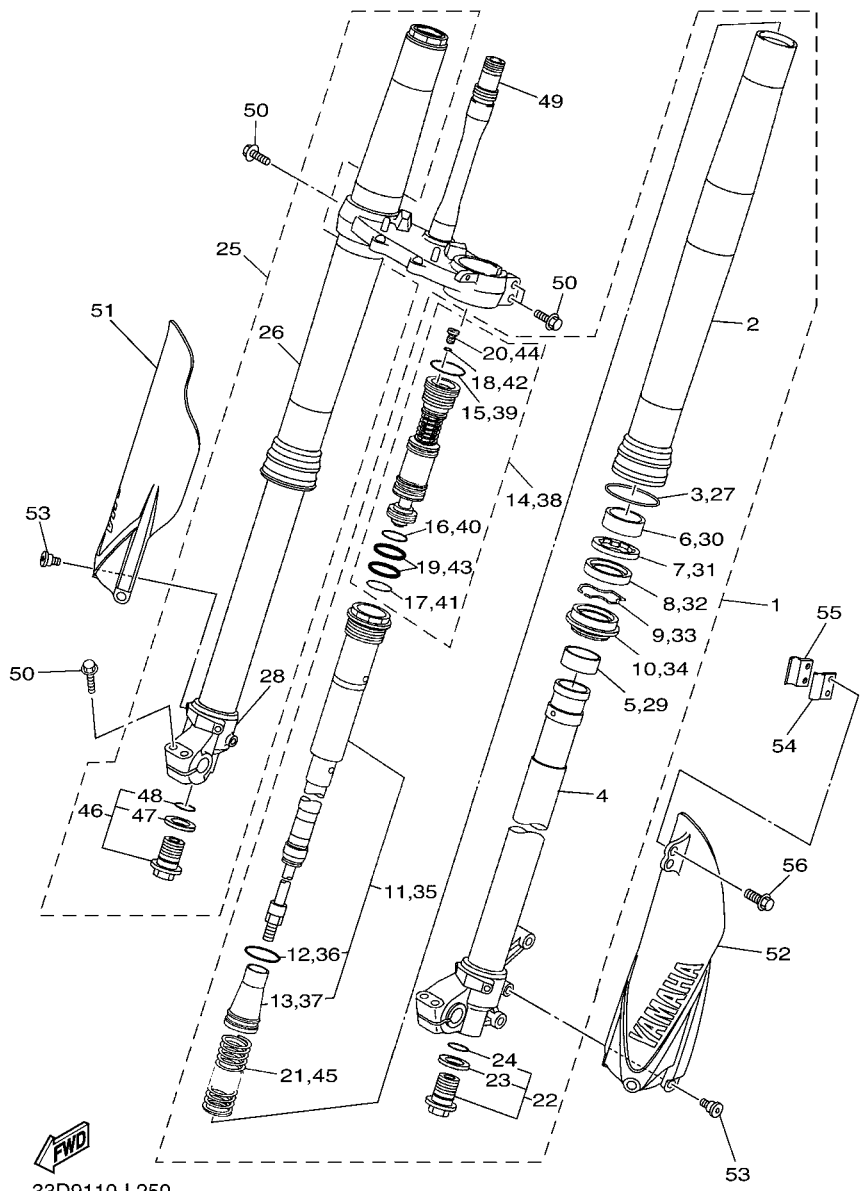

33D9110-L250

FIG. 26 FUEL TANK

REF. NO.	PART NO.	DESCRIPTION	33DD				REMARKS
1	33D-24110-50	FUEL TANK COMP.	1				
2	5NY-24610-10	CAP ASSY	1				
3	90445-09003	HOSE (L30)	1				
4	3XJ-24380-00	PIPE JOINT ASSY	1				
5	90445-09005	HOSE	1				
6	33D-24144-00	HOLDER, DAMPER	2				
7	90387-06091	COLLAR	2				
8	90480-18549	GROMMET	2				
9	90111-06007	BOLT,HEX. SOCKET BUTTON	4				
10	33D-2419A-00	HOLDER	1				
11	90111-06007	BOLT,HEX. SOCKET BUTTON	2				
12	95022-06025	BOLT, FLANGE	2				
13	90387-06236	COLLAR	2				
14	90480-01023	GROMMET	2				
15	33D-13907-00	FUEL PUMP COMP.	1				
16	33D-24486-00	O-RING	1				
17	33D-24491-00	BRACKET, FUEL PUMP	1				
18	33D-24192-00	BRACKET, FUEL TANK 2	1				
19	90154-05012	SCREW, BINDING	2				
20	90110-05058	BOLT, HEXAGON SOCKET HEAD	6				
21	33D-13971-00	PIPE, FUEL 1	1				
22	33D-24135-00	CLAMP 1	1				
23	4EW-2412F-00	BRACKET, SEAT	1				
24	98702-06025	SCREW, FLAT HEAD	1				
25	33D-24217-00	COVER	1				
26	33D-24665-00	.DAMPER	1				
27	90269-07001	RIVET	2				

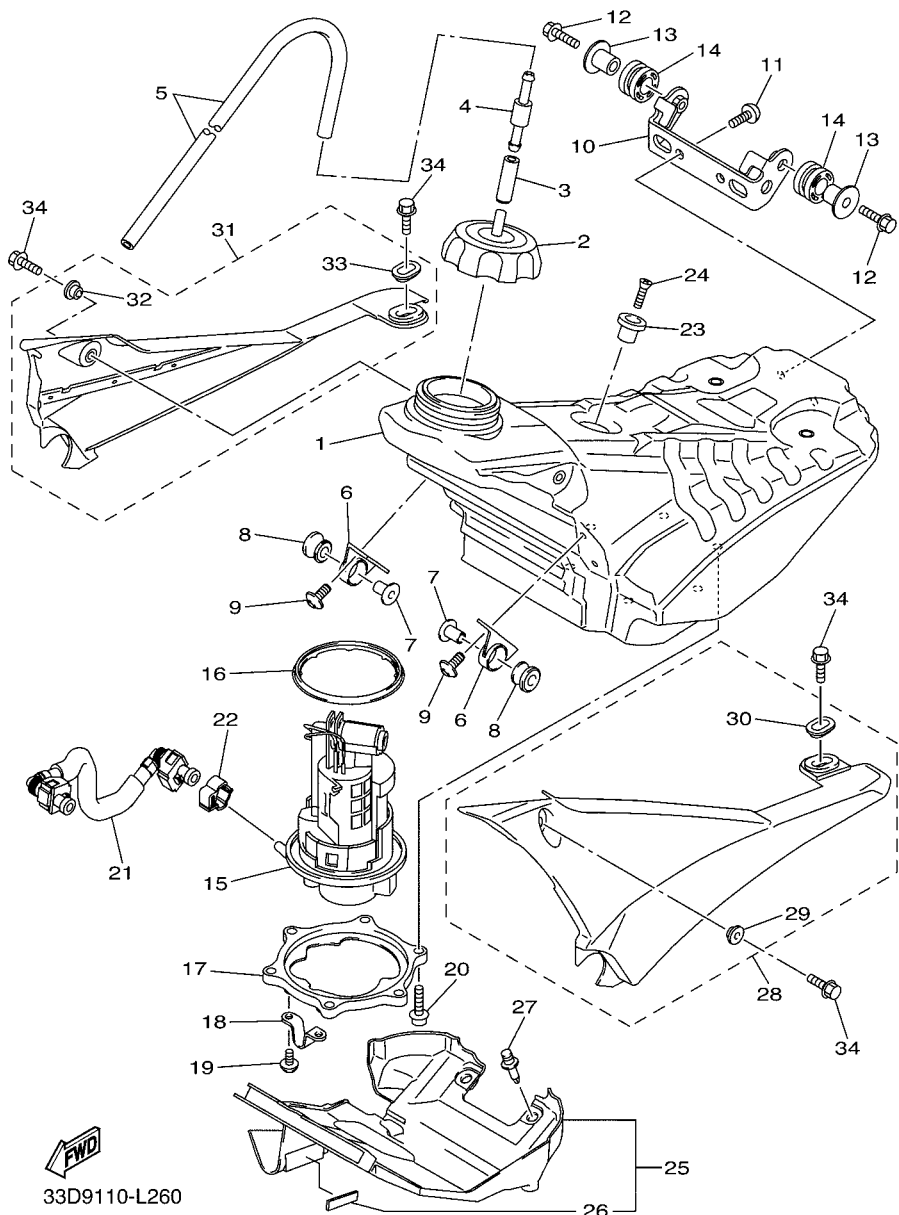
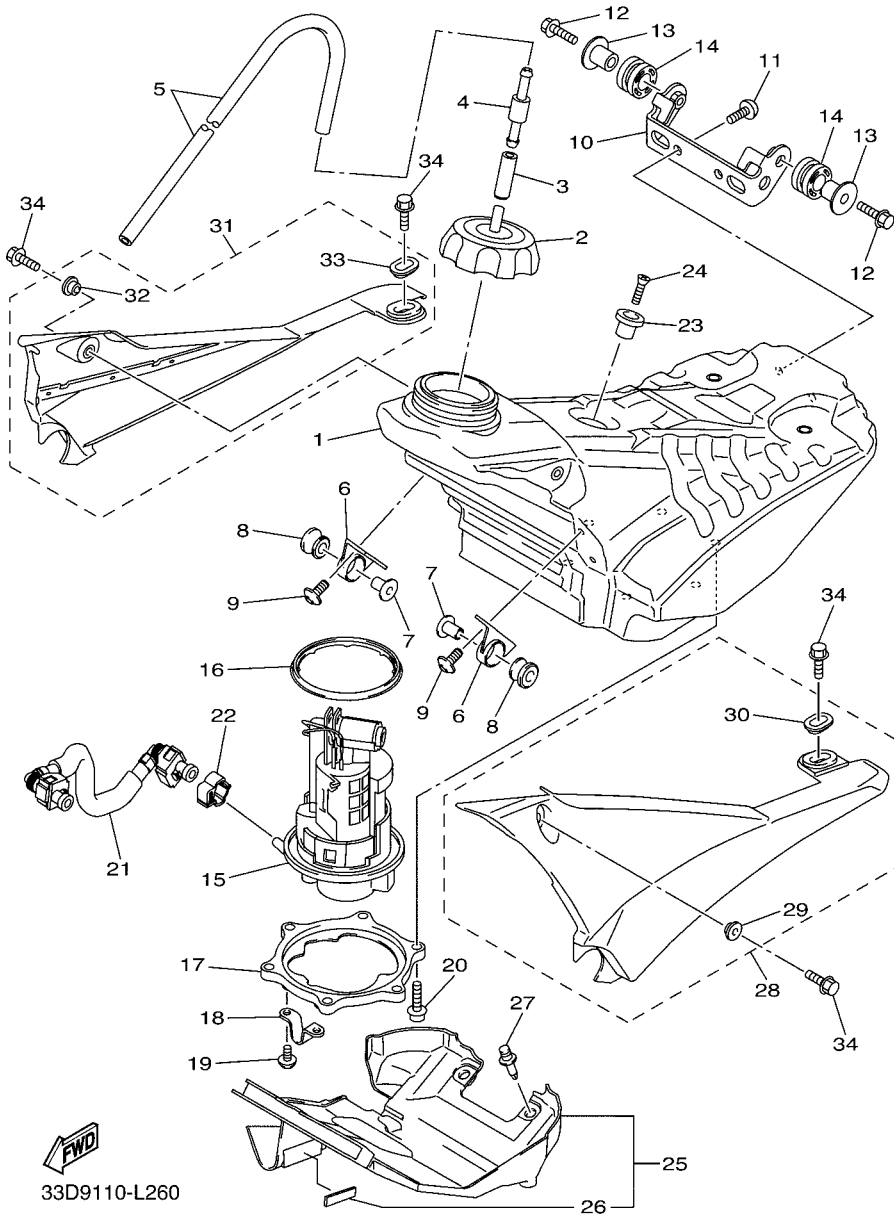

FIG. 26 FUEL TANK

REF. NO.	PART NO.	DESCRIPTION	33DD			REMARKS
28	33D-24106-50	TANK SIDE COVER ASSY 1	1			UR FOR DPBSE
	33D-24106-10	TANK SIDE COVER ASSY 1	1			UR FOR PWS1
29	90387-06009	.COLLAR	1			
30	5XC-21749-90	.COLLAR	1			
31	33D-24108-50	TANK SIDE COVER ASSY 2	1			UR FOR DPBSE
	33D-24108-10	TANK SIDE COVER ASSY 2	1			UR FOR PWS1
32	90387-06009	.COLLAR	1			
33	5XC-21749-90	.COLLAR	1			
34	90105-06064	BOLT, FLANGE	4			



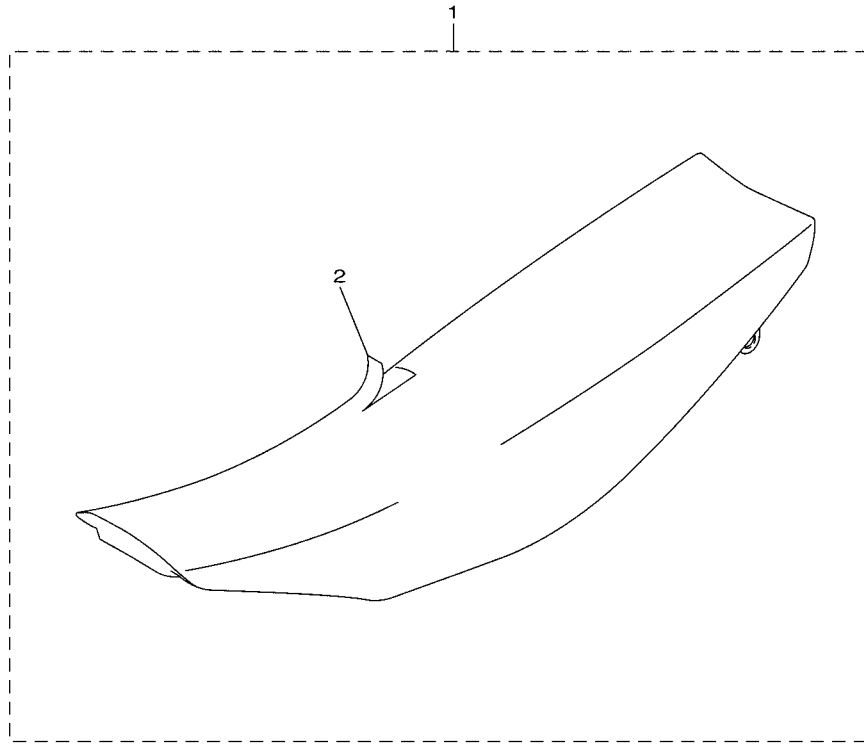

FIG. 27 SEAT

REF. NO.	PART NO.	DESCRIPTION	33DD			REMARKS
1	33D-24710-90	SINGLE SEAT ASSY	1			UR FOR DPBSE
	33D-24710-A0	SINGLE SEAT ASSY	1			UR FOR PWS1
2	33D-2470F-50	.SEAT COVER COMP.	1			UR FOR DPBSE
	33D-2470F-A0	.SEAT COVER COMP.	1			UR FOR PWS1



33D1110-J270

FIG. 28 FRONT WHEEL

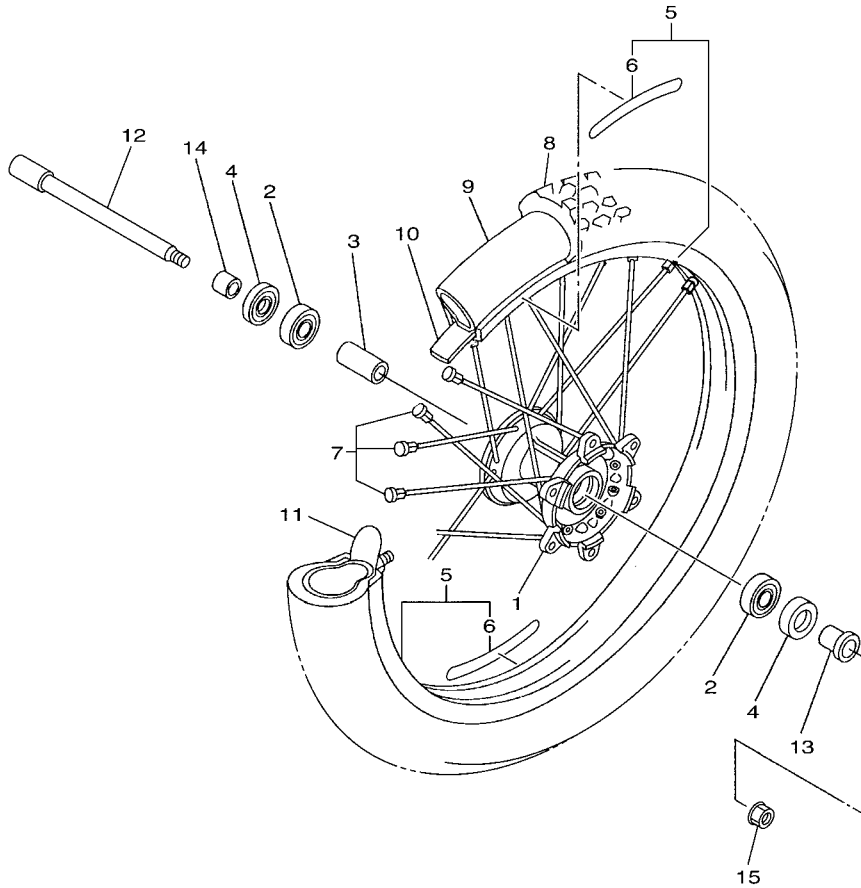

REF. NO.	PART NO.	DESCRIPTION	33DD				REMARKS
1	5NY-25111-00	HUB, FRONT	1				
2	93306-90409	BEARING	2				
3	5NY-25117-00	SPACER, BEARING	1				
4	93102-26468	OIL SEAL	2				
5	94416-21045	RIM (1.60-21)	1				
6	17D-2531B-00	.EMBLEM, WHEEL	2				
7	5NY-25104-00	SPOKE SET, FRONT	1				
8	94108-21028	TIRE (80/100-21 51M MX51FG)	1				DUNLOP
9	94227-21101	TUBE (80/100-21 M/C TR4)	1				DUNLOP
10	94309-21161	BAND, RIM (22-21)	1				DUNLOP
11	5SF-25394-00	SPACER, BEAD	1				
12	5XC-25181-G0	AXLE, WHEEL	1				
13	5XC-25183-G0	COLLAR, WHEEL	1				
14	5XC-25186-G0	COLLAR, WHEEL	1				
15	90179-16011	NUT	1				



33D9110-L280

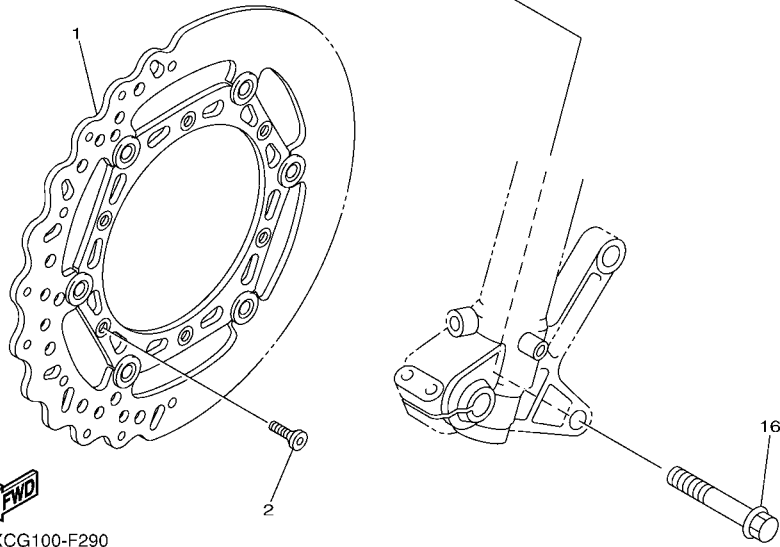
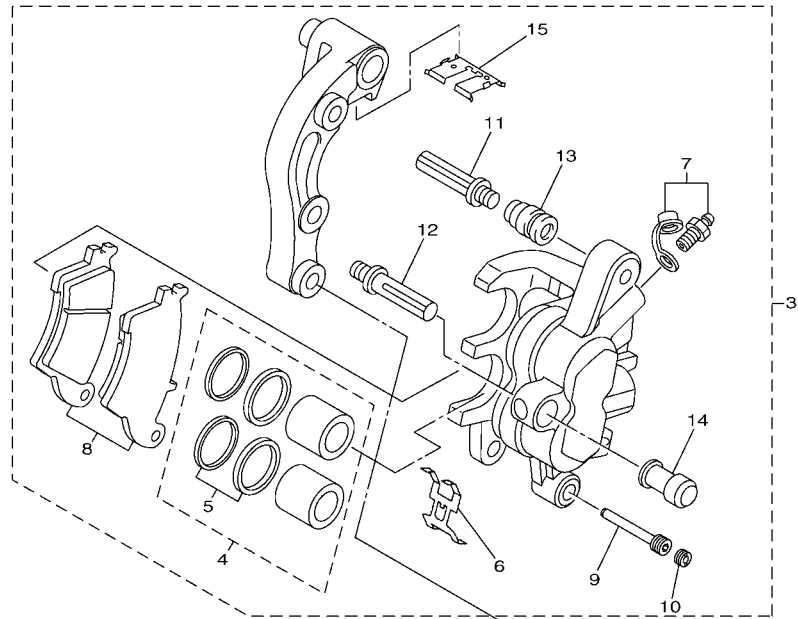

FIG. 29 FRONT BRAKE CALIPER

REF. NO.	PART NO.	DESCRIPTION	33DD				REMARKS
1	5XC-2581T-G0	DISK BRAKE ASSY	1				
2	90151-06051	SCREW, COUNTERSUNK	6				
3	5XC-2580T-G0	CALIPER ASSY (LEFT)	1				
4	5XC-W0057-00	.PISTON ASSY, CALIPER	1				
5	5KM-W0047-10	..CALIPER SEAL KIT	1				
6	5DH-25919-00	.SUPPORT, PAD	1				
7	1UY-W0048-50	.BLEED SCREW KIT	1				
8	5XC-W0045-00	.BRAKE PAD KIT	1				
9	5DH-25933-00	.PIN, PAD	1				
10	5DH-25916-00	.PLUG	1				
11	3SP-25926-51	.BOLT	1				
12	3SP-25914-51	.PIN, SLIDE	1				
13	3JD-25917-00	.BOOT, CALIPER	1				
14	1UY-25937-51	.BOOT 2	1				
15	5XC-25849-G0	.RETAINER, CALIPER	1				
16	90105-08137	BOLT, FLANGE	2				

FIG. 30 REAR WHEEL

REF. NO.	PART NO.	DESCRIPTION	33DD				REMARKS
1	17D-25311-00	HUB, REAR	1				
2	17D-25317-00	SPACER, BEARING	1				
3	93306-90510	BEARING	3				
4	93102-32337	OIL SEAL	2				
5	99009-42700	CIRCLIP	1				
6	17D-25448-50	SPROCKET, DRIVEN (48T)	1				STD
	17D-25447-50	SPROCKET, DRIVEN (47T)	1				AP
	17D-25449-50	SPROCKET, DRIVEN (49T)	1				AP
	17D-25450-50	SPROCKET, DRIVEN (50T)	1				AP
	17D-25451-50	SPROCKET, DRIVEN (51T)	1				AP
	17D-25452-50	SPROCKET, DRIVEN (52T)	1				AP
7	90109-08078	BOLT	6				
8	90185-08008	NUT, SELF-LOCKING	6				
9	90201-08048	WASHER, PLATE	6				
10	34P-25304-00	SPOKE SET, REAR	1				
11	94421-19013	RIM (2.15-19)	1				
12	17D-2531B-00	.EMBLEM, WHEEL	2				
13	94112-19009	TIRE (120/80-19 63M MX51)	1				DUNLOP
14	94211-19273	TUBE (110/90-19 M/C TR4)	1				DUNLOP
15	94311-19155	BAND, RIM (2.5-19)	1				DUNLOP
16	3JE-25394-00	SPACER, BEAD	1				
17	4XM-25364-00	DAMPER	1				
18	90480-08608	GROMMET	1				
19	17D-2530S-00	COLLAR ASSY	2				
20	17D-25388-00	PULLER, CHAIN 1	1				
21	33D-25389-00	PULLER, CHAIN 2	1				
22	90101-08006	BOLT	2				

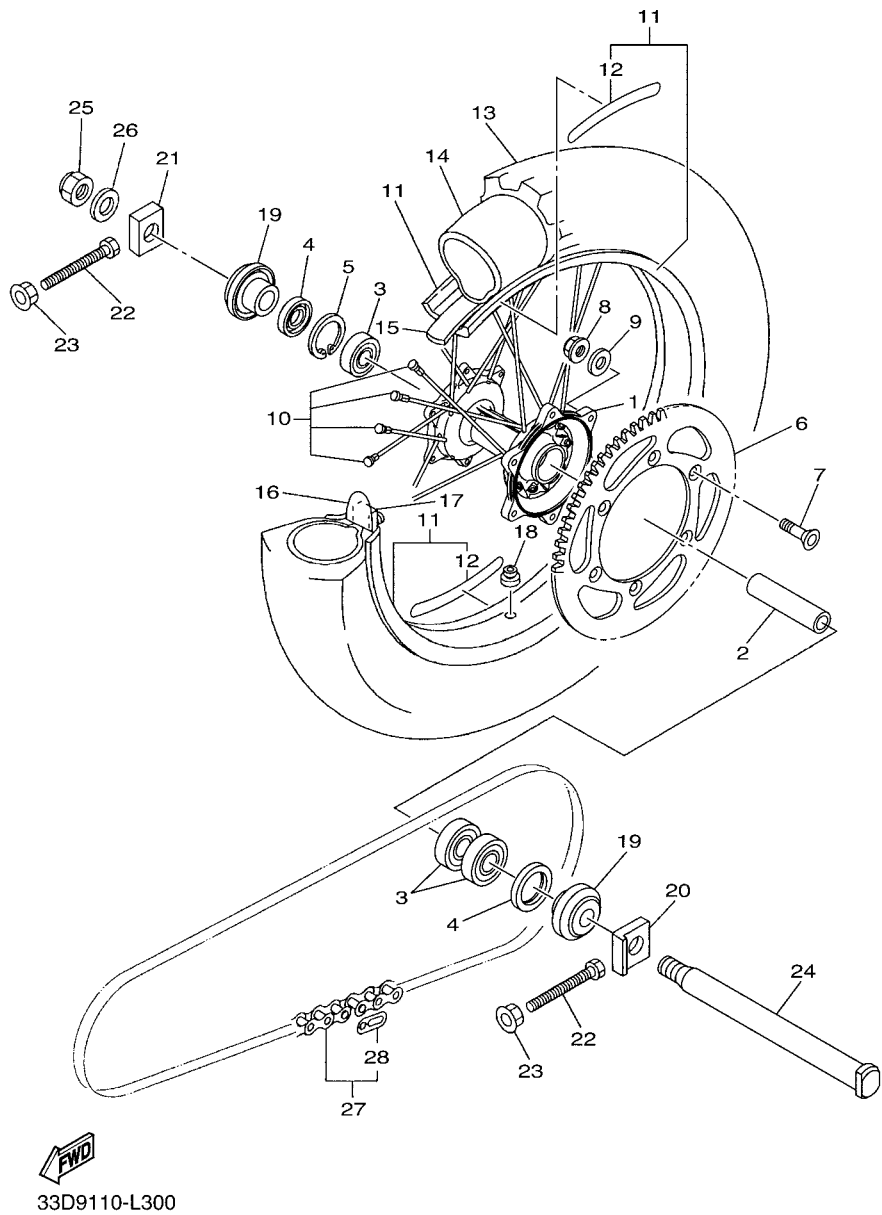
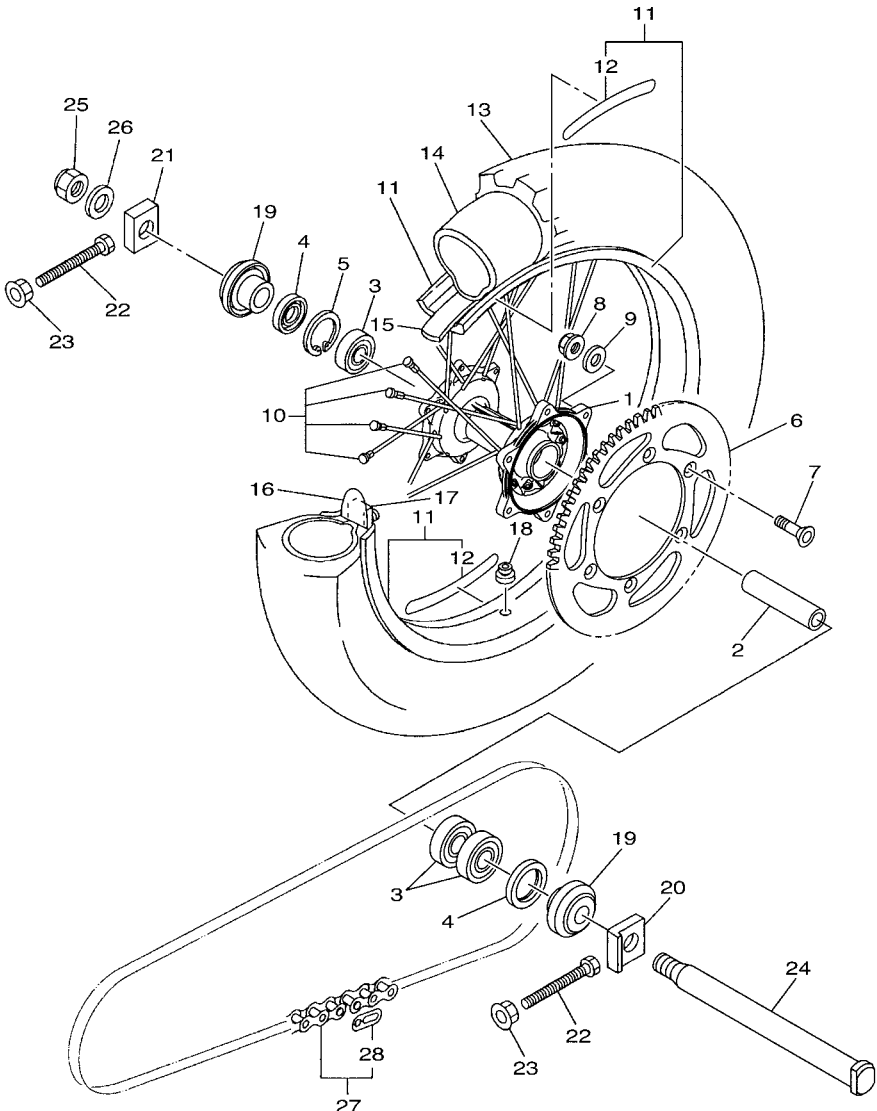
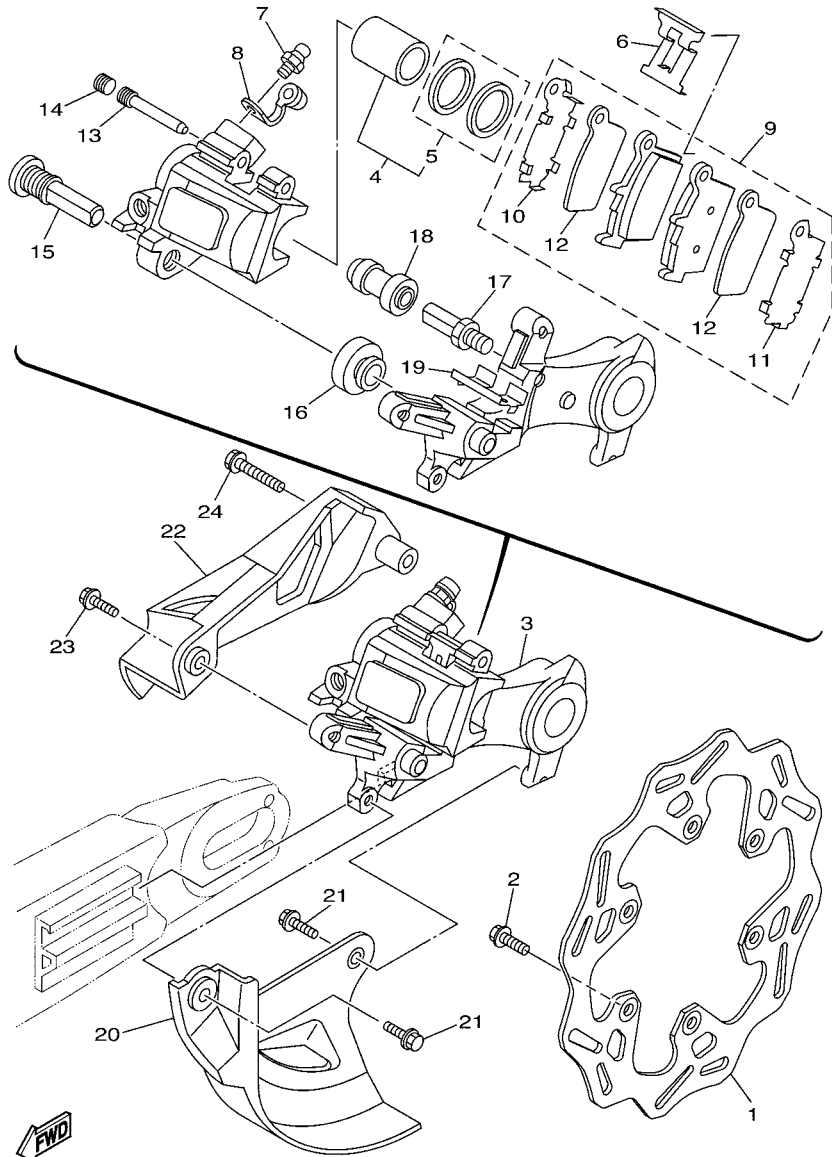

FIG. 30 REAR WHEEL

REF. NO.	PART NO.	DESCRIPTION	33DD			REMARKS
23	90179-08019	NUT	2			
24	17D-25381-00	AXLE, WHEEL	1			
25	90185-22011	NUT, SELF-LOCKING	1			
26	90201-22023	WASHER, PLATE	1			
27	9Y582-28113	CHAIN (DID520DMA2-114LL)	1			
28	94682-28001	.JOINT, CHAIN(DID520DM G&B-RJ)	1			



33D9110-L300



33DD110-M310

FIG. 31 REAR BRAKE CALIPER

REF. NO.	PART NO.	DESCRIPTION	33DD				REMARKS
1	2S2-2582W-70	DISK, REAR BRAKE 2	1				
2	90105-06156	BOLT, FLANGE	6				
3	17D-2580W-01	CALIPER ASSY, REAR 2	1				
4	5UN-W0057-50	.PISTON ASSY, CALIPER	1				
5	5UN-W0047-50	..CALIPER SEAL KIT	1				
6	5DH-25919-50	..SUPPORT, PAD	1				
7	1UY-25824-51	.SCREW, BLEED	1				
8	1UY-25825-51	.CAP	1				
9	1C3-W0046-50	.BRAKE PAD KIT 2	1				
10	5UN-25828-60	..SHIM, CALIPER	1				
11	5UN-25827-60	..SHIM, CALIPER	1				
12	5UN-22898-60	..INSULATOR, HEAT	2				
13	8CR-25924-00	.PIN, PAD	1				
14	5DH-25916-00	.PLUG	1				
15	5DH-25914-50	.PIN, SLIDE	1				
16	3JD-25917-00	.BOOT, CALIPER	1				
17	5UN-25914-00	.PIN, SLIDE	1				
18	1UY-25937-51	.BOOT 2	1				
19	5UN-25913-00	.RETAINER	1				
20	17D-25718-50	PROTECTOR, DISK BRAKE	1				
21	90105-06110	BOLT, FLANGE	2				
22	17D-27491-50	PROTECTOR	1				
23	90105-06107	BOLT, FLANGE	1				
24	90105-06111	BOLT, FLANGE	1				

FIG. 32 STEERING HANDLE & CABLE

REF. NO.	PART NO.	DESCRIPTION	33DD				REMARKS
1	17D-26111-H0	HANDLEBAR	1				
2	4GY-26241-00	GRIP	1				
3	5TJ-26240-C0	GRIP ASSY	1				
4	4GY-26242-00	.GRIP (RIGHT)	1				
5	3Y1-26249-00	.RING, LEAF	1				
6	5BE-26281-01	CAP, GRIP UPPER	1				
7	5BE-26282-00	CAP, GRIP UNDER	1				
8	98507-05020	SCREW, PAN HEAD	2				
9	5SF-26287-11	COVER, CAP GRIP	1				
10	33D-26302-00	THROTTLE CABLE ASSY	1				
11	33D-26335-00	CABLE, CLUTCH	1				
12	34P-26342-00	BOOT, CABLE	1				
13	90387-225N2	COLLAR	1				
14	17D-26124-00	PROTECTOR, HANDLEBAR	1				
15	17D-26143-H0	COVER, HAND UPPER 1	1				

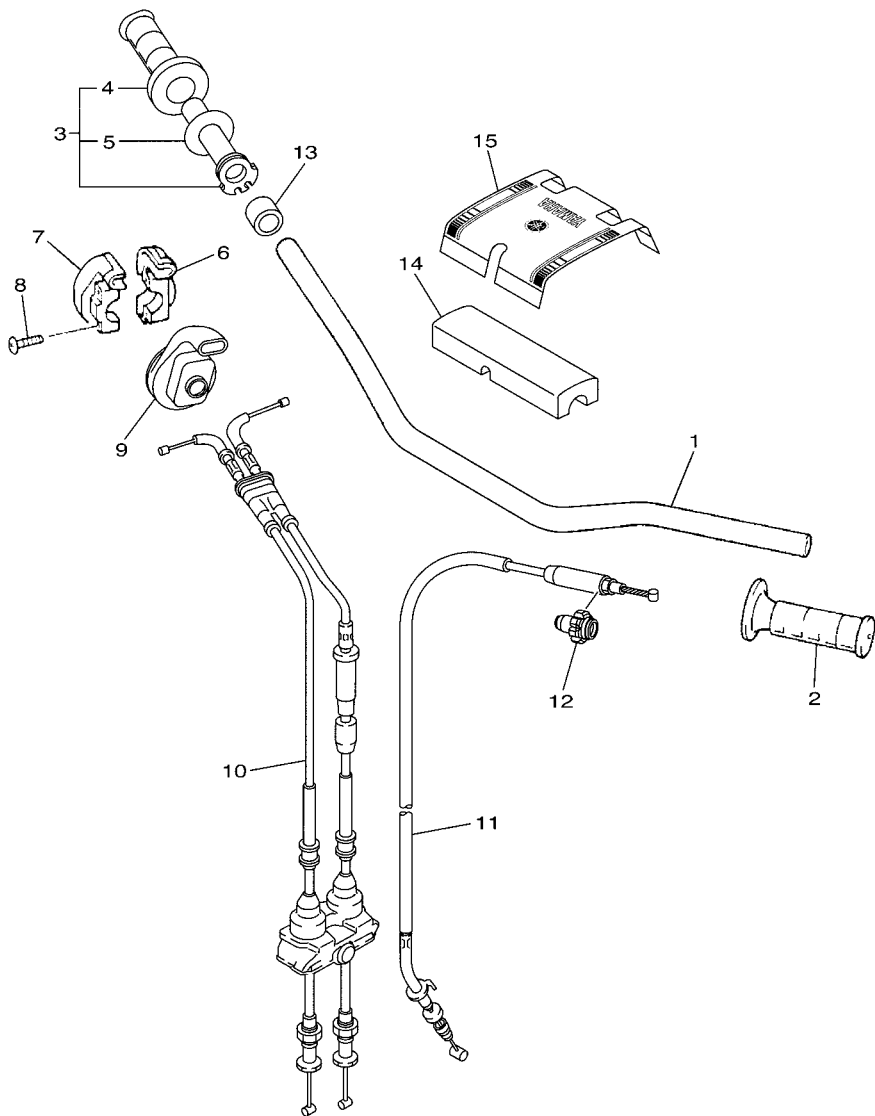

33DD110-M320

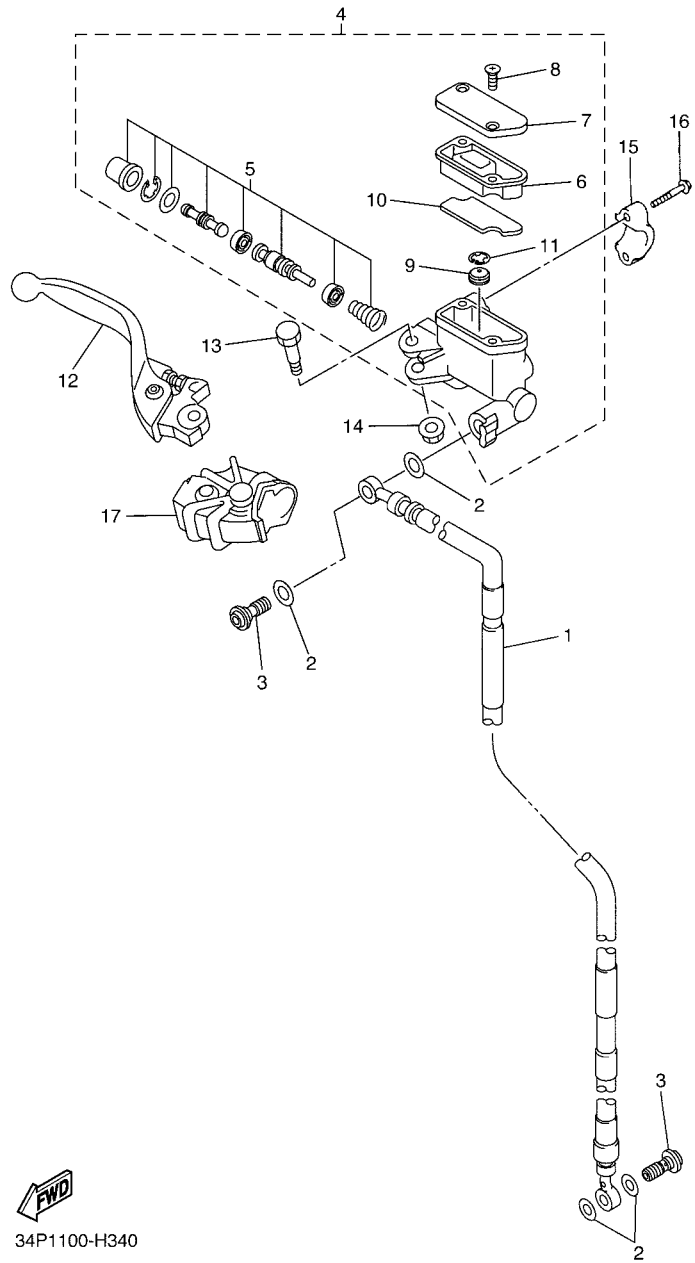

34P1100-H340

FIG. 33 FRONT MASTER CYLINDER

REF. NO.	PART NO.	DESCRIPTION	33DD				REMARKS
1	17D-25872-50	HOSE, BRAKE 1	1				
2	90430-10005	GASKET	4				
3	90401-10172	BOLT, UNION	2				
4	5XC-W2587-00	MASTER CYLINDER SUB ASSY	1				
5	5XC-W0041-00	.CYLINDER KIT, MASTER	1				
6	5XC-25854-G0	.DIAPHRAGM, RESERVOIR	1				
7	5XC-25852-G0	.CAP, RESERVOIR	1				
8	98706-04012	.SCREW, FLAT HEAD	2				
9	5CG-25715-00	.SEPARATOR ASSY	1				
10	5XC-25853-G0	.FLOAT, RESERVOIR	1				
11	5CG-2585G-00	.CIRCLIP	1				
12	5XC-83922-L0	LEVER 2	1				
13	5MV-2589F-00	BOLT, LEVER	1				
14	95701-06500	NUT, WITH WASHER	1				
15	5MV-25867-00	BRACKET, MASTER CYLINDER	1				
16	5MV-25833-00	BOLT, FITTING	2				
17	5XC-26372-G0	COVER, HANDLE LEVER 1	1				

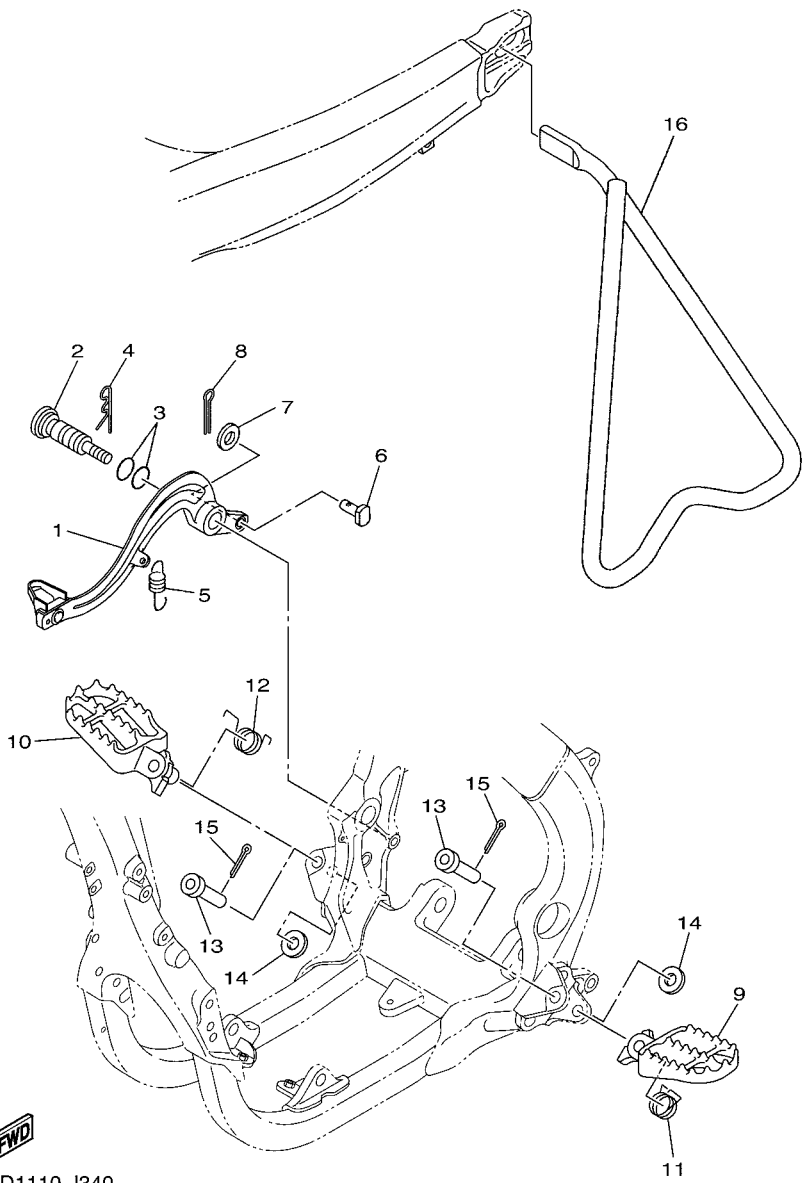

33D1110-J340

FIG. 34 STAND & FOOTREST

REF. NO.	PART NO.	DESCRIPTION	33DD				REMARKS
1	33D-27200-01	PEDAL, BRAKE	1				
2	17D-27217-00	BOLT	1				
3	93210-11073	O-RING	2				
4	90468-16001	CLIP	1				
5	90506-18019	SPRING, TENSION	1				
6	90240-08120	PIN, CLEVIS	1				
7	90201-08044	WASHER, PLATE	1				
8	91402-20012	PIN, COTTER	1				
9	17D-27411-00	FOOTREST 1	1				
10	17D-27421-00	FOOTREST 2	1				
11	90508-28015	SPRING, TORSION	1				
12	90508-28018	SPRING, TORSION	1				
13	90240-10004	PIN, CLEVIS	2				
14	90201-10032	WASHER, PLATE	2				
15	91402-25015	PIN, COTTER	2				
16	34P-27311-00	STAND, SIDE	1				

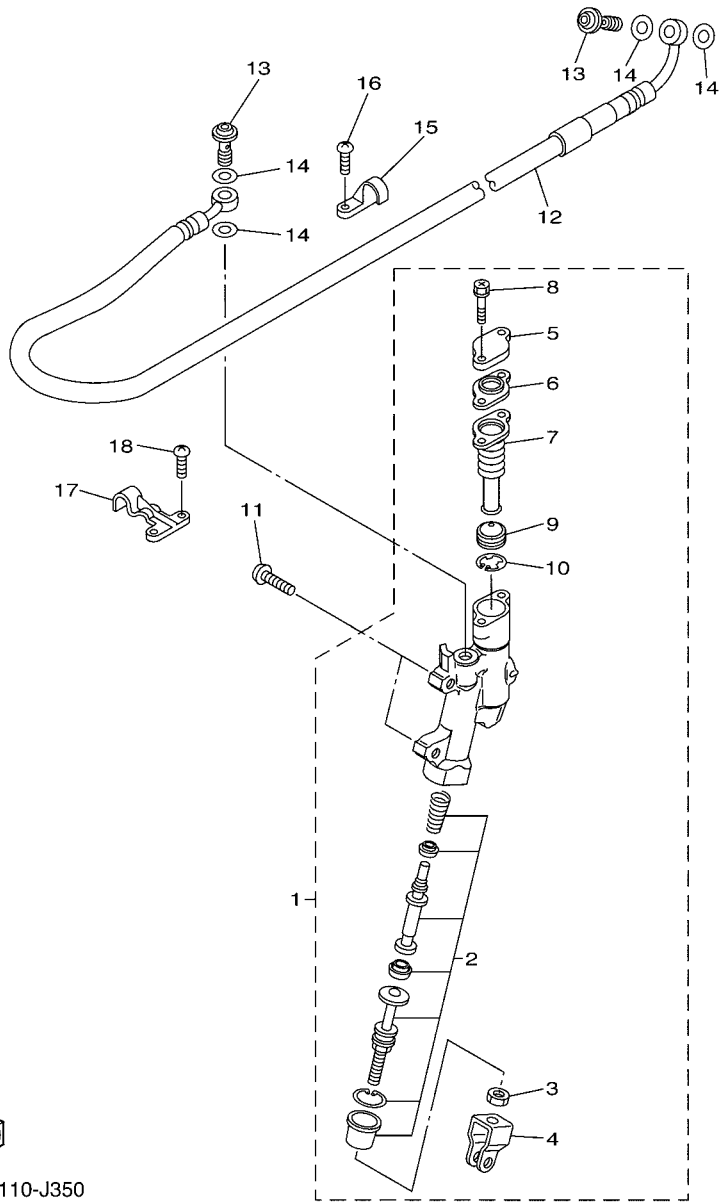

33D1110-J350

FIG. 35 REAR MASTER CYLINDER

REF. NO.	PART NO.	DESCRIPTION	33DD				REMARKS
1	33D-2583V-00	RR. MASTER CYLINDER ASSY.	1				
2	5UN-W0042-50	.CYLINDER KIT, MASTER	1				
3	5UN-27218-00	.NUT	1				
4	5UN-27222-00	.JOINT	1				
5	5UN-25852-50	.CAP, RESERVOIR	1				
6	5UN-2585B-00	.PLATE, DIAPHRAGM	1				
7	5UN-25854-00	.DIAPHRAGM, RESERVOIR	1				
8	5UN-27217-00	.BOLT	2				
9	5CG-25715-00	.SEPARATOR ASSY	1				
10	5CG-2585G-00	.CIRCLIP	1				
11	90111-06116	BOLT,HEX. SOCKET BUTTON	2				
12	5XC-25873-L0	HOSE, BRAKE 2	1				
13	90401-10172	BOLT, UNION	2				
14	90430-10005	GASKET	4				
15	1C3-25886-50	HOLDER, BRAKE HOSE	1				
16	98502-05010	SCREW, PAN HEAD	2				
17	1C3-25876-50	HOLDER, BRAKE HOSE 2	1				
18	98502-05010	SCREW, PAN HEAD	2				

FIG. 36 GENERATOR

REF. NO.	PART NO.	DESCRIPTION	33DD				REMARKS
1	33D-81410-00	STATOR ASSY	1				
2	33D-81450-00	ROTOR ASSY	1				
3	33D-81528-00	CLAMP 1	1				
4	90149-05031	SCREW	3				
5	90110-06161	BOLT, HEXAGON SOCKET HEAD	2				
6	90179-12657	NUT	1				
7	90201-127E1	WASHER, PLATE	1				

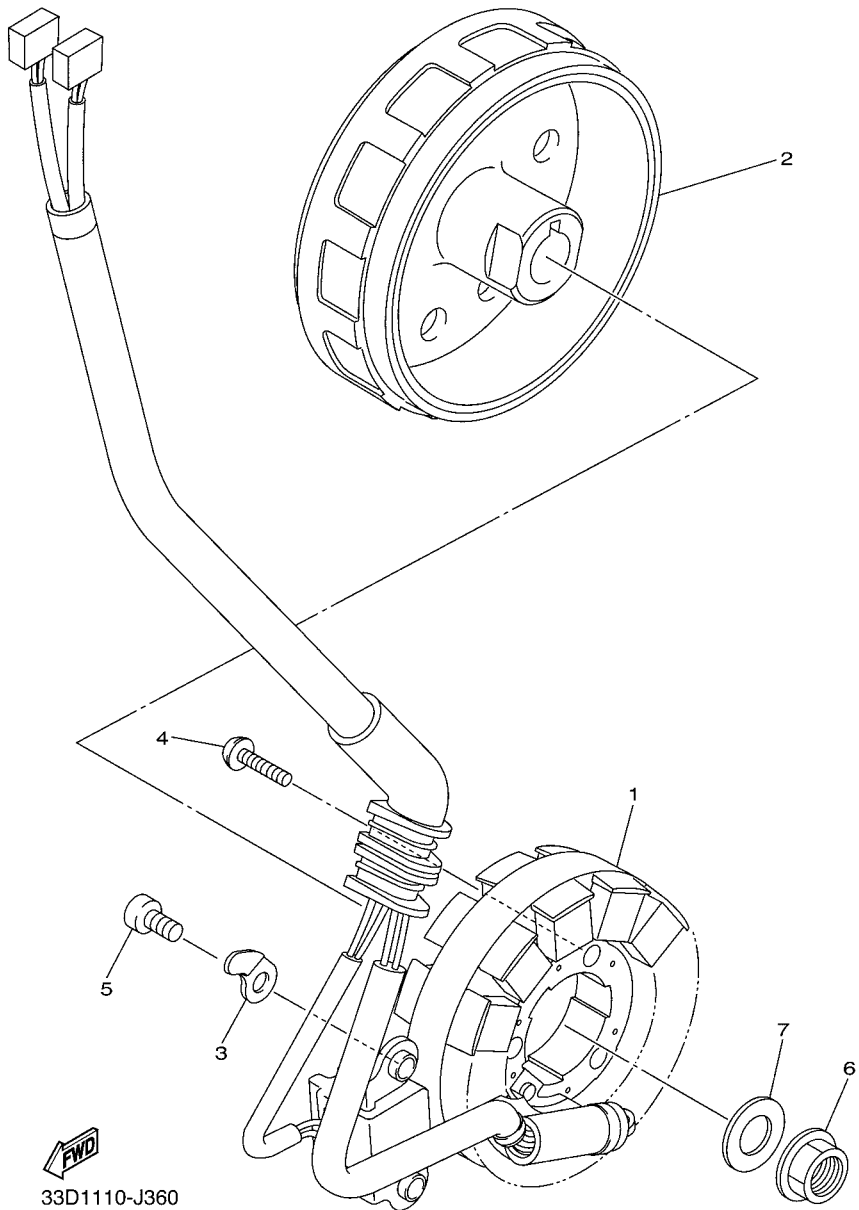

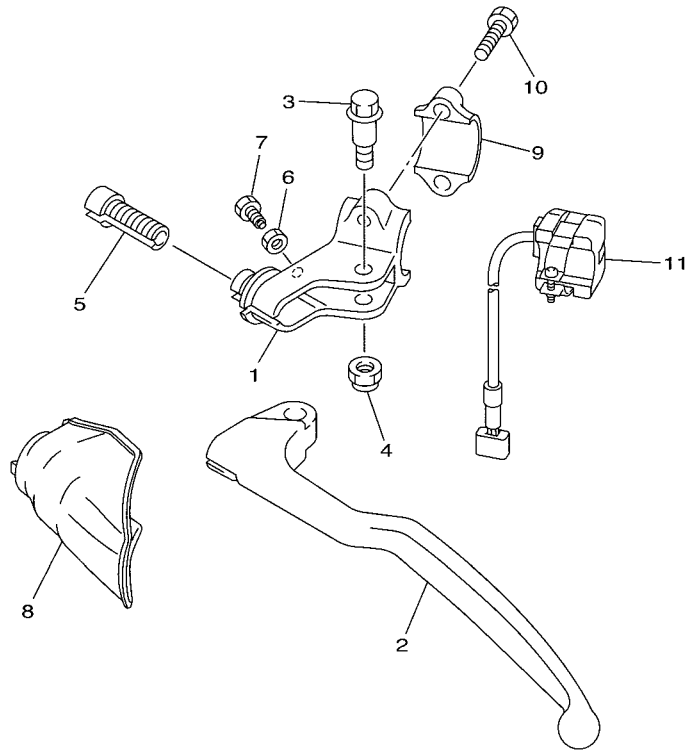

FIG. 37 HANDLE SWITCH & LEVER

REF. NO.	PART NO.	DESCRIPTION	33DD				REMARKS
1	17D-82911-00	HOLDER, LEVER 1	1				
2	17D-83912-00	LEVER 1	1				
3	90109-06034	BOLT	1				
4	5LP-84126-10	NUT, LENS FITTING	1				
5	17D-26337-00	BOLT, ADJUSTING	1				
6	95302-05600	NUT	1				
7	90101-05005	BOLT	1				
8	34P-26372-00	COVER, HANDLE LEVER 1	1				
9	33D-82913-00	HOLDER, LEVER LOWER 1	1				
10	95022-06020	BOLT, FLANGE	2				
11	33D-83976-01	SWITCH, HANDLE 1	1				



33D1110-J370

FIG. 38 ELECTRICAL 1

REF. NO.	PART NO.	DESCRIPTION	33DD				REMARKS
1	33D-8591A-70	ENGINE CONTROL UNIT ASSY	1				
2	92012-05025	BOLT, BUTTON HEAD	2				
3	90387-05048	COLLAR	2				
4	90480-13029	GROMMET	2				
5	90201-05043	WASHER, PLATE	2				
6	33D-82310-00	IGNITION COIL ASSY	1				
7	33D-82351-00	TUBE, CORD	1				
8	90480-11015	GROMMET	1				
9	33D-82370-00	PLUG CAP ASSY	1				
10	92012-05016	BOLT, BUTTON HEAD	2				
11	33D-13542-00	HOSE, VACUUM SENSING 1	1				
12	90467-07138	CLIP	1				
13	92012-05016	BOLT, BUTTON HEAD	1				
14	4P9-83591-00	THERMO UNIT	1				
15	90430-10004	GASKET	1				
16	2C0-82380-00	SENSOR, PRESSURE	1				
17	33D-82388-00	PLATE	1				
18	90105-06110	BOLT, FLANGE	1				
19	33D-81960-00	RECTIFIER & REGULATOR ASSY	1				
20	90105-06110	BOLT, FLANGE	2				
21	33D-81965-00	CONDENSER, SMOOTHING	1				
22	33D-82590-00	WIRE HARNESS ASSY	1				
23	33D-82378-00	CONNECTOR	1				
24	90464-13077	CLAMP	1				
25	90464-13073	CLAMP	1				
26	5Y9-12491-00	CLAMP 1	2				
27	90464-18002	CLAMP	2				

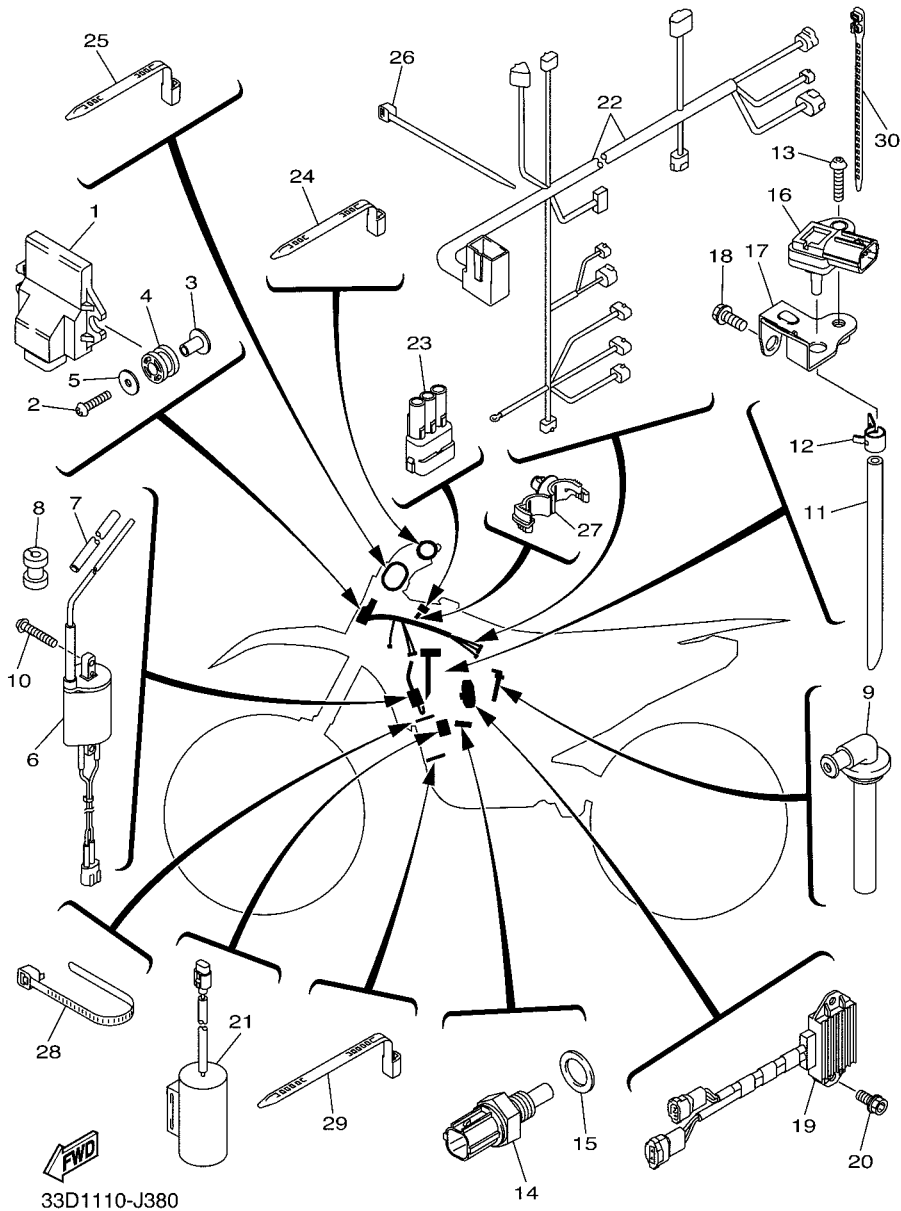
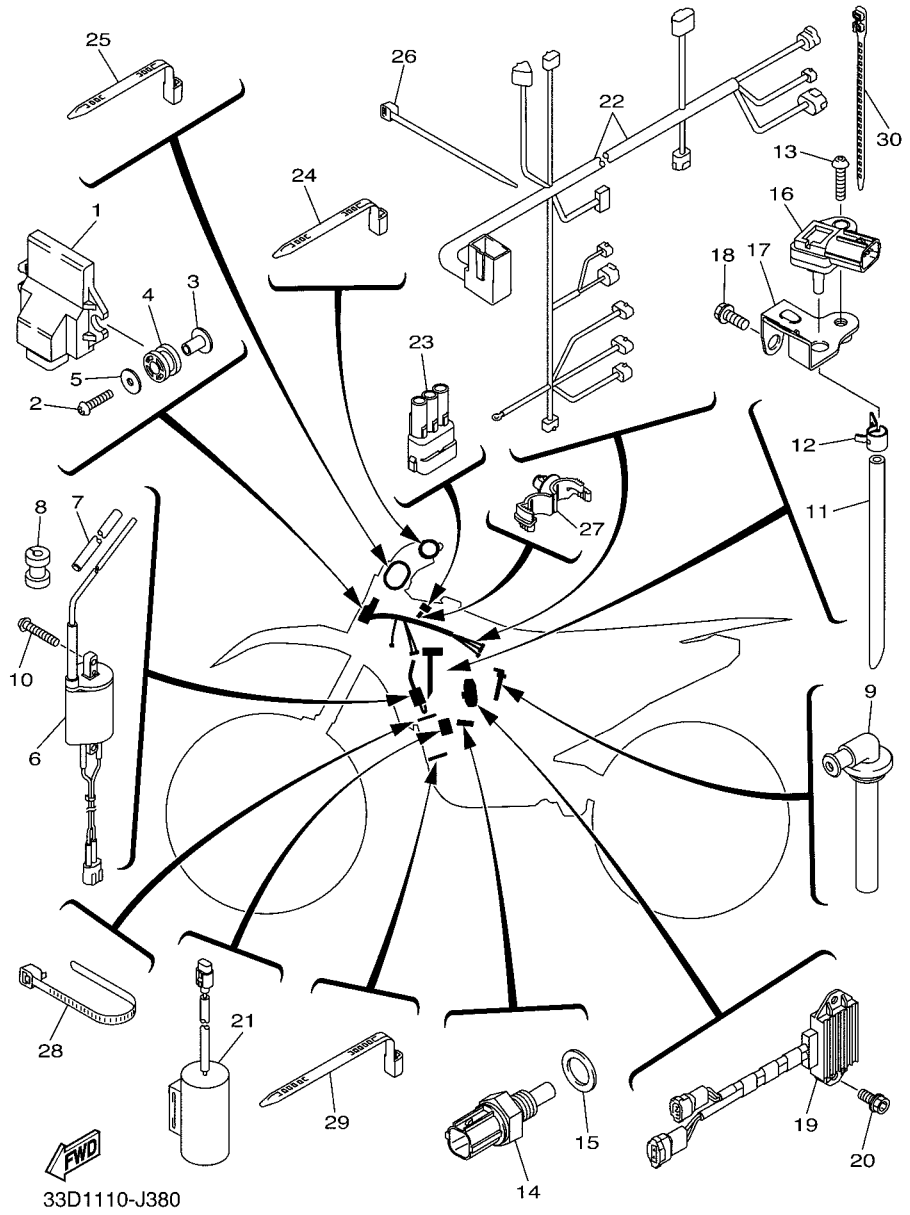
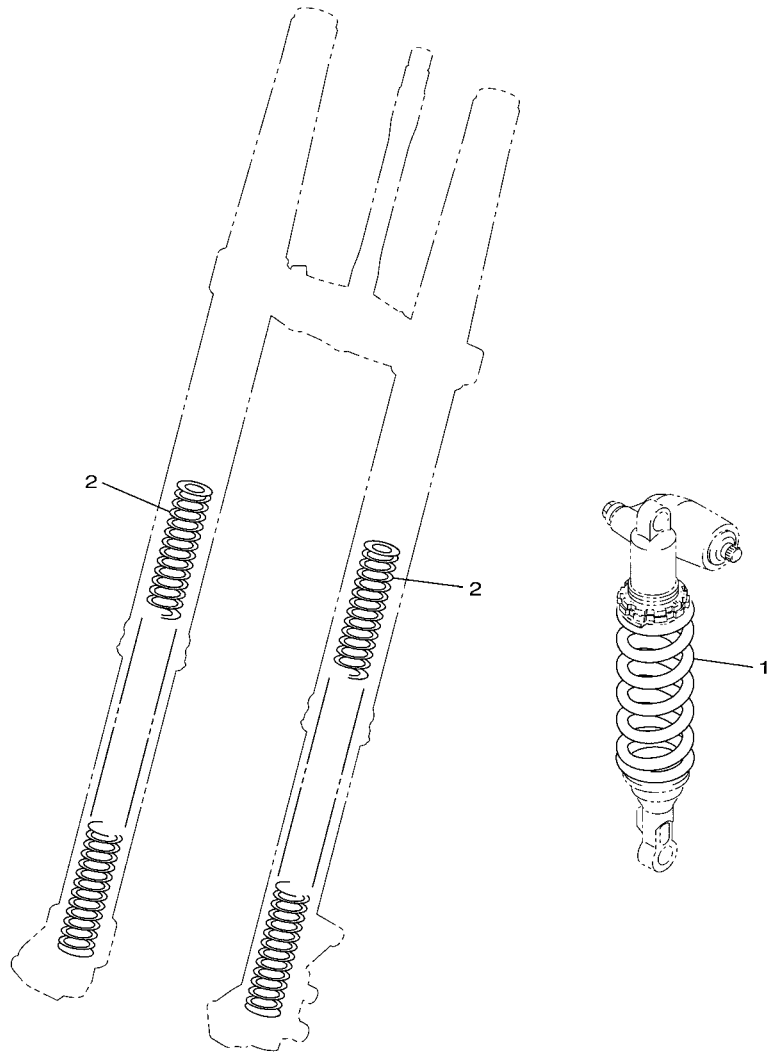

FIG. 38 ELECTRICAL 1

REF. NO.	PART NO.	DESCRIPTION	33DD				REMARKS
28	90464-20258	CLAMP	1				
29	90464-15195	CLAMP	1				
30	90464-45001	CLAMP	1				





33D1110-J390

FIG. 39 ALTERNATE FOR CHASSIS

REF. NO.	PART NO.	DESCRIPTION	33DD			REMARKS
1	33D-22212-10	SPRING (K=52N/MM)	1			AP BLUE
	33D-22212-20	SPRING (K=54N/MM)	1			AP BLUE
	33D-22212-40	SPRING (K=58N/MM)	1			AP BLUE
	33D-22212-B0	SPRING (K=52N/MM)	1			AP RED
	33D-22212-C0	SPRING (K=54N/MM)	1			AP RED
	33D-22212-E0	SPRING (K=58N/MM)	1			AP RED
2	33D-23141-20	SPRING, FRONT FORK(K=4.5N/MM)	2			AP
	33D-23141-30	SPRING, FRONT FORK(K=4.6N/MM)	2			AP
	33D-23141-40	SPRING, FRONT FORK(K=4.7N/MM)	2			AP

NUMERICAL INDEX

PART NO.	REF. NO.	PART NO.	REF. NO.	PART NO.	REF. NO.	PART NO.	REF. NO.	PART NO.	REF. NO.	PART NO.	REF. NO.
33D-11102-00	1 - 1	3LD-12168-R1	3 - 11	5D3-13440-01	8 - 1	2S2-1469E-00	11 - 18	2S2-17141-00	16 - 7	3RV-21668-A0	22 - 32
5PS-11133-10	1 - 2	3LD-12168-U1	3 - 11	33D-13447-00	8 - 2	2S2-1469F-00	11 - 19	2S2-17151-00	16 - 3	33D-21710-01	21 - 1
5PS-11134-10	1 - 3	3LD-12168-W1	3 - 11	33D-13542-00	38 - 11	5PH-14714-00	11 - 5	2S2-17211-00	16 - 14	33D-21719-00	21 - 12
33D-11166-00	1 - 23	3LD-12168-Y1	3 - 11	33D-13577-00	10 - 7	8GL-14714-00	11 - 20	2S2-17221-00	16 - 25	5XC-21719-90	21 - 11
371-11167-01	1 - 22	3LD-12169-11	3 - 11	33D-13597-00	9 - 1	2D1-14737-00	11 - 6	2S2-17231-00	16 - 20	33D-21720-01	21 - 8
33D-11181-00	1 - 14	3LD-12169-31	3 - 11	33D-13750-00	10 - 1	5VY-14747-00	11 - 11	2S2-17241-00	16 - 23	33D-2172A-00	21 - 34
33D-11191-10	1 - 19	3LD-12169-50	3 - 11	3B4-13761-00	10 - 11	33D-14750-10	11 - 13	33D-17251-00	16 - 17	33D-2172P-00	21 - 5
33D-11193-01	1 - 21	3LD-12169-70	3 - 11	33D-13907-00	26 - 15	33D-1476F-10	11 - 14	33D-17402-00	16 - 13	33D-2172S-00	21 - 4
33D-1119E-00	1 - 26	3LD-12169-90	3 - 11	33D-13938-00	10 - 2	33D-14788-00	11 - 7	2S2-17411-00	16 - 2	33D-21730-01	21 - 22
5UM-1119E-00	1 - 25	3LD-12169-E0	3 - 11	33D-13971-00	26 - 21	8GL-14789-00	11 - 22	2S2-17466-00	12 - 10	33D-21730-51	21 - 22
33D-11311-10	1 - 27	3LD-12169-G0	3 - 11	3TJ-14137-40	9 - 7	33D-14987-00	9 - 6	33D-17471-00	16 - 34	33D-2173E-50	9 - 44
33D-11351-00	1 - 28	3LD-12169-J0	3 - 11		10 - 10	33D-15100-09	12 - 1	33D-18101-00	18 - 2	33D-2173E-60	9 - 44
33D-11400-01	2 - 1	3LD-12169-L0	3 - 11	5PS-14147-00	10 - 12	5XC-15118-00	12 - 24	2S2-18110-00	18 - 8	33D-2173F-50	9 - 45
33D-11412-00	2 - 2	3LD-12169-N0	3 - 11	33D-14171-00	10 - 4	17D-15155-00	12 - 3	18P-18122-00	18 - 3	33D-2173G-60	9 - 45
33D-11422-00	2 - 3	3LD-12169-T0	3 - 11	33D-14216-00	10 - 9	3Y1-15361-00	12 - 23	33D-18140-00	17 - 4	33D-2173P-00	21 - 17
33D-11454-00	2 - 14	33D-12170-00	4 - 1	33D-14227-00	9 - 5	3Y1-15363-10	13 - 6	5TJ-18172-00	18 - 16	33D-2173S-00	21 - 15
33D-11455-00	2 - 9	33D-12180-00	4 - 2	33D-14293-00	9 - 4	2S2-15378-00	13 - 13	3XJ-18173-10	18 - 11	33D-21740-01	21 - 27
33D-11464-00	2 - 16	5TA-12210-30	4 - 5	33D-14325-00	10 - 5	4JT-15381-01	12 - 15	33D-18175-00	17 - 7	33D-21740-51	21 - 27
2S2-11531-00	2 - 11	4FM-12213-00	4 - 8	33D-14348-00	10 - 6	18P-15383-00	12 - 16	3XJ-18178-00	18 - 12	5PA-21748-00	21 - 23
33D-11536-00	2 - 8	5EL-12214-00	4 - 7	33D-14417-00	9 - 17	2S2-15388-00	12 - 19	3XJ-18182-00	18 - 13		21 - 28
33D-11603-00	2 - 23	5EL-12228-00	4 - 6	5TJ-14419-00	9 - 24	33D-15411-00	13 - 1	3XJ-18184-00	18 - 15	17D-21749-00	21 - 2
33D-11631-00	2 - 22	33D-12233-00	4 - 13	33D-1441B-00	9 - 27	33D-15415-10	13 - 22	1C3-18185-00	18 - 1		21 - 9
33D-11633-00	2 - 24	5BE-12241-00	1 - 20	33D-1441G-00	9 - 16	33D-15421-00	12 - 9	33D-18501-10	17 - 8		21 - 24
33D-11651-00	2 - 6	33D-12251-00	4 - 11	33D-14425-00	9 - 35	33D-15431-00	13 - 14	33D-18502-10	17 - 9		21 - 29
5TG-11681-01	2 - 4	33D-12252-00	4 - 12		9 - 40	33D-15441-10	12 - 28	5TG-18503-00	17 - 10	5BE-21749-00	21 - 3
33D-116A0-00	2 - 21	33D-1240A-00	6 - 7	33D-14428-00	9 - 8	33D-15451-00	13 - 8	33D-18541-10	17 - 1		21 - 10
33D-12111-00	3 - 1	33D-12422-00	5 - 7	33D-14437-00	9 - 33	33D-15453-00	13 - 23	33D-18562-00	12 - 20	5XC-21749-90	26 - 30
33D-12113-00	3 - 5	33D-12427-00	5 - 8	33D-14437-10	9 - 33	33D-15462-00	13 - 18	33D-21101-90	19 - 1		26 - 33
33D-12114-00	3 - 6	33D-12446-00	6 - 1	33D-1443A-00	9 - 38	2S2-15601-00	14 - 1	33D-21163-00	19 - 43	33D-2174A-00	21 - 13
33D-12116-00	3 - 3	5DJ-12451-00	5 - 2	33D-1443A-10	9 - 38	33D-15620-01	14 - 18	33D-2116J-00	19 - 47	33D-2174G-40	21 - 7
33D-12117-00	3 - 7	5GR-12458-00	5 - 1	33D-1443E-00	9 - 25	33D-15621-01	14 - 19	33D-2116M-00	19 - 41	33D-2174G-50	21 - 7
3LD-12117-00	3 - 8	33D-12461-00	6 - 8	33D-14449-00	9 - 20	5TA-15651-00	14 - 15	33D-2117F-00	19 - 13	33D-2174H-40	21 - 19
3LD-12118-00	3 - 9	5SL-12462-00	6 - 9	33D-14451-00	9 - 29	5GR-15664-00	14 - 8	5PA-2118K-00	20 - 12	33D-2174H-50	21 - 19
51Y-12119-00	3 - 10	33D-12465-00	6 - 10	33D-14454-00	9 - 10	2NX-15668-00	14 - 12	33D-21190-00	19 - 5	33D-2174P-00	21 - 6
33D-12121-00	3 - 2	33D-12482-00	6 - 4	33D-14458-00	9 - 30	2S2-15671-00	14 - 4	33D-21268-00	19 - 50	33D-2174S-00	21 - 16
33D-12126-00	3 - 4	5Y9-12491-00	38 - 26	33D-14459-00	9 - 13	3Y6-15674-00	14 - 11	33D-21417-00	19 - 27	33D-2174T-00	21 - 14
4C8-12153-10	3 - 12	5BE-12564-00	5 - 13	33D-14461-00	9 - 28	2S2-16111-60	15 - 1	33D-21425-00	19 - 34	33D-2175P-00	21 - 18
5EB-12153-10	3 - 13	33D-12576-00	6 - 13	33D-14462-00	9 - 12	5XD-16150-60	15 - 4	33D-21426-00	19 - 35	33D-2194U-00	19 - 45
3LD-12168-00	3 - 11	33D-12577-00	6 - 14	33D-14477-00	9 - 11	5XD-16154-00	15 - 11	5YU-2143A-00	24 - 15	33D-22110-00	22 - 1
3LD-12168-20	3 - 11	33D-12578-00	6 - 15	33D-14480-00	9 - 31	5TA-16321-00	15 - 8	17D-21447-00	19 - 2	5XC-22121-91	22 - 28
3LD-12168-40	3 - 11	33D-12579-00	6 - 16	33D-14486-00	10 - 3	4B1-16324-00	15 - 7	17D-21448-00	19 - 3	34P-22122-00	22 - 29
3LD-12168-60	3 - 11	5B3-13113-00	13 - 27	33D-14495-00	9 - 19	2S2-16351-00	15 - 6	5XC-21456-90	19 - 29	2S2-22128-70	22 - 11
3LD-12168-80	3 - 11	2S2-13300-10	7 - 1	33D-14562-00	10 - 8	33D-16356-00	15 - 14	33D-21471-00	19 - 37	33D-22141-00	22 - 15
3LD-12168-A0	3 - 11	5TA-13320-00	7 - 2	33D-14611-00	11 - 1	2S2-16357-00	15 - 18	33D-2147E-00	19 - 39	34P-22151-01	22 - 8
3LD-12168-F0	3 - 11	2S2-13341-00	7 - 9	33D-14613-00	11 - 2	5TA-16371-10	15 - 5	17D-21511-50	20 - 1	5UN-22176-00	23 - 15
3LD-12168-H1	3 - 11	2S2-13342-00	7 - 7	33D-14620-00	11 - 4	33D-16381-10	15 - 19	17D-21511-60	20 - 1	30X-22178-00	19 - 8
3LD-12168-K1	3 - 11	5BE-13411-00	7 - 13	33D-1466G-10	11 - 16	2S2-17121-00	16 - 9	33D-21610-10	20 - 6	3JD-22178-20	19 - 18
3LD-12168-M1	3 - 11	2S2-13412-00	7 - 12	2S2-1469A-10	11 - 17	33D-17131-00	16 - 6	33D-21642-00	20 - 9	17D-2217A-00	22 - 18

NUMERICAL INDEX

PART NO.	REF. NO.	PART NO.	REF. NO.	PART NO.	REF. NO.	PART NO.	REF. NO.	PART NO.	REF. NO.	PART NO.	REF. NO.
33D-2217F-00	22 - 24	1C3-23142-L0	25 - 37	33D-23472-00	24 - 19	5SF-25394-00	28 - 11	1UY-25937-51	29 - 14	5XC-83922-L0	33 - 12
4V4-22184-00	19 - 9	5XE-23144-L0	25 - 10	17D-23485-50	24 - 17	17D-25447-50	30 - 6		31 - 18	33D-83976-01	37 - 11
5MV-22184-00	23 - 16		25 - 34	33D-24106-10	26 - 28	17D-25448-50	30 - 6	17D-26111-H0	32 - 1	5LP-84126-10	37 - 4
2S2-22199-70	22 - 10	17D-23145-00	25 - 8	33D-24106-50	26 - 28	17D-25449-50	30 - 6	17D-26124-00	32 - 14	33D-85885-00	10 - 14
33D-22200-80	23 - 1		25 - 32	33D-24108-10	26 - 31	17D-25450-50	30 - 6	17D-26143-H0	32 - 15	8FP-85886-00	9 - 22
33D-22200-C0	23 - 1	5XC-23146-10	25 - 7	33D-24108-50	26 - 31	17D-25451-50	30 - 6	5TJ-26240-C0	32 - 3	33D-8591A-70	38 - 1
33D-22201-40	23 - 2		25 - 31	33D-24110-50	26 - 1	17D-25452-50	30 - 6	4GY-26241-00	32 - 2	5XC-W0041-00	33 - 5
33D-22212-10	39 - 1	1AE-23147-00	25 - 19	3C5-2411B-20	20 - 11	5CG-25715-00	33 - 9	4GY-26242-00	32 - 4	5UN-W0042-50	35 - 2
33D-22212-20	39 - 1		25 - 43	4EW-2412F-00	26 - 23		35 - 9	3Y1-26249-00	32 - 5	5XC-W0045-00	29 - 8
33D-22212-30	23 - 9	1C3-23147-L0	25 - 12	33D-24135-00	26 - 22	17D-25718-50	31 - 20	5BE-26281-01	32 - 6	1C3-W0046-50	31 - 9
33D-22212-40	39 - 1		25 - 36	5PW-2413B-00	21 - 26	5XC-2580T-G0	29 - 3	5BE-26282-00	32 - 7	5KM-W0047-10	29 - 5
33D-22212-B0	39 - 1	17D-23153-00	25 - 3		21 - 31	17D-2580W-01	31 - 3	5SF-26287-11	32 - 9	5UN-W0047-50	31 - 5
33D-22212-C0	39 - 1		25 - 27	33D-24144-00	26 - 6	5XC-2581T-G0	29 - 1	33D-26302-00	32 - 10	1UY-W0048-50	29 - 7
33D-22212-D0	39 - 9	5XE-23153-L0	25 - 9	3FB-2415E-02	20 - 5	1UY-25824-51	31 - 7	33D-26335-00	32 - 11	5XC-W0057-00	29 - 4
33D-22212-E0	39 - 1		25 - 33	33D-24181-00	19 - 56	1UY-25825-51	31 - 8	17D-26337-00	37 - 5	5UN-W0057-50	31 - 4
33D-22213-00	23 - 7	2HH-23158-L0	25 - 23	33D-24182-00	19 - 57	5UN-25827-60	31 - 11	34P-26342-00	32 - 12	5XC-W2587-00	33 - 4
33D-22214-00	23 - 10		25 - 47	33D-24183-00	19 - 58	5UN-25828-60	31 - 10	34P-26372-00	37 - 8	90101-05005	37 - 7
33D-22224-00	23 - 11	17D-2315H-50	25 - 52	33D-24192-00	26 - 18	2S2-2582W-70	31 - 1	5XC-26372-G0	33 - 17	90101-06041	18 - 17
4JX-22226-00	23 - 4	17D-2315H-H0	25 - 52	33D-2419A-00	26 - 10	5MV-25833-00	33 - 16	33D-27200-01	34 - 1	90101-06044	14 - 13
33D-22234-00	23 - 6	17D-2315J-50	25 - 51	33D-24217-00	26 - 25	33D-2583V-00	35 - 1	17D-27217-00	34 - 2	90101-08006	30 - 22
5NY-22241-00	23 - 22	17D-2315J-H0	25 - 51	3XJ-24380-00	26 - 4	5XC-25849-G0	29 - 15	5UN-27217-00	35 - 8	90105-05028	9 - 32
5XE-22242-00	23 - 19	33D-2316A-20	25 - 14	33D-24486-00	26 - 16	5UN-25852-50	35 - 5	5UN-27218-00	35 - 3	90105-06027	1 - 4
1C3-22253-50	23 - 12		25 - 38	33D-24491-00	26 - 17	5XC-25852-G0	33 - 7	5UN-27222-00	35 - 4	90105-06064	21 - 32
1C3-22253-L1	23 - 17	33D-23170-20	25 - 11	5NY-24610-10	26 - 2	5XC-25853-G0	33 - 10	34P-27311-00	34 - 16		24 - 18
4AA-22259-80	23 - 8		25 - 35	18P-2464V-00	19 - 54	5UN-25854-00	35 - 7	17D-27411-00	34 - 9		26 - 34
4EW-22474-00	23 - 14	5XE-23171-L0	25 - 5	33D-24665-00	26 - 26	5XC-25854-G0	33 - 6	17D-27421-00	34 - 10	90105-06081	12 - 21
3JE-22475-00	23 - 13		25 - 29	18P-2467E-00	19 - 53	5UN-2585B-00	35 - 6	17D-27491-50	31 - 22		16 - 35
5NY-22475-00	23 - 18	5DH-23183-00	23 - 5	33D-2470F-50	27 - 2	5CG-2585G-00	33 - 11	17D-2812P-00	20 - 13	90105-06091	7 - 14
5UN-22898-60	31 - 12	509-23184-L0	23 - 3	33D-2470F-A0	27 - 2		35 - 10	33D-2814A-00	19 - 55	90105-06099	4 - 14
1C3-22969-90	22 - 9	1C3-23188-L0	25 - 15	33D-24710-90	27 - 1	5MV-25867-00	33 - 15	5TA-2814F-00	19 - 52		12 - 29
33D-23102-20	25 - 1		25 - 39	33D-24710-A0	27 - 1	17D-25872-50	33 - 1	5ET-28166-10	19 - 51	90105-06100	20 - 7
33D-23103-20	25 - 25	1C3-23188-N0	25 - 16	5NY-25104-00	28 - 7	5XC-25873-L0	35 - 12	33D-81410-00	36 - 1	90105-06104	22 - 12
33D-23110-10	25 - 28		25 - 40	5NY-25111-00	28 - 1	1C3-25876-50	35 - 17	33D-81450-00	36 - 2	90105-06105	22 - 14
5XC-23111-00	25 - 22	1C3-23188-P0	25 - 17	5NY-25117-00	28 - 3	1C3-25886-50	35 - 15	33D-81528-00	36 - 3	90105-06107	31 - 23
	25 - 46		25 - 41	5XC-25181-G0	28 - 12	5MV-2589F-00	33 - 13	33D-81960-00	38 - 19	90105-06110	31 - 21
276-23114-00	25 - 24	1C3-23188-R0	25 - 18	5XC-25183-G0	28 - 13	5UN-25913-00	31 - 19	33D-81965-00	38 - 21		38 - 18
	25 - 48		25 - 42	5XC-25186-G0	28 - 14	5UN-25914-00	31 - 17	33D-82310-00	38 - 6		38 - 20
33D-23120-10	25 - 4	1C3-23190-L0	25 - 20	34P-25304-00	30 - 10	5DH-25914-50	31 - 15	33D-82351-00	38 - 7	90105-06111	6 - 23
5XE-23125-L0	25 - 6		25 - 44	17D-2530S-00	30 - 19	3SP-25914-51	29 - 12	33D-82370-00	38 - 9		31 - 24
	25 - 30	33D-23340-00	25 - 49	17D-25311-00	30 - 1	5DH-25916-00	29 - 10	33D-82378-00	38 - 23	90105-06127	18 - 9
33D-23136-00	25 - 2	17D-23389-50	24 - 2	17D-25317-00	30 - 2		31 - 14	2C0-82380-00	10 - 15		20 - 3
	25 - 26	17D-2339R-00	24 - 20	17D-2531B-00	28 - 6	3JD-25917-00	29 - 13		38 - 16	90105-06156	31 - 2
33D-23141-20	39 - 2	17D-23416-50	24 - 6		30 - 12		31 - 16	33D-82388-00	38 - 17	90105-06170	9 - 43
33D-23141-30	39 - 2	33D-23435-00	24 - 9	4XM-25364-00	30 - 17	5DH-25919-00	29 - 6	33D-82590-00	38 - 22		19 - 46
33D-23141-40	39 - 2	18P-23441-00	24 - 11	17D-25381-00	30 - 24	5DH-25919-50	31 - 6	17D-82911-00	37 - 1		20 - 8
33D-23141-D0	25 - 21	33D-23442-00	24 - 12	17D-25388-00	30 - 20	8CR-25924-00	31 - 13	33D-82913-00	37 - 9		21 - 20
	25 - 45	17D-23466-00	25 - 54	33D-25389-00	30 - 21	3SP-25926-51	29 - 11	4P9-83591-00	38 - 14		24 - 3
1C3-23142-L0	25 - 13	17D-23467-00	25 - 55	3JE-25394-00	30 - 16	5DH-25933-00	29 - 9	17D-83912-00	37 - 2		25 - 56

NUMERICAL INDEX

PART NO.	REF. NO.	PART NO.	REF. NO.	PART NO.	REF. NO.	PART NO.	REF. NO.	PART NO.	REF. NO.	PART NO.	REF. NO.
90105-06179	21 - 33	90159-06027	17 - 6	90201-21014	22 - 23	90387-225N2	32 - 13	90501-230E4	15 - 9	93306-00426	16 - 12
90105-06189	12 - 11	90170-10405	2 - 18	90201-22023	30 - 26	90387-2513F	16 - 29	90506-18019	34 - 5	93306-00447	16 - 11
90105-08137	11 - 9	90170-14171	2 - 12	90201-253K0	16 - 4	90387-28012	16 - 26	90508-26021	17 - 5	93306-20532	16 - 1
	29 - 16	90170-20255	15 - 3		16 - 21	90401-10172	33 - 3	90508-28015	34 - 11	93306-205A5	16 - 27
90105-08143	19 - 28		15 - 13	90201-286K9	24 - 8		35 - 13	90508-28018	34 - 12	93306-30633	2 - 7
90105-08154	24 - 16	90179-06055	9 - 34	90208-20008	15 - 2	90430-06014	1 - 11	90508-29021	18 - 5	93306-80502	17 - 3
	25 - 50		9 - 39		15 - 12		4 - 10	90508-305B0	14 - 9	93306-90409	17 - 2
90105-08226	19 - 36	90179-08019	30 - 23	90209-16011	22 - 22		5 - 12	91312-06020	9 - 2		28 - 2
90105-08230	19 - 7	90179-10658	19 - 25	90209-21332	16 - 10		12 - 27	91312-06030	7 - 6	93306-90510	30 - 3
90105-08231	19 - 6		19 - 31	90209-22008	16 - 19		13 - 12	91402-20012	34 - 8	93310-63458	2 - 5
90105-08232	19 - 21	90179-12657	36 - 6	90209-26348	16 - 24	90430-08002	12 - 12	91402-25015	34 - 15	93315-32166	22 - 19
90105-10176	19 - 30	90179-16011	28 - 15	90215-10009	2 - 19	90430-08119	1 - 9	91808-16023	1 - 6		22 - 25
90105-10189	19 - 33	90179-20001	16 - 33	90215-14287	2 - 13		12 - 14		1 - 7	93317-11287	15 - 20
90105-10193	19 - 24	90179-24004	24 - 10	90215-21003	16 - 32	90430-09002	10 - 13	91812-16001	13 - 19	93317-22262	22 - 2
90105-10367	1 - 16	90179-28015	24 - 7	90240-08120	34 - 6	90430-10004	38 - 15	91A20-05065	6 - 11	93332-00068	24 - 5
90109-06034	37 - 3	90185-08008	30 - 8	90240-10004	34 - 13	90430-10005	33 - 2	92012-05010	19 - 44	93332-00081	24 - 1
90109-06232	25 - 53	90185-08009	19 - 22	90267-48084	11 - 15		35 - 14	92012-05016	38 - 10	93340-21209	15 - 15
90109-08078	30 - 7	90185-10012	23 - 23	90269-07001	26 - 27	90445-09003	26 - 3		38 - 13	93342-22217	22 - 3
90110-05058	26 - 20	90185-14010	22 - 31	90280-03006	2 - 20	90445-09005	26 - 5	92012-05025	38 - 2	93410-20038	14 - 3
90110-05062	12 - 5	90185-16002	22 - 16	90282-05034	2 - 17	90450-22001	6 - 19	92902-10200	23 - 21	93440-10085	15 - 16
90110-06161	36 - 5	90185-22011	30 - 25	90340-12007	1 - 5	90450-25001	6 - 18		24 - 13	93440-10153	7 - 4
90110-06245	9 - 37	90201-04030	9 - 15	90340-14011	13 - 4	90450-28001	6 - 17	93101-14164	13 - 15	93440-25084	16 - 5
	9 - 42	90201-05043	38 - 5	90340-36002	13 - 2	90450-32003	6 - 20	93102-12106	5 - 5		16 - 18
90110-06362	12 - 6	90201-05N15	19 - 15	90387-05003	19 - 16	90450-58007	9 - 9	93102-12224	15 - 21	93440-28062	16 - 22
90110-06363	12 - 7	90201-06108	20 - 4	90387-05048	38 - 3	90450-60004	9 - 3		18 - 10	93440-41178	4 - 3
90110-06364	12 - 8	90201-06571	6 - 24	90387-06009	9 - 18	90464-13073	38 - 25	93102-20108	14 - 14	93450-19052	2 - 25
90110-08087	14 - 24	90201-08043	19 - 23		9 - 36	90464-13077	38 - 24	93102-26468	28 - 4	93503-08007	13 - 28
90111-04008	9 - 14	90201-08044	34 - 7		9 - 41	90464-15195	38 - 29	93102-32337	30 - 4	93507-32009	14 - 21
90111-06007	26 - 9	90201-08045	19 - 10		26 - 29	90464-18002	38 - 27	93102-32480	16 - 28	93511-32027	15 - 17
	26 - 11	90201-08047	14 - 25		26 - 32	90464-20258	38 - 28	93106-22002	22 - 4	93603-16219	7 - 3
90111-06116	35 - 11	90201-08048	30 - 9	90387-06065	6 - 22	90464-31002	19 - 49	93109-11073	5 - 4	93604-10011	5 - 9
90116-06037	1 - 12	90201-08061	11 - 10	90387-06091	26 - 7	90464-45001	38 - 30	93109-21001	22 - 26	93608-33002	18 - 7
90119-06146	19 - 40	90201-08512	5 - 3	90387-06105	24 - 4	90467-07138	38 - 12	93109-25001	22 - 20	93612-16254	1 - 15
90119-06149	19 - 38	90201-10025	1 - 17	90387-06133	21 - 25	90467-090A2	6 - 12	93109-28043	22 - 5	9383E-13233	16 - 31
90119-06239	6 - 25	90201-10032	34 - 14		21 - 30	90467-140A4	1 - 24	93210-07001	12 - 4	94108-21028	28 - 8
90119-08095	21 - 21	90201-10045	19 - 26	90387-06236	26 - 13	90467-16098	9 - 26	93210-11073	34 - 3	94112-19009	30 - 13
90119-08133	11 - 21		19 - 32	90387-06259	20 - 2	90468-16001	34 - 4	93210-14369	13 - 5	94211-19273	30 - 14
90149-05031	36 - 4	90201-12166	7 - 11	90387-08041	19 - 11	90480-01023	26 - 14	93210-16500	6 - 6	94227-21101	28 - 9
90149-06069	7 - 8	90201-127E1	18 - 6	90387-08081	11 - 12	90480-08608	30 - 18	93210-17570	14 - 23	94309-21161	28 - 10
90149-06074	12 - 18		36 - 7	90387-086N4	19 - 20	90480-11015	38 - 8	93210-19123	13 - 7	94311-19155	30 - 15
90149-06083	2 - 15	90201-14020	22 - 30	90387-124F4	18 - 4	90480-12025	19 - 17	93210-19758	5 - 14	94416-21045	28 - 5
90149-10031	19 - 4	90201-15701	13 - 16	90387-14016	22 - 27	90480-13029	38 - 4	93210-22164	16 - 30	94421-19013	30 - 11
90151-06032	19 - 42	90201-16018	22 - 17	90387-16026	22 - 21	90480-15012	6 - 21	93210-24253	6 - 2	94591-57122	4 - 4
90151-06045	14 - 22	90201-162H4	14 - 10	90387-17015	12 - 22	90480-18549	26 - 8	93210-357A3	13 - 3	94682-28001	30 - 28
90151-06051	29 - 2	90201-167P7	14 - 6	90387-17016	22 - 6	90501-043E0	13 - 29	93210-45708	8 - 3	94701-00410	1 - 13
90151-08003	12 - 17	90201-203E7	16 - 16	90387-1714S	22 - 7	90501-052G5	18 - 14	93300-60839	19 - 19	94701-00411	1 - 13
90154-05012	26 - 19	90201-20685	14 - 2	90387-20028	16 - 15	90501-147A5	14 - 20	93304-20310	2 - 10	95022-06010	1 - 10
90159-06010	15 - 10		14 - 16	90387-21005	16 - 8	90501-160A2	14 - 5	93306-00105	5 - 6		5 - 11

NUMERICAL INDEX

PART NO.	REF. NO.	PART NO.	REF. NO.	PART NO.	REF. NO.	PART NO.	REF. NO.	PART NO.	REF. NO.
95022-06010	19 - 48	99530-10114	7 - 15						
95022-06012	6 - 5	99530-14016	1 - 29						
	12 - 25		12 - 2						
	12 - 26	9Y582-28113	30 - 27						
95022-06016	8 - 4								
95022-06020	6 - 3								
	37 - 10								
95022-06025	4 - 9								
	5 - 10								
	13 - 24								
	26 - 12								
95022-06030	13 - 11								
	13 - 21								
95022-06035	1 - 18								
	1 - 30								
95022-06040	13 - 10								
	13 - 20								
95022-06070	8 - 5								
	13 - 25								
95022-06080	13 - 26								
95022-08012	1 - 8								
95022-08040	19 - 12								
95024-08025	11 - 23								
95024-08035	11 - 8								
95302-05600	37 - 6								
95602-10200	23 - 20								
	24 - 14								
95701-06500	33 - 14								
95702-06500	22 - 13								
95704-06500	11 - 3								
95822-08016	12 - 13								
97702-50516	9 - 21								
	9 - 23								
97702-60016	20 - 10								
98502-05010	35 - 16								
	35 - 18								
98502-05016	19 - 14								
98507-05020	32 - 8								
98702-06025	26 - 24								
98706-04012	33 - 8								
99009-12400	7 - 10								
99009-16400	14 - 7								
99009-20400	14 - 17								
99009-20500	15 - 22								
99009-22500	13 - 17								
99009-42700	30 - 5								
99530-08012	7 - 5								
99530-08016	13 - 9								