

PARTS CATALOGUE

YZ125E2 (1SR9) CANADA

YZ125 (1SRA) EUROPE

YZ125 (1SRB) JAPAN

YZ125E2 (1SRC) AUSTRALIA, NEW ZEALAND

YZ125 (1SRC) SOUTH AFRICA

YZ125/YZ125E2
PARTS CATALOGUE
©2013 by Yamaha Motor Co., Ltd.
1st edition, April 2013
All rights reserved.
Any reprinting or unauthorized use
without the written permission of
Yamaha Motor Co., Ltd.
is expressly prohibited.
Printed in Japan.

FOREWORD

This Parts Catalogue is related to the parts for the model(s) on the cover page. When you are ordering replacement parts, please refer to this Parts Catalogue and quote both part numbers and part names correctly.

1. Modifications or additions which have been made after the issue of the Parts Catalogue will be announced in the Parts News.

It is advisable that you make the necessary corrections to the Parts Catalogue according to the Parts News.

2. Abbreviations

The following abbreviations are used in this Parts Catalogue.

“UR” Use specified parts number.

“UN” Use as many as needed.

“AP” Alternate Parts

“LM” Locally Made (Parts need to be ordered locally)

“F#” Frame No. (Applicable machine No.)

“O/S” Over Size

3. The number of components for assembly

- Parts, which are to be supplied in an assembly, are listed with a dot (.) in front of the part name as shown below.
- The numeral appearing to the right of each component part indicates the quantity of parts for each assembly unit.

PART NO.	DESCRIPTION	Q'TY	REMARKS
2F5-83310-60	FRONT FLASHER LIGHT ASSY	2	
115-83311-60	.BULB (6V-18W)	1	

4. Applicable colours of graphics are represented in the “REMARKS” as shown below.

PART NO.	DESCRIPTION	Q'TY	REMARKS
2N4-24110-00-X5	FUEL TANK COMP.	2	MXR
3J1-24240-10	.GRAPHIC, FUEL TANK	1	FOR MXR

5. Note that the illustrations for reference in finding parts numbers are not to be used for assembling. When assembling, please use the applicable service manual.

6. The asterisk (*) before a reference number indicates modified items after the first edition.

FOREWORD

7. Applicable Serial No.

Engine Serial No.

Frame Serial No.

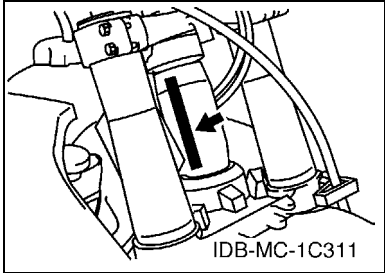
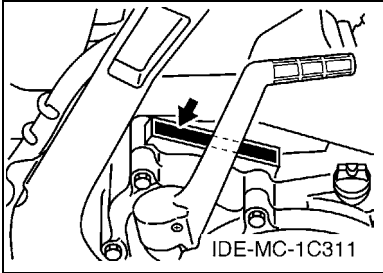

8. Applicable Colour Code (The (*) mark shows Model colour.)

Abbreviation	Colour Name	Colour Code
DPBSE(*)	DEEP PURPLISH BLUE SOLID E	0583

MODEL LABEL

(1) A label called "Model Label" is affixed in the location as indicated in (3) below. When using this parts catalogue, please be sure to cross-reference the "model code – production code No." in the catalogue with the "model code – production code No." indicated on the Model Label affixed onto the product concerned.

(2) "Model Label" Indication

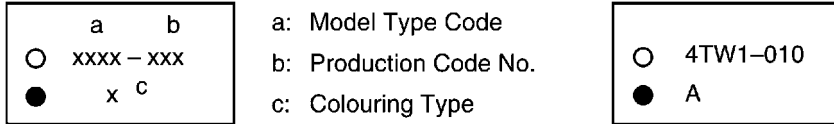

(3) Model Label Affixing Location

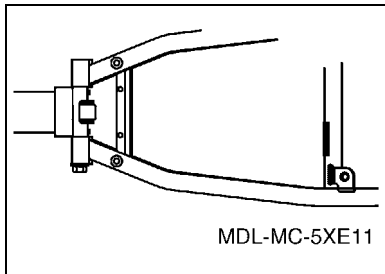

(4) Colouring Information

Model Code	Colouring Type Code	Colour Code	Colour Name	Abbreviation
1SR9	A	0583	DEEP PURPLISH BLUE SOLID E	DPBSE
1SRA	A	0583	DEEP PURPLISH BLUE SOLID E	DPBSE
1SRB	A	0583	DEEP PURPLISH BLUE SOLID E	DPBSE
1SRC	A	0583	DEEP PURPLISH BLUE SOLID E	DPBSE

(5) Model Code – Production Code Number of Model Listed in This Parts Catalogue

Model Code	Production Code No.	Country (destination)	Model Code	Production Code No.	Country (destination)
1SR9	020	CANADA	1SRC	010	AUSTRALIA
1SRA	010	AUSTRIA			NEW ZEALAND
		BELGIUM	020	SOUTH AFRICA	
		CYPRUS			
		CZECHO			
		DENMARK			
		FINLAND			
		FRANCE			
		GERMANY			
		GREECE			
		HUNGARY			
		IRELAND			
		ITALY			
		NETHERLANDS			
		NORWAY			
		POLAND			
		PORTUGAL			
SLOVAK					
SLOVENIA					
SPAIN					
SWEDEN					
SWITZERLAND					
TURKEY					
UNITED KINGDOM					
1SRB	010	JAPAN			

CONTENTS

ENGINE

CYLINDER HEAD	1
GOVERNOR	3
CRANKSHAFT & PISTON	4
WATER PUMP	5
RADIATOR & HOSE	6
INTAKE	7
CARBURETOR	8
EXHAUST	11
CRANKCASE	12
CRANKCASE COVER 1	13
STARTER	14
CLUTCH	15
TRANSMISSION	16
SHIFT CAM & FORK	18
SHIFT SHAFT	19

CHASSIS

FRAME	20
FENDER	22
SIDE COVER	23
REAR ARM	24
REAR SUSPENSION	26
STEERING	28
FRONT FORK	29
FUEL TANK	32
SEAT	34
FRONT WHEEL	35
FRONT BRAKE CALIPER	36
REAR WHEEL	37
REAR BRAKE CALIPER	39
STEERING HANDLE & CABLE	40
FRONT MASTER CYLINDER	41
STAND & FOOTREST	42
REAR MASTER CYLINDER	43
GENERATOR	44
HANDLE SWITCH & LEVER	45
ELECTRICAL 1	46
ALTERNATE FOR CHASSIS	47
OPTIONAL PARTS 1	48

INDEX

NUMERICAL INDEX	49
-----------------------	----

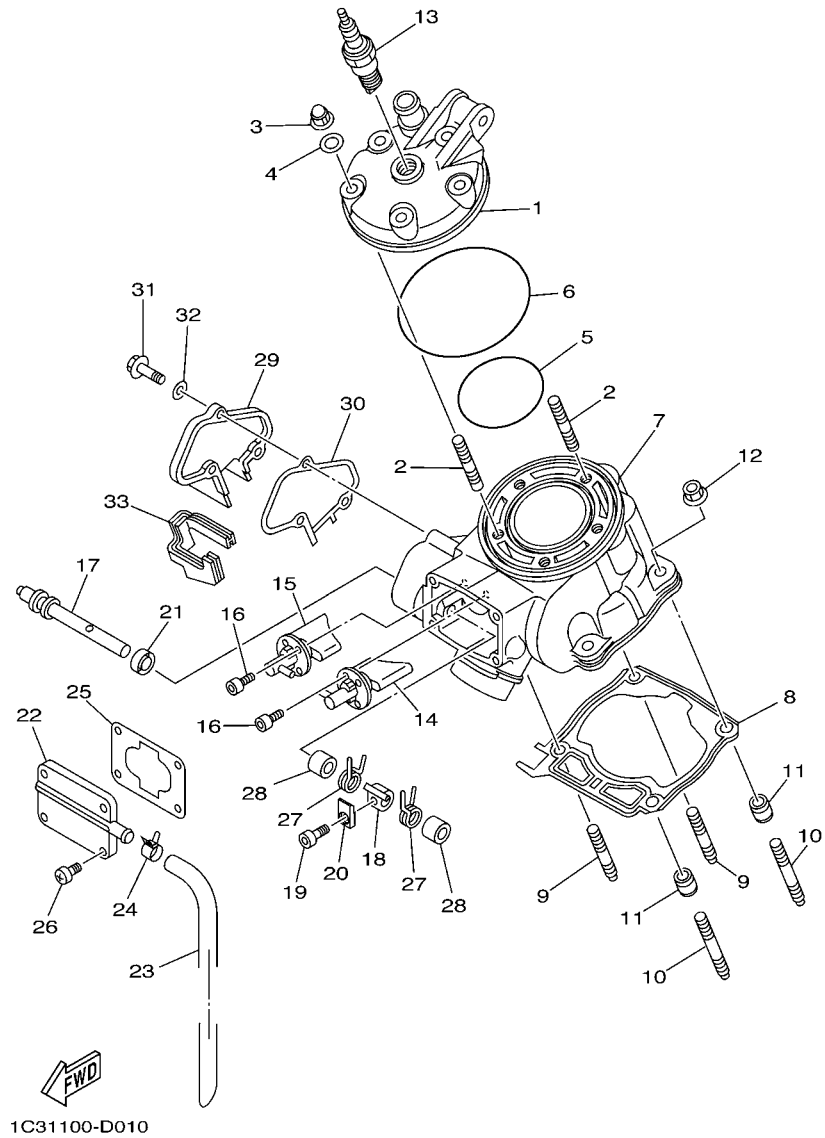
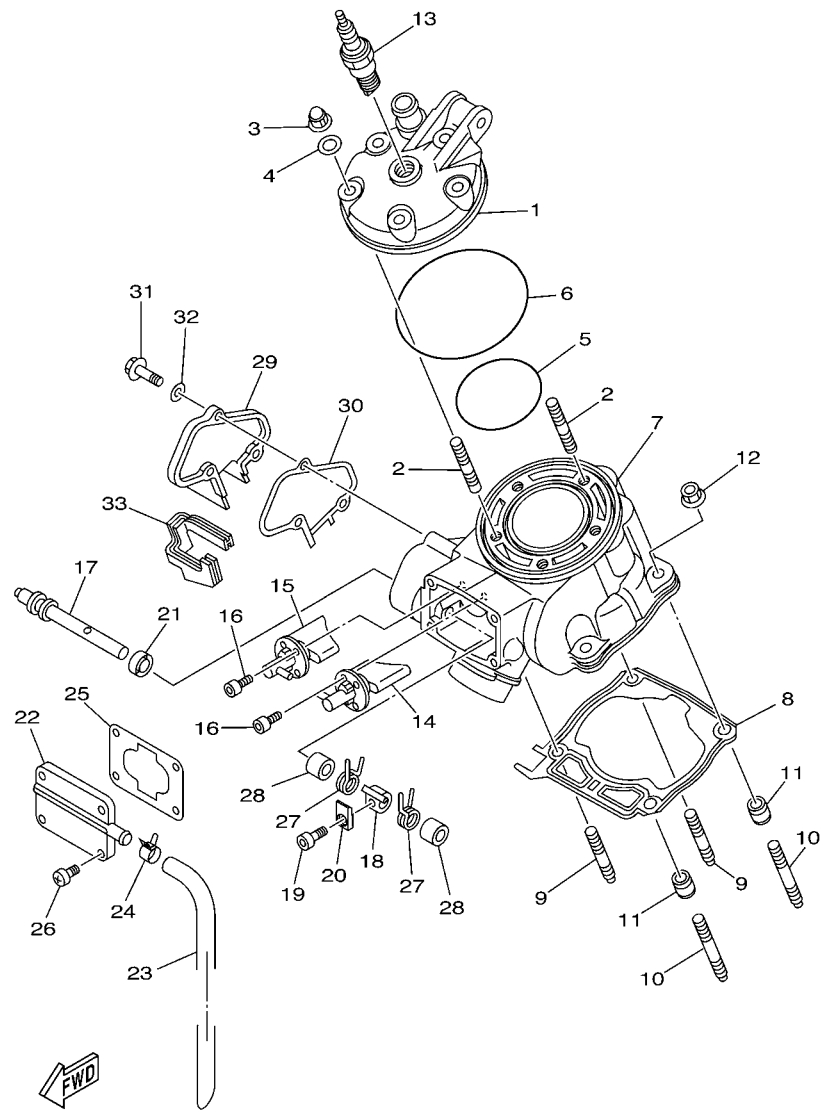

FIG. 1 CYLINDER HEAD

REF. NO.	PART NO.	DESCRIPTION	1SR9	1SFA	1SRB	1SRC	REMARKS
1	1C3-11111-10	HEAD, CYLINDER 1	1	1	1	1	
2	90116-08027	BOLT, STUD	5	5	5	5	
3	90176-08005	NUT, CROWN	5	5	5	5	
4	90201-080L8	WASHER, PLATE	5	5	5	5	
5	93210-63442	O-RING	1	1	1	1	
6	93210-90785	O-RING	1	1	1	1	
7	1C3-11311-20	CYLINDER 1	1	1	1	1	
8	1C3-11351-00	GASKET, CYLINDER	1	1	1	1	
9	90116-08031	BOLT, STUD	2	2	2	2	
10	90116-08028	BOLT, STUD	2	2	2	2	
11	99590-10114	PIN, DOWEL	2	2	2	2	
12	90179-08019	NUT	4	4	4	4	
13	94702-00193	PLUG, SPARK (NGK BR9EVX)	1	1		1	
	94709-00193	PLUG, SPARK (NGK BR-9EVX)			1		
14	1C3-1131D-00	VALVE ASSY	1	1	1	1	
15	1C3-1132D-00	VALVE ASSY 2	1	1	1	1	
16	91312-05012	BOLT	4	4	4	4	
17	5HD-1131V-00	SHAFT 1	1	1	1	1	
18	4SS-11832-00	LEVER, LINK	1	1	1	1	
19	91312-04010	BOLT	1	1	1	1	
20	5UN-11395-00	HOLDER	1	1	1	1	
21	93104-08040	OIL SEAL	1	1	1	1	
22	4SS-1131M-01	COVER	1	1	1	1	
23	4JY-11166-00	PIPE, BREATHER 1	1	1	1	1	
24	90467-13062	CLIP	1	1	1	1	
25	1C3-11354-00	GASKET	1	1	1	1	
26	98902-05016	SCREW, BIND	4	4	4	4	



1C31100-D010

FIG. 1 CYLINDER HEAD

REF. NO.	PART NO.	DESCRIPTION	1SR9	1SFA	1SRB	1SRC	REMARKS
27	90508-16134	SPRING, TORSION	2	2	2	2	
28	90387-08785	COLLAR	2	2	2	2	
29	1C3-11992-00	HOUSING 2	1	1	1	1	
30	1C3-11993-00	GASKET	1	1	1	1	
31	97002-05016	BOLT	3	3	3	3	
32	92902-05600	WASHER, PLATE	3	3	3	3	
33	1C3-11995-00	SEAL, HOUSING	1	1	1	1	

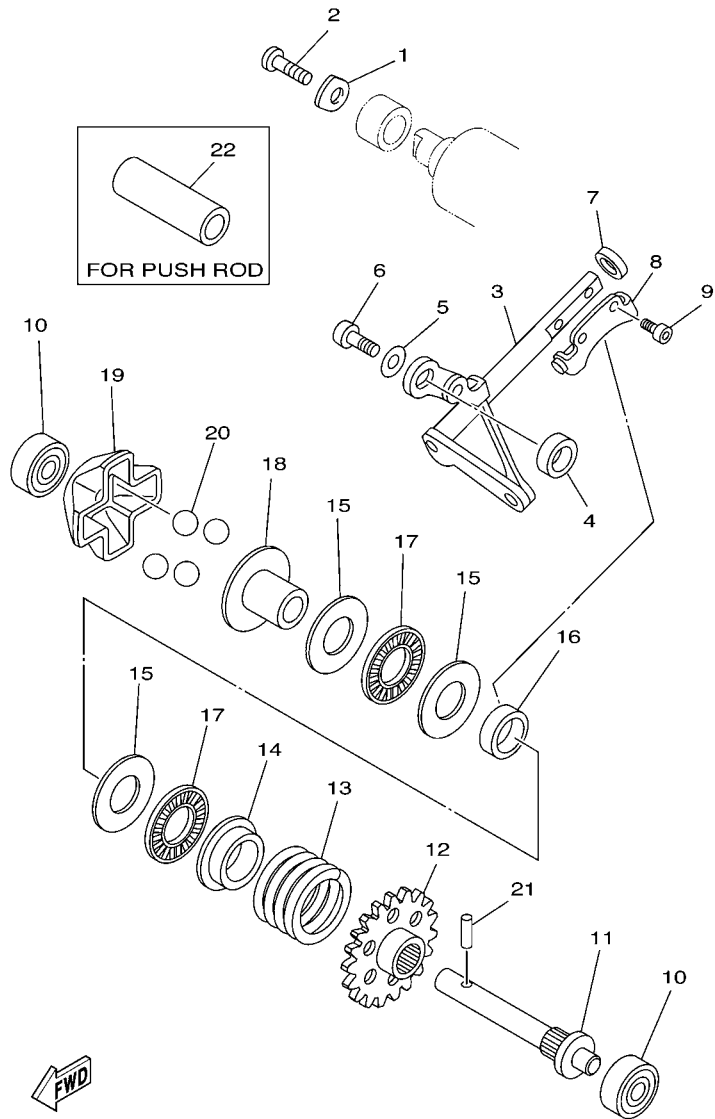

5NY1100-A020

FIG. 2 GOVERNOR

REF. NO.	PART NO.	DESCRIPTION	1SR9	1SFA	1SRB	1SRC	REMARKS
1	4JY-11915-10	PLATE, THRUST 1	1	1	1	1	
2	98502-05012	SCREW, PAN HEAD	1	1	1	1	
3	1C3-11990-10	PUSH ROD ASSY	1	1	1	1	
4	90387-085E1	COLLAR	1	1	1	1	
5	90201-05021	WASHER, PLATE	1	1	1	1	
6	97002-05012	BOLT	1	1	1	1	
7	93104-08040	OIL SEAL	1	1	1	1	
8	3JE-11922-01	FORK, GOVERNOR	1	1	1	1	
9	91312-04006	BOLT	2	2	2	2	
10	93300-60801	BEARING	2	2	2	2	KOYO
11	5X4-11921-02	SHAFT, GOVERNOR	1	1	1	1	
12	5NY-11953-00	GEAR, GOVERNOR	1	1	1	1	
13	90501-300A0	SPRING, COMPRESSION	1	1	1	1	
14	5CU-11952-00	PLATE	1	1	1	1	
15	90201-150U6	WASHER, PLATE	3	3	3	3	
16	90387-152F2	COLLAR	1	1	1	1	
17	93340-21505	BEARING	2	2	2	2	
18	5CU-11912-00	RETAINER, WEIGHT	1	1	1	1	
19	5CU-11911-00	RETAINER	1	1	1	1	
20	93507-16020	BALL	4	4	4	4	
21	93603-14240	PIN, DOWEL	1	1	1	1	
22	90387-107T9	COLLAR	1	1	1	1	AP

FIG. 3 CRANKSHAFT & PISTON

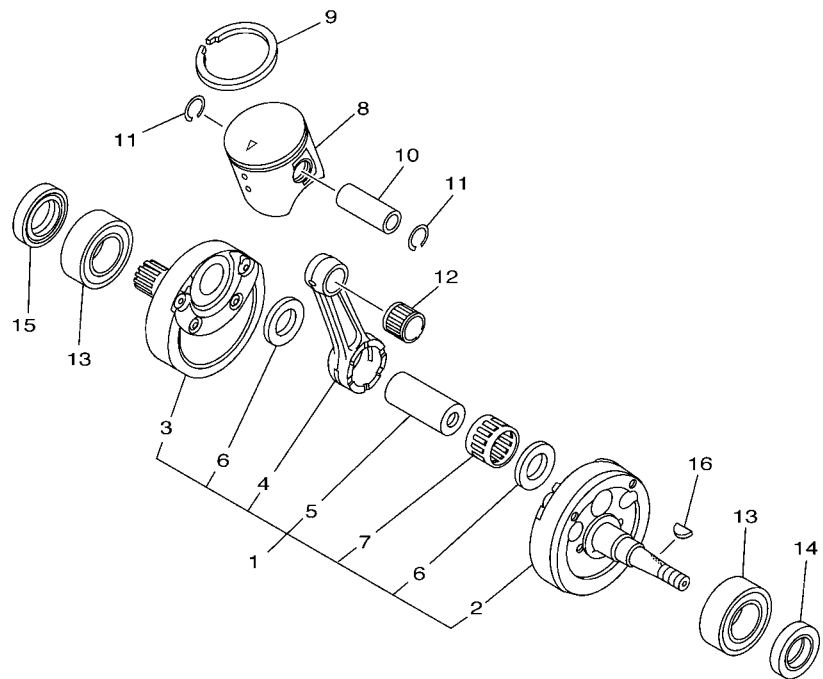

5NY1100-A030

REF. NO.	PART NO.	DESCRIPTION	1SR9	1SFA	1SRB	1SRC	REMARKS
1	1C3-11400-20	CRANKSHAFT ASSY	1	1	1	1	
2	1C3-11410-10	.CRANKSHAFT	1	1	1	1	
3	1C3-11420-20	.CRANKSHAFT	1	1	1	1	
4	1C3-11651-00	.ROD, CONNECTING	1	1	1	1	
5	3JD-11681-10	.PIN, CRANK 1	1	1	1	1	
6	90209-22326	.WASHER	2	2	2	2	
7	93310-52238	.BEARING	1	1	1	1	
8	1C3-11631-02-A0	PISTON (STD)	1	1	1	1	UR RED
	1C3-11631-02-B0	PISTON (STD)	1	1	1	1	UR ORANGE
	1C3-11631-02-C0	PISTON (STD)	1	1	1	1	UR GREEN
	1C3-11631-02-D0	PISTON (STD)	1	1	1	1	UR PURPLE
9	5NY-11611-00	RING, PISTON	1	1	1	1	
10	1C3-11633-00	PIN, PISTON	1	1	1	1	
11	93450-16068	CIRCLIP	2	2	2	2	
12	93310-21510	BEARING	1	1	1	1	
13	93306-37204	BEARING	2	2	2	2	KOYO
14	93102-20485	OIL SEAL	1	1	1	1	
15	93102-22419	OIL SEAL	1	1	1	1	
16	90280-03045	KEY, WOODRUFF	1	1	1	1	

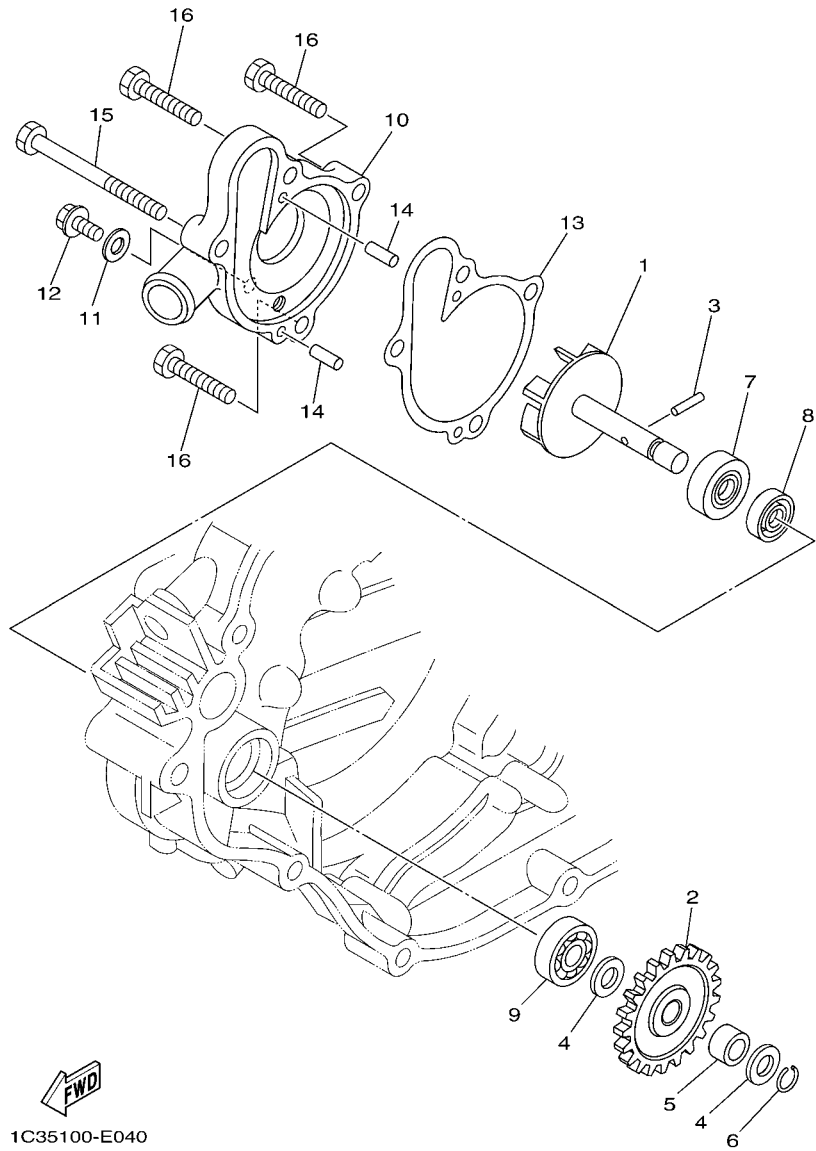

1C35100-E040

FIG. 4 WATER PUMP

REF. NO.	PART NO.	DESCRIPTION	1SR9	1SFA	1SRB	1SRC	REMARKS
1	1C3-12450-00	IMPELLER SHAFT ASSY	1	1	1	1	
2	1C3-12453-10	GEAR	1	1	1	1	
3	93603-12007	PIN, DOWEL	1	1	1	1	
4	90201-08512	WASHER, PLATE	2	2	2	2	
5	90387-08032	COLLAR	1	1	1	1	
6	93440-07182	CIRCLIP	1	1	1	1	
7	93102-08004	OIL SEAL	1	1	1	1	
8	93102-08307	OIL SEAL	1	1	1	1	
9	93300-60801	BEARING	1	1	1	1	UR KOYO
	93300-60814	BEARING	1	1	1	1	UR NMB
10	1C3-12422-00	COVER, HOUSING	1	1	1	1	
11	90430-06014	GASKET	1	1	1	1	
12	95022-06010	BOLT, FLANGE	1	1	1	1	
13	1C3-12428-00	GASKET, HOUSING COVER 2	1	1	1	1	
14	93604-10011	PIN, DOWEL	2	2	2	2	
15	95022-06065	BOLT, FLANGE	1	1	1	1	
16	95022-06025	BOLT, FLANGE	3	3	3	3	

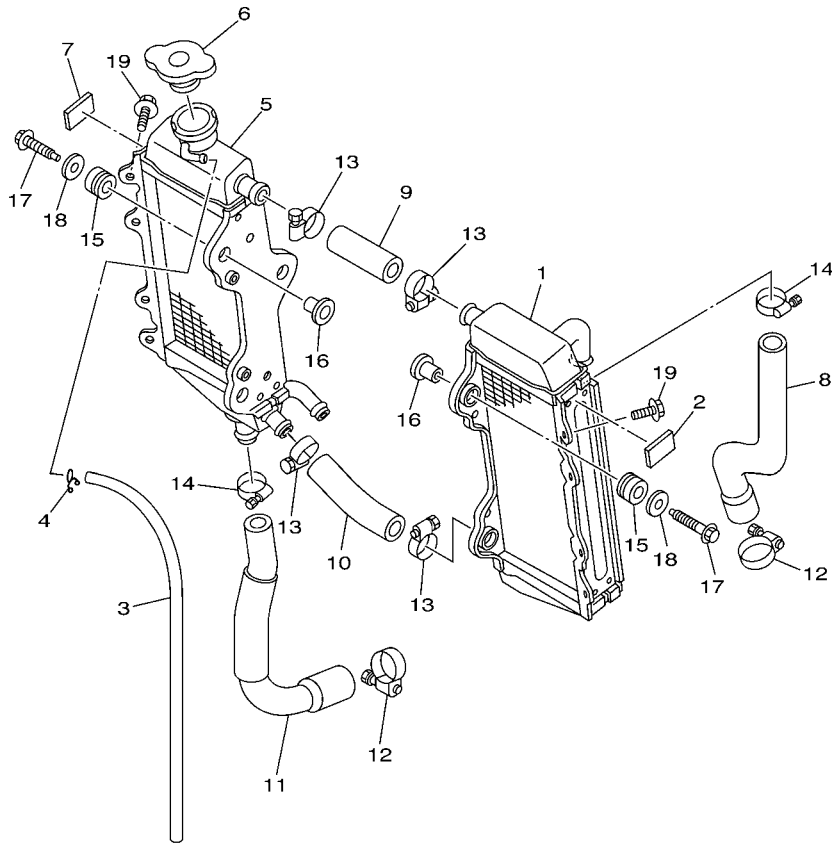

1C31100-D050

FIG. 5 RADIATOR & HOSE

REF. NO.	PART NO.	DESCRIPTION	1SR9	1SFA	1SRB	1SRC	REMARKS
1	1C3-1240A-00	RADIATOR ASSY	1	1	1	1	
2	1C3-12465-00	DAMPER, RADIATOR	1	1	1	1	
3	91A20-05065	TUBE, FLEXIBLE VINYL	1	1	1	1	
4	90467-090A2	CLIP	1	1	1	1	
5	1C3-12461-00	RADIATOR COMP	1	1	1	1	
6	22W-12462-00	CAP, RADIATOR	1	1	1	1	
7	1C3-12465-00	DAMPER, RADIATOR	1	1	1	1	
8	1C3-12481-00	PIPE 1	1	1	1	1	
9	1C3-12482-00	PIPE 2	1	1	1	1	
10	1C3-12483-00	PIPE 3	1	1	1	1	
11	1C3-12484-00	PIPE 4	1	1	1	1	
12	90450-28001	HOSE CLAMP ASSY	2	2	2	2	
13	90450-22001	HOSE CLAMP ASSY	4	4	4	4	
14	90450-25001	HOSE CLAMP ASSY	2	2	2	2	
15	90480-15528	GROMMET	6	6	6	6	
16	90387-06065	COLLAR	6	6	6	6	
17	90105-06111	BOLT, FLANGE	6	6	6	6	
18	90201-06571	WASHER, PLATE	6	6	6	6	
19	90105-06118	BOLT, FLANGE	2	2	2	2	

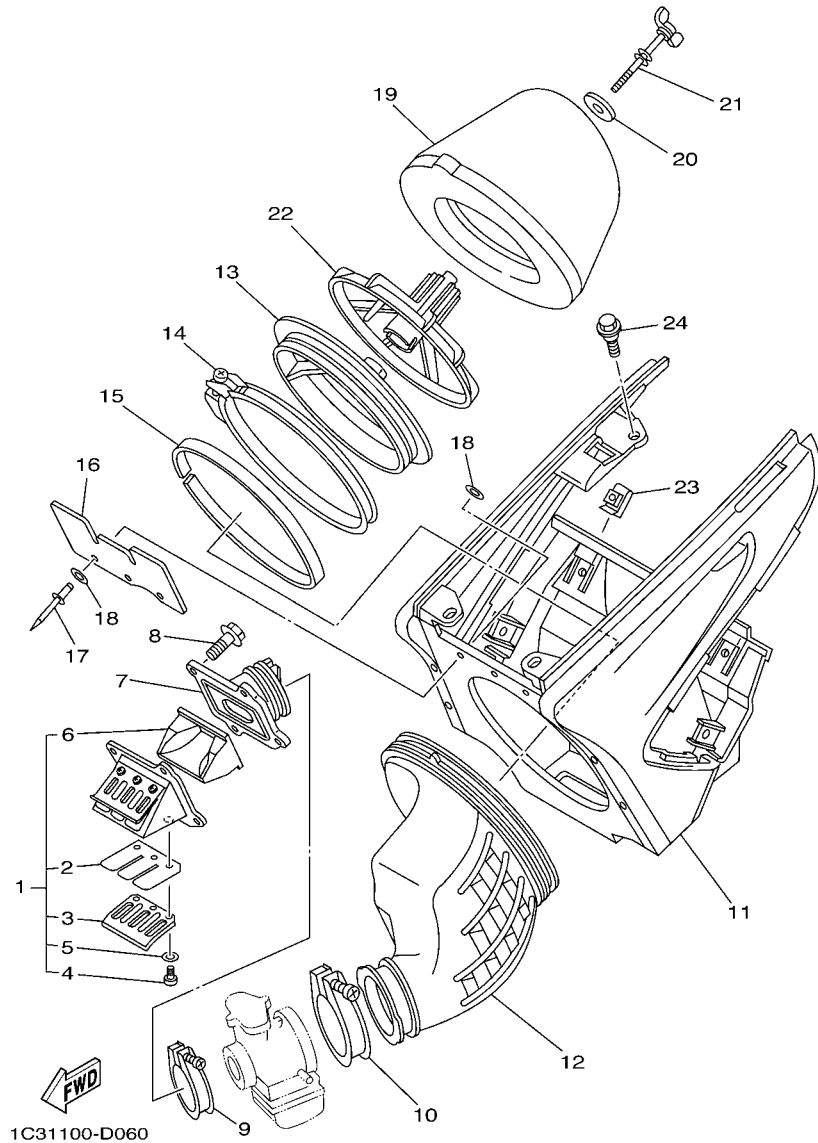
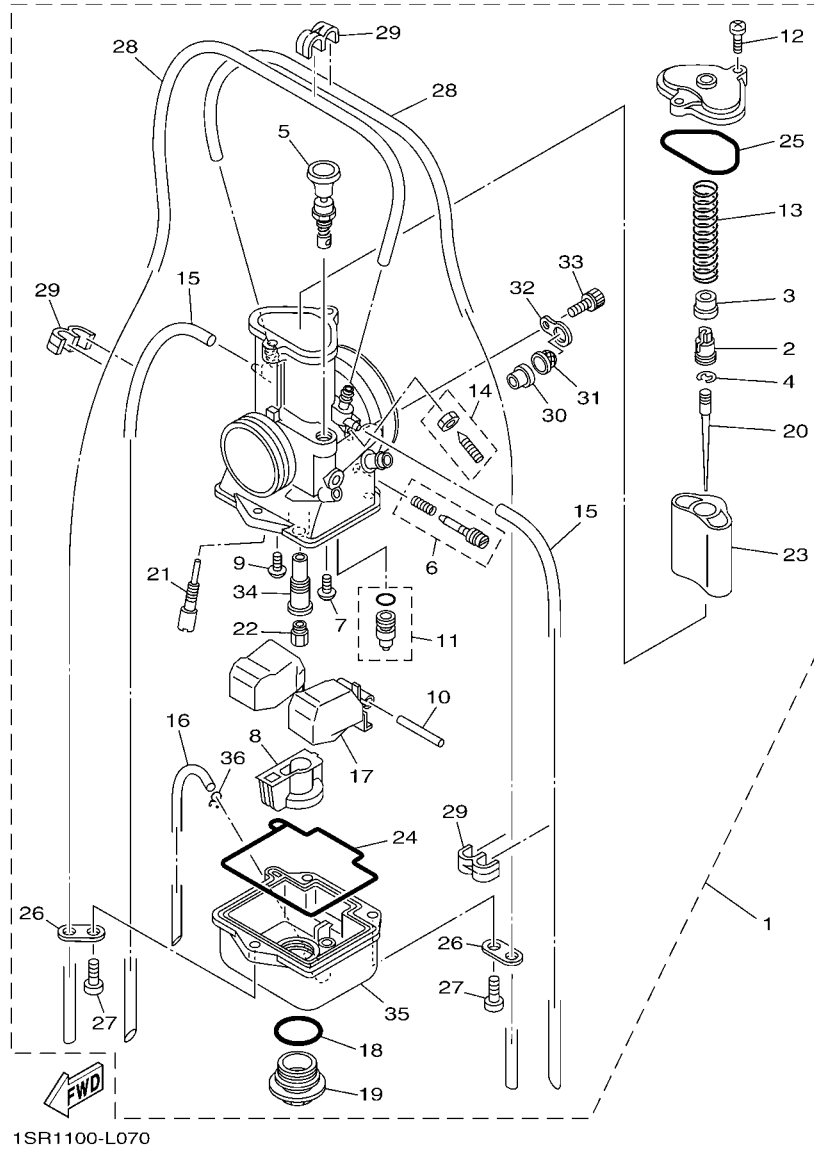

FIG. 6 INTAKE

REF. NO.	PART NO.	DESCRIPTION	1SR9	1SFA	1SRB	1SRC	REMARKS
1	1C3-13610-20	REED VALVE ASSY	1	1	1	1	
2	5UN-13613-00	.REED, VALVE	2	2	2	2	
3	5MV-13616-10	.STOPPER, REED VALVE	2	2	2	2	
4	98502-03006	.SCREW, PAN HEAD	6	6	6	6	
5	92902-03100	.WASHER	6	6	6	6	
6	1C3-13625-10	.SPACER, REED VALVE	1	1	1	1	
7	1C3-13565-00	JOINT, CARBURETOR	1	1	1	1	
8	95022-06020	BOLT, FLANGE	4	4	4	4	
9	90450-54007	HOSE CLAMP ASSY	1	1	1	1	
10	90450-70002	HOSE CLAMP ASSY	1	1	1	1	
11	5NY-14401-01	AIR CLEANER CASE ASSY	1	1	1	1	
12	1C3-14453-10	JOINT, AIR CLEANER 1	1	1	1	1	
13	5NY-14459-00	HOLDER, GUIDE	1	1	1	1	
14	5NY-14455-20	BAND	1	1	1	1	
15	5NY-14442-00	SPACER	1	1	1	1	
16	5NY-14417-00	COVER 1	1	1	1	1	
17	90267-32070	RIVET, BLIND	3	3	3	3	
18	90201-03313	WASHER, PLATE	6	6	6	6	
19	4XM-14451-00	ELEMENT, AIR CLEANER	1	1	1	1	
20	90209-06096	WASHER	1	1	1	1	
21	90122-06005	BOLT, WING	1	1	1	1	
22	3JD-14458-01	GUIDE	1	1	1	1	
23	90183-06023	NUT, SPRING	4	4	4	4	
24	90109-06245	BOLT	4	4	4	4	



1SR1100-L070

FIG. 7 CARBURETOR

REF. NO.	PART NO.	DESCRIPTION	1SR9	1SFA	1SRB	1SRC	REMARKS
1	1C3-14101-51	CARBURETOR ASSY 1	1		1		
	1C3-14101-41	CARBURETOR ASSY 1		1		1	
2	5HD-14261-00	.HOLDER	1	1	1	1	
3	4PE-14194-00	.RING	1	1	1	1	
4	3MA-14159-00	.CLIP	1	1	1	1	
5	3JE-14171-00	.PLUNGER, STARTER	1	1	1	1	
6	5UN-14104-00	.AIR SCREW SET	1	1	1	1	
7	1FN-14565-00	.SCREW	1	1	1	1	
8	5ET-14261-01	.HOLDER	1	1	1	1	
9	98507-04008	.SCREW, PAN HEAD	1	1	1	1	
10	353-14186-00	.PIN, FLOAT	1	1	1	1	
11	4PE-14107-38	.NEEDLE VALVE SET	1	1	1	1	
12	98507-04014	.SCREW, PAN HEAD	2	2	2	2	
13	4PE-14131-00	.SPRING, THROTTLE VALVE	1	1	1	1	
14	4PE-14103-00	.THROTTLE SCREW SET	1	1	1	1	
15	5ET-14197-00	.PIPE	2	2	2	2	
16	10V-14196-00	.PIPE, OVER FLOW 1	1	1	1	1	
17	5ET-14185-00	.FLOAT	1	1	1	1	
18	2K6-14147-00	.O-RING	1	1	1	1	
19	5ET-14115-00	.PLUG, SCREW	1	1	1	1	
20	284-14116-J4	.NEEDLE (6BFY43-74)	1	1	1	1	STD
	284-14116-H2	.NEEDLE (6BFY42-72)	1	1	1	1	AP
	284-14116-H3	.NEEDLE (6BFY42-73)	1	1	1	1	AP
	284-14116-H4	.NEEDLE (6BFY42-74)	1	1	1	1	AP
	284-14116-H5	.NEEDLE (6BFY42-75)	1	1	1	1	AP
	284-14116-H6	.NEEDLE (6BFY42-76)	1	1	1	1	AP
	284-14116-J2	.NEEDLE (6BFY43-72)	1	1	1	1	AP

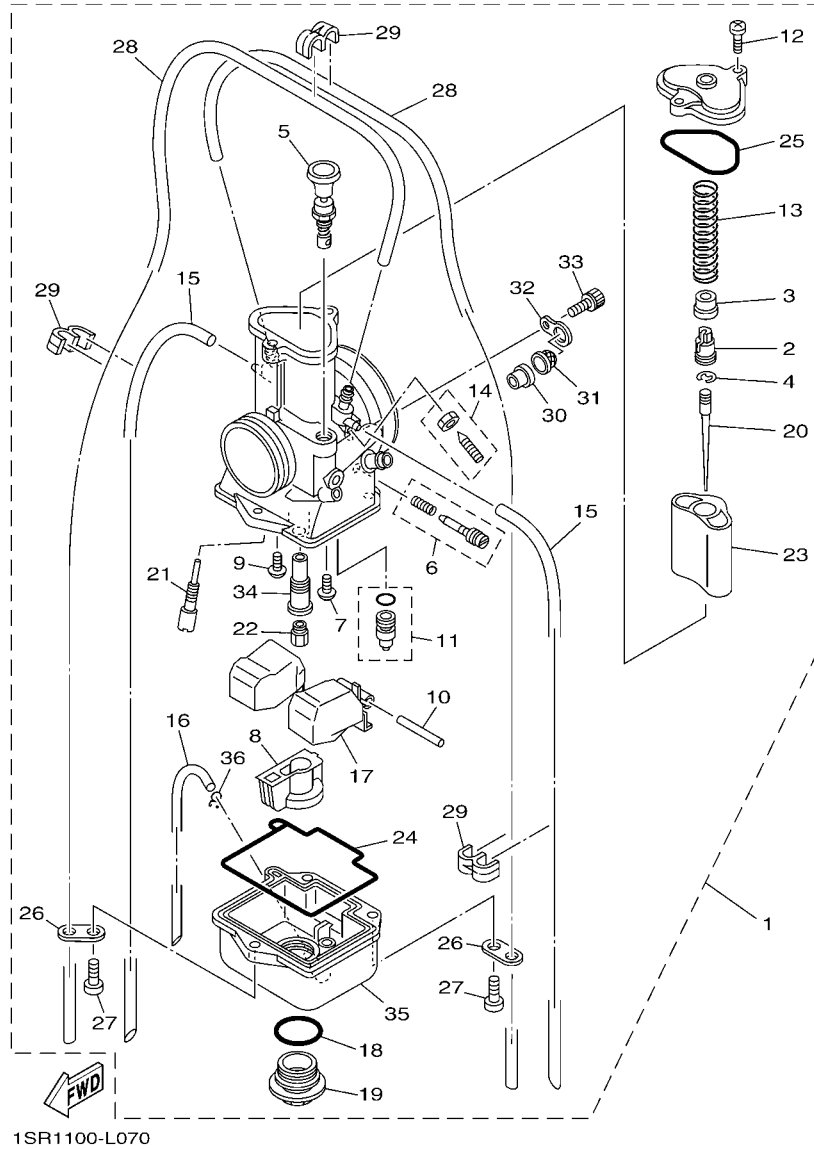

FIG. 7 CARBURETOR

REF. NO.	PART NO.	DESCRIPTION	1SR9	1SFA	1SRB	1SRC	REMARKS
20	284-14116-J3	.NEEDLE (6BFY43-73)	1	1	1	1	AP
	284-14116-J5	.NEEDLE (6BFY43-75)	1	1	1	1	AP
	284-14116-J6	.NEEDLE (6BFY43-76)	1	1	1	1	AP
	284-14116-K2	.NEEDLE (6BFY44-72)	1	1	1	1	AP
	284-14116-K3	.NEEDLE (6BFY44-73)	1	1	1	1	AP
	284-14116-K4	.NEEDLE (6BFY44-74)	1	1	1	1	AP
	284-14116-K5	.NEEDLE (6BFY44-75)	1	1	1	1	AP
	284-14116-K6	.NEEDLE (6BFY44-76)	1	1	1	1	AP
21	4KM-14142-40	.JET, PILOT (# 40)	1		1		STD
	4KM-14142-45	.JET, PILOT (# 45)		1		1	STD
	4KM-14142-30	.JET, PILOT (# 30)	1	1	1	1	AP
	4KM-14142-32	.JET, PILOT (# 32.5)	1	1	1	1	AP
	4KM-14142-35	.JET, PILOT (# 35)	1	1	1	1	AP
	4KM-14142-37	.JET, PILOT (# 37.5)	1	1	1	1	AP
	4KM-14142-40	.JET, PILOT (# 40)		1		1	AP
	4KM-14142-42	.JET, PILOT (# 42.5)	1	1	1	1	AP
	4KM-14142-45	.JET, PILOT (# 45)	1		1		AP
	4KM-14142-47	.JET, PILOT (# 47.5)	1	1	1	1	AP
	4KM-14142-50	.JET, PILOT (# 50)	1	1	1	1	AP
22	137-14143-86	.JET, MAIN (#430)	1	1	1	1	STD
	137-14143-80	.JET, MAIN (#400)	1	1	1	1	AP
	137-14143-82	.JET, MAIN (#410)	1	1	1	1	AP
	137-14143-84	.JET, MAIN (#420)	1	1	1	1	AP
	137-14143-88	.JET, MAIN (#440)	1	1	1	1	AP
	137-14143-90	.JET, MAIN (#450)	1	1	1	1	AP
	137-14143-92	.JET, MAIN (#460)	1	1	1	1	AP
	137-14143-94	.JET, MAIN (#470)	1	1	1	1	AP

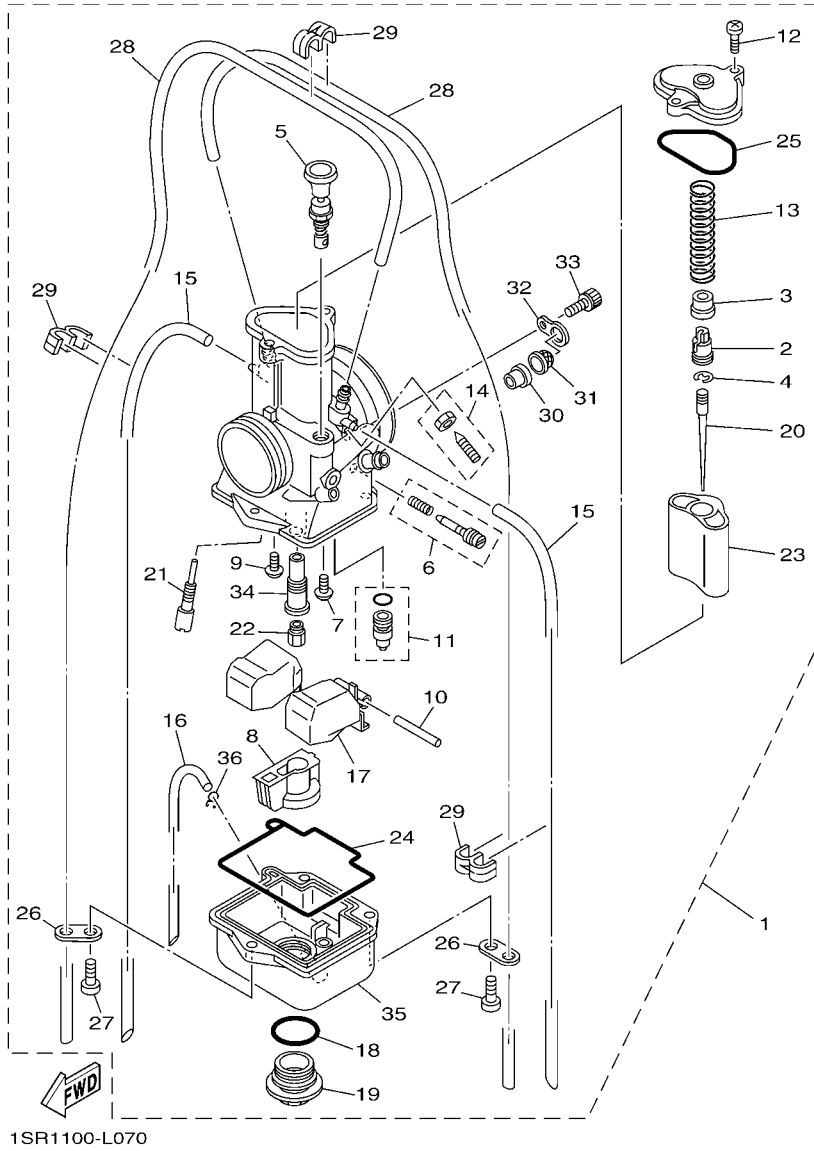
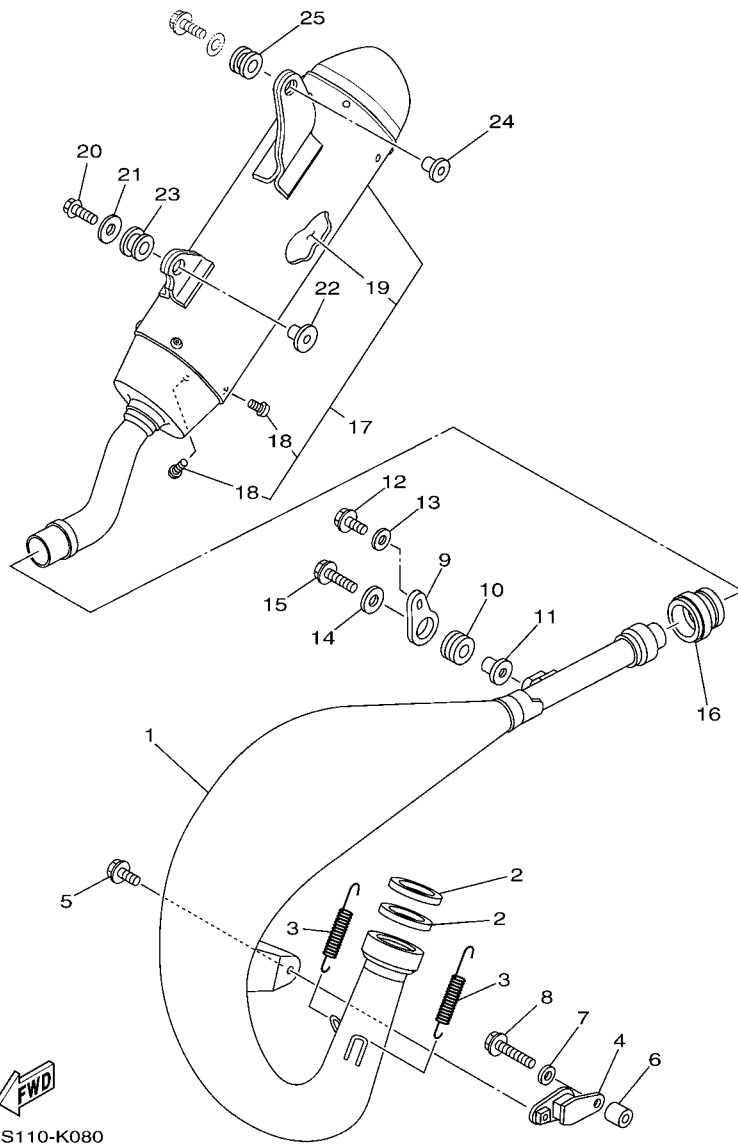

FIG. 7 CARBURETOR

REF. NO.	PART NO.	DESCRIPTION	1SR9	1SFA	1SRB	1SRC	REMARKS
23	1C3-14112-40	.VALVE, THROTTLE 1 (4.0)	1	1	1	1	STD
	1C3-14112-42	.VALVE, THROTTLE 1 (4.25)	1	1	1	1	AP
24	5ET-1416A-00	.O-RING	1	1	1	1	
25	5ET-14147-00	.O-RING	1	1	1	1	
26	51R-14146-00	.PLATE	2	2	2	2	
27	98502-05014	.SCREW, PAN HEAD	3	3	3	3	
28	2HH-14197-00	.PIPE	2	2	2	2	
29	87M-14137-00	.CLIP	3	3	3	3	
30	5MV-14194-00	.RING	1	1	1	1	
31	5MV-24514-00	.NET, FILTER 1	1	1	1	1	
32	5MV-14146-00	.PLATE	1	1	1	1	
33	5MV-14216-00	.SCREW	1	1	1	1	
34	5MV-14261-00	.HOLDER	1	1	1	1	
35	5NY-14181-00	.BODY, FLOAT CHAMBER 1	1	1	1	1	
36	22F-14139-00	.CLIP, PIPE	1	1	1	1	



1C3S110-K080

FIG. 8 EXHAUST

REF. NO.	PART NO.	DESCRIPTION	1SR9	1SFA	1SRB	1SRC	REMARKS
1	1C3-14610-00	EXHAUST PIPE ASSY 1	1	1	1	1	
2	5MV-14642-00	SEAL, EXHAUST	2	2	2	2	
3	90506-20018	SPRING, TENSION	2	2	2	2	
4	565-14771-00	STAY, MUFFLER 1	1	1	1	1	
5	95022-06012	BOLT, FLANGE	1	1	1	1	
6	1C3-14763-00	SPACER	1	1	1	1	
7	90201-06077	WASHER, PLATE	1	1	1	1	
8	95022-06025	BOLT, FLANGE	1	1	1	1	
9	5CU-14771-01	STAY, MUFFLER 1	1	1	1	1	
10	90480-16561	GROMMET	1	1	1	1	
11	90387-063G3	COLLAR	1	1	1	1	
12	95022-06014	BOLT, FLANGE	1	1	1	1	
13	90201-06078	WASHER, PLATE	1	1	1	1	
14	90201-06033	WASHER, PLATE	1	1	1	1	
15	95022-06025	BOLT, FLANGE	1	1	1	1	
16	4JY-14615-00	JOINT, EXHAUST 1	1	1	1	1	
17	1C3-14753-00	SILENCER, EXHAUST	1	1	1	1	
18	92012-06010	.BOLT, BUTTON HEAD	4	4	4	4	
19	1C3-1469A-00	.FIBER	1	1	1	1	
20	95022-06030	BOLT, FLANGE	1	1	1	1	
21	90201-06086	WASHER, PLATE	1	1	1	1	
22	90387-06121	COLLAR	1	1	1	1	
23	90480-17004	GROMMET	1	1	1	1	
24	90387-06039	COLLAR	1	1	1	1	
25	90480-16404	GROMMET	1	1	1	1	

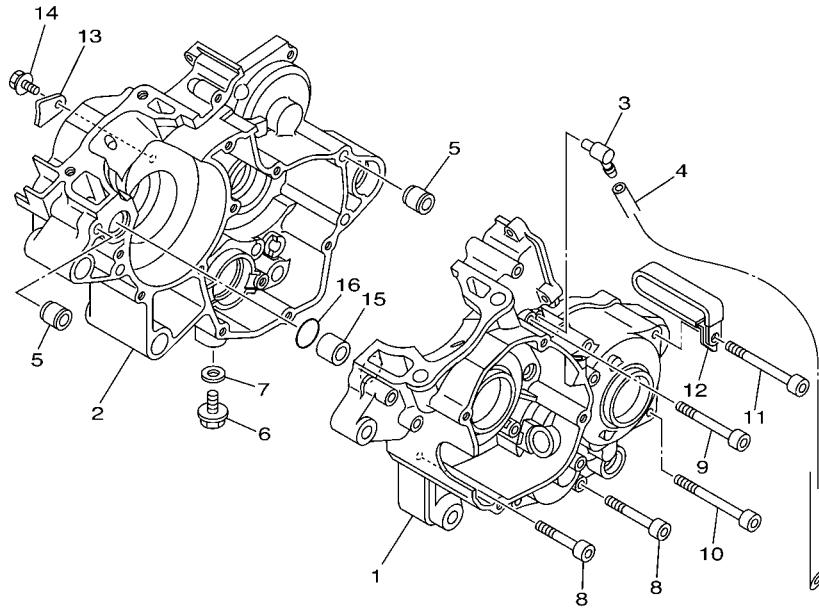
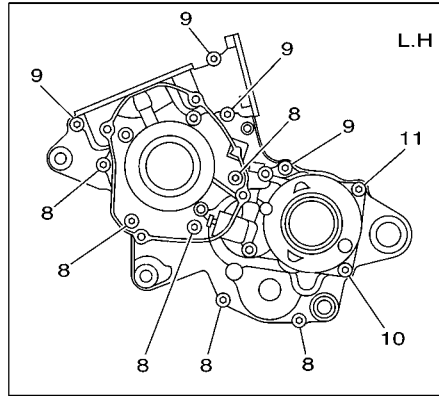

1C31100-D090

FIG. 9 CRANKCASE

REF. NO.	PART NO.	DESCRIPTION	1SR9	1SFA	1SRB	1SRC	REMARKS
1	1C3-15111-01	CRANKCASE 1	1	1	1	1	
2	1C3-15121-00	CRANKCASE 2	1	1	1	1	
3	353-13115-01	CONNECTOR, SUCTION PIPE	1	1	1	1	
4	90445-08605	HOSE	1	1	1	1	
5	99530-10116	PIN, DOWEL	2	2	2	2	
6	95022-10016	BOLT, FLANGE	1	1	1	1	
7	90430-10188	GASKET	1	1	1	1	
8	91312-06045	BOLT	6	6	6	6	
9	91312-06055	BOLT	4	4	4	4	
10	91312-06065	BOLT	1	1	1	1	
11	91312-06075	BOLT	1	1	1	1	
12	90461-10136	CLAMP	1	1	1	1	
13	4V4-15118-00	HOLDER	1	1	1	1	
14	90105-06085	BOLT, FLANGE	1	1	1	1	
15	99590-17016	PIN, DOWEL	1	1	1	1	
16	93210-16314	O-RING	1	1	1	1	

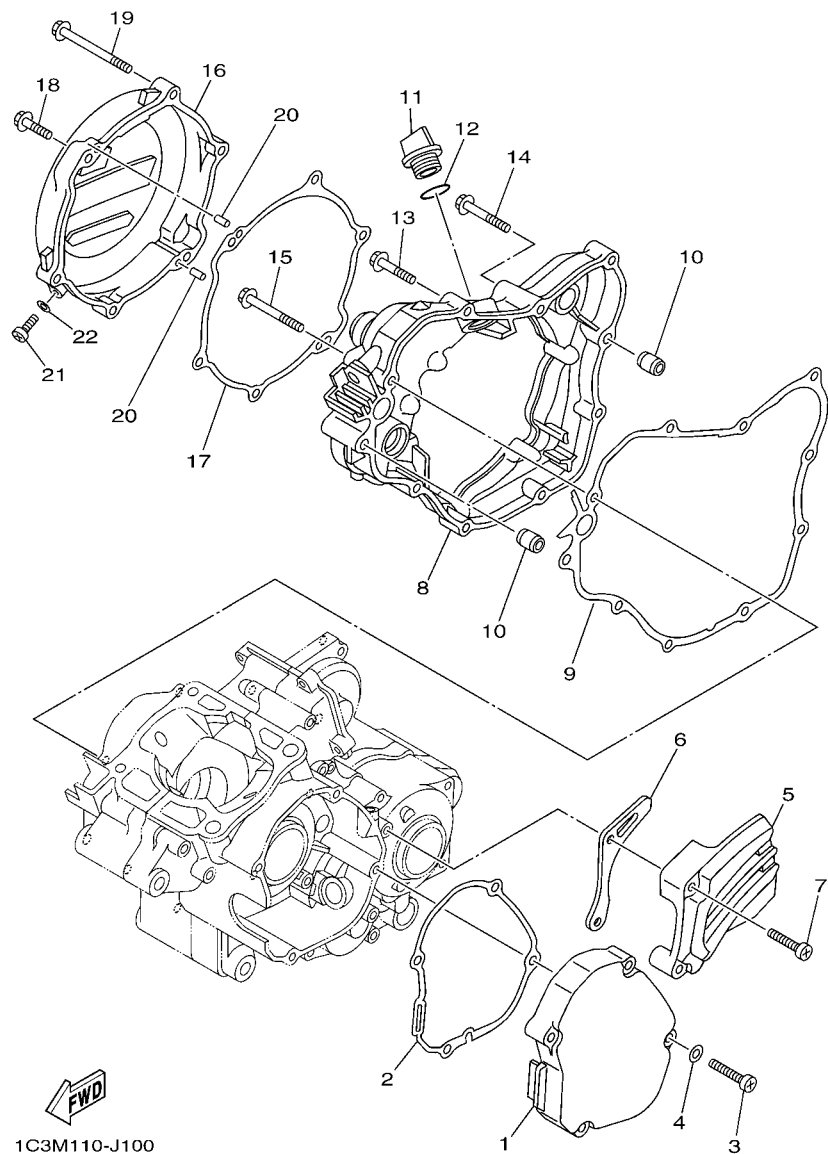
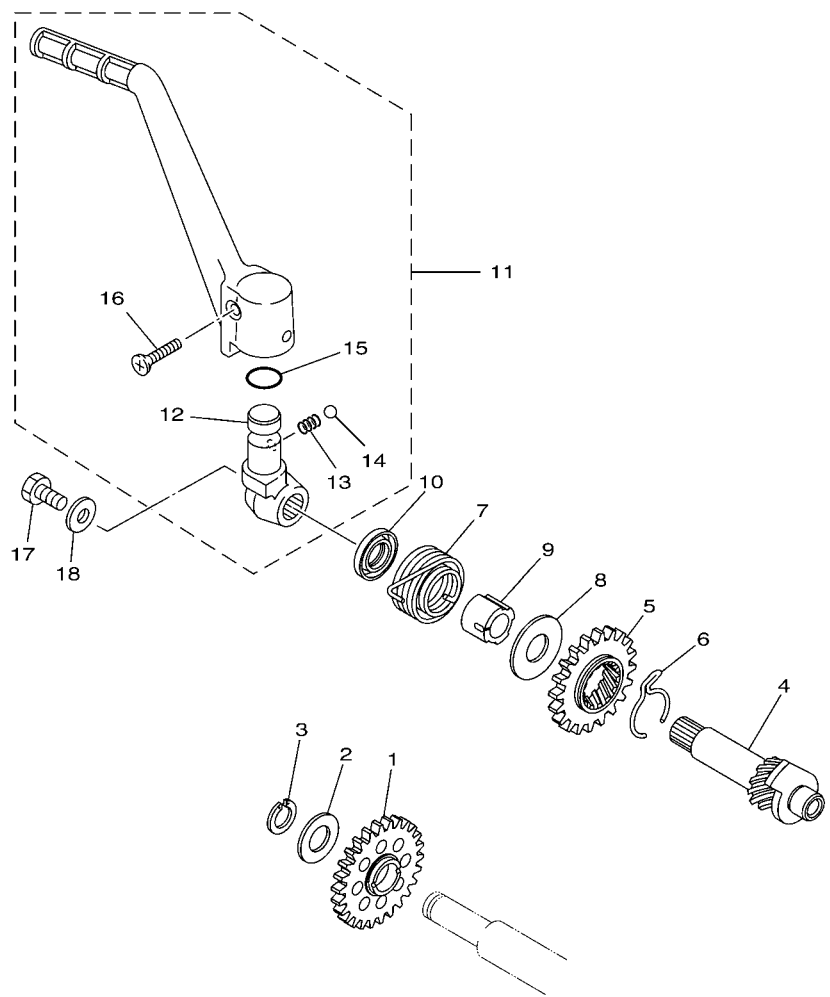

FIG. 10 CRANKCASE COVER 1

REF. NO.	PART NO.	DESCRIPTION	1SR9	1SFA	1SRB	1SRC	REMARKS
1	1C3-15411-10	COVER, CRANKCASE 1	1	1	1	1	
2	1C3-15451-00	GASKET, CRANKCASE COVER 1	1	1	1	1	
3	92502-06030	SCREW, PAN HEAD	4	4	4	4	
4	92902-06600	WASHER, PLATE	4	4	4	4	
5	1C3-15421-10	COVER, CRANKCASE 2	1	1	1	1	
6	1C3-17466-00	GUIDE, CHAIN	1	1	1	1	
7	98502-06030	SCREW, PAN HEAD	2	2	2	2	
8	1C3-15431-00	COVER, CRANKCASE 3	1	1	1	1	
9	1C3-15462-00	GASKET, CRANKCASE COVER 3	1	1	1	1	
10	99530-08016	PIN, DOWEL	2	2	2	2	
11	3Y1-15363-10	PLUG, OIL	1	1	1	1	
12	93210-19123	O-RING	1	1	1	1	
13	95022-06030	BOLT, FLANGE	6	6	6	6	
14	95022-06040	BOLT, FLANGE	1	1	1	1	
15	95022-06050	BOLT, FLANGE	1	1	1	1	
16	1C3-15415-10	COVER, GENERATOR	1	1	1	1	
17	1C3-15463-00	GASKET, COVER PINION 2	1	1	1	1	
18	95022-06065	BOLT, FLANGE	1	1	1	1	
19	95022-06025	BOLT, FLANGE	5	5	5	5	
20	93604-10011	PIN, DOWEL	2	2	2	2	
21	92012-06012	BOLT, BUTTON HEAD	1	1	1	1	
22	90430-06014	GASKET	1	1	1	1	

FIG. 11 STARTER



1C31100-D110

REF. NO.	PART NO.	DESCRIPTION	1SR9	1SFA	1SRB	1SRC	REMARKS
1	1C3-15651-00	GEAR, KICK IDLE	1	1	1	1	
2	90201-175F6	WASHER, PLATE	1	1	1	1	
3	99009-17400	CIRCLIP	1	1	1	1	
4	1C3-15660-00	KICK AXLE ASSY	1	1	1	1	
5	1C3-15641-00	GEAR, KICK	1	1	1	1	
6	90468-26048	CLIP	1	1	1	1	
7	90508-26450	SPRING, TORSION	1	1	1	1	
8	90201-171G4	WASHER, PLATE	1	1	1	1	
9	1C3-15666-00	SPACER	1	1	1	1	
10	93102-17263	OIL SEAL	1	1	1	1	
11	4DB-15620-10	KICK CRANK ASSY	1	1	1	1	
12	4DB-15621-03	.BOSS, KICK CRANK	1	1	1	1	
13	90501-12081	.SPRING, COMPRESSION	1	1	1	1	
14	93507-32009	.BALL	1	1	1	1	
15	93210-15171	.O-RING	1	1	1	1	
16	90151-06045	.SCREW, COUNTERSUNK	1	1	1	1	
17	97022-06012	BOLT, HEXAGON	1	1	1	1	
18	90201-06060	WASHER, PLATE	1	1	1	1	

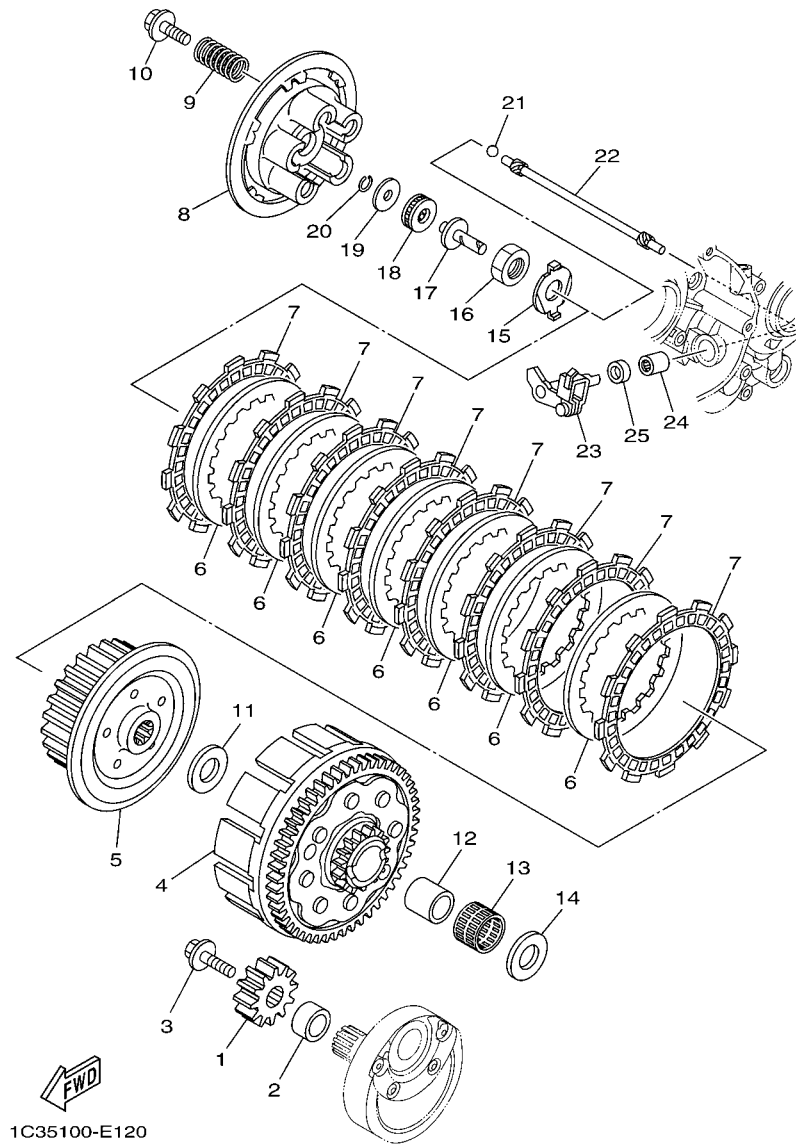

1C35100-E120

FIG. 12 CLUTCH

REF. NO.	PART NO.	DESCRIPTION	1SR9	1SFA	1SRB	1SRC	REMARKS
1	1C3-16111-00	GEAR, PRIMARY DRIVE	1	1	1	1	
2	90387-172K2	COLLAR	1	1	1	1	
3	90105-08071	BOLT, FLANGE	1	1	1	1	
4	1C3-16150-00	PRIMARY DRIVEN GEAR COMP.	1	1	1	1	
5	5NY-16371-00	BOSS, CLUTCH	1	1	1	1	
6	3XJ-16324-01	PLATE, CLUTCH 1	7	7	7	7	
7	3XJ-16321-00	PLATE, FRICTION	8	8	8	8	
8	5HD-16351-00	PLATE, PRESSURE 1	1	1	1	1	
9	90501-23598	SPRING, COMPRESSION	5	5	5	5	
10	90159-06016	SCREW, WITH WASHER	5	5	5	5	
11	90201-20611	WASHER, PLATE	1	1	1	1	
12	1C3-16181-00	SPACER 1	1	1	1	1	
13	93310-22539	BEARING	1	1	1	1	
14	90201-20611	WASHER, PLATE	1	1	1	1	
15	90215-16289	WASHER, LOCK	1	1	1	1	
16	90170-16326	NUT	1	1	1	1	
17	5NL-16356-00	ROD, PUSH 1	1	1	1	1	
18	93340-21008	BEARING	1	1	1	1	
19	90201-080H1	WASHER, PLATE	1	1	1	1	
20	93440-07182	CIRCLIP	1	1	1	1	
21	93511-32027	BALL	1	1	1	1	
22	1C3-16357-10	ROD, PUSH 2	1	1	1	1	
23	1C3-16380-00	PUSH LEVER ASSY	1	1	1	1	
24	93315-11040	BEARING	1	1	1	1	
25	93102-10008	OIL SEAL	1	1	1	1	

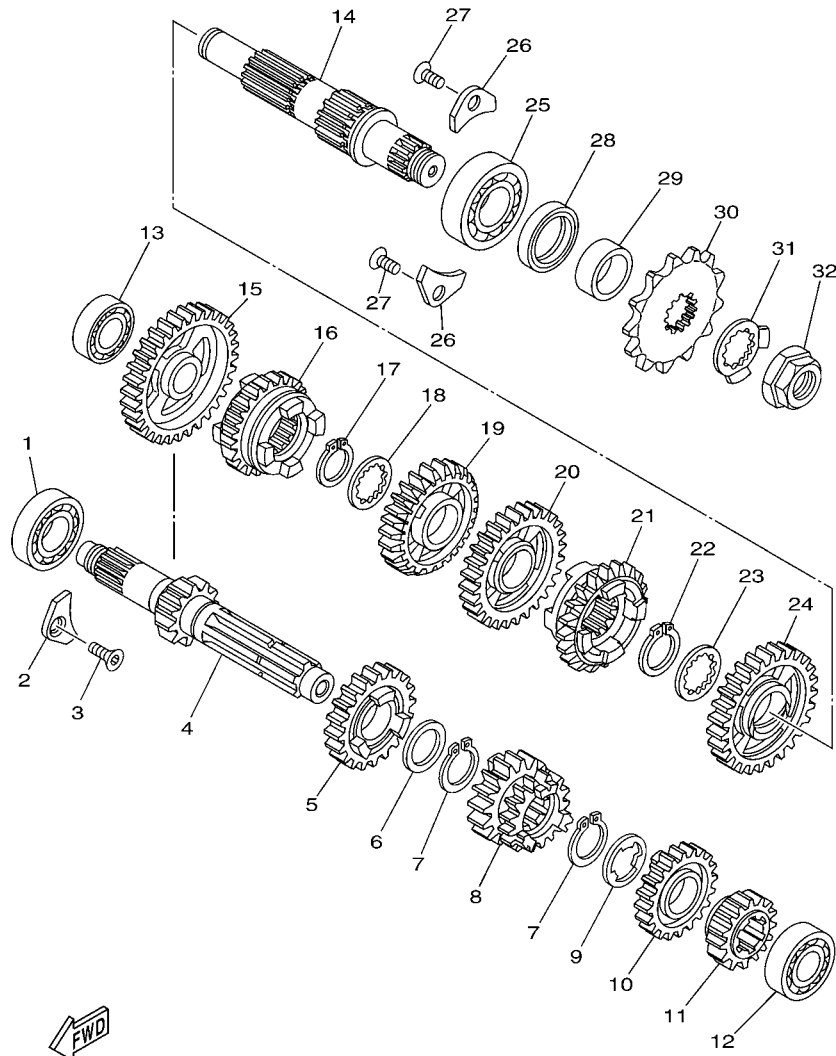

1C31100-D131

FIG. 13 TRANSMISSION

REF. NO.	PART NO.	DESCRIPTION	1SR9	1SRA	1SRB	1SRC	REMARKS
1	93306-00442	BEARING	1	1	1	1	
2	4JT-15381-01	PLATE, BEARING COVER	1	1	1	1	
3	90149-06074	SCREW	1	1	1	1	
4	1C3-17411-10	AXLE, MAIN (13T)	1	1	1	1	
5	1C3-17161-10	GEAR, 6TH PINION (21T)	1	1	1	1	
6	90201-22555	WASHER, PLATE	1	1	1	1	
7	93410-22039	CIRCLIP	2	2	2	2	
8	1C3-17131-10	GEAR, 3RD PINION (17T/17T)	1	1	1	1	
9	90209-18135	WASHER	1	1	1	1	
10	1C3-17151-10	GEAR, 5TH PINION (20T)	1	1	1	1	
11	1C3-17121-10	GEAR, 2ND PINION (15T)	1	1	1	1	
12	93306-20351	BEARING	1	1	1	1	
13	93306-00326	BEARING	1	1	1	1	
14	1C3-17421-00	AXLE, DRIVE	1	1	1	1	
15	1C3-17211-10	GEAR, 1ST WHEEL (31T)	1	1	1	1	
16	1C3-17261-10	GEAR, 6TH WHEEL (23T)	1	1	1	1	
17	93410-22039	CIRCLIP	1	1	1	1	
18	90209-20008	WASHER	1	1	1	1	
19	1C3-17241-10	GEAR, 4TH WHEEL (23T)	1	1	1	1	
20	1C3-17231-20	GEAR, 3RD WHEEL (27T)	1	1	1	1	
21	1C3-17251-10	GEAR, 5TH WHEEL (24T)	1	1	1	1	
22	93410-26067	CIRCLIP	1	1	1	1	
23	90209-23012	WASHER	1	1	1	1	
24	1C3-17221-10	GEAR, 2ND WHEEL (29T)	1	1	1	1	
25	93306-20447	BEARING	1	1	1	1	
26	4JT-15381-01	PLATE, BEARING COVER	2	2	2	2	
27	90149-06074	SCREW	2	2	2	2	

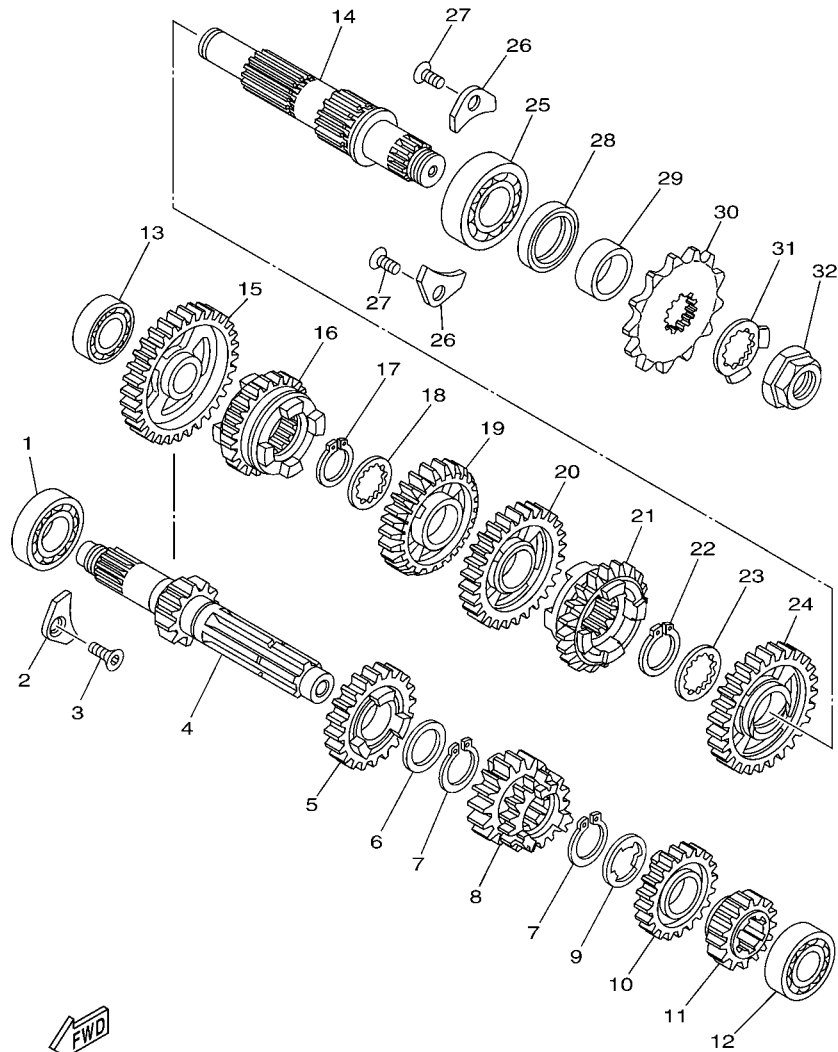

1C31100-D131

FIG. 13 TRANSMISSION

REF. NO.	PART NO.	DESCRIPTION	1SR9	1SFA	1SRB	1SRC	REMARKS
28	93102-28012	OIL SEAL	1	1	1	1	
29	90387-22004	COLLAR	1	1	1	1	
30	9383B-13218	SPROCKET, DRIVE (13T)	1	1	1	1	
31	90215-20003	WASHER, LOCK	1	1	1	1	
32	90179-18001	NUT	1	1	1	1	

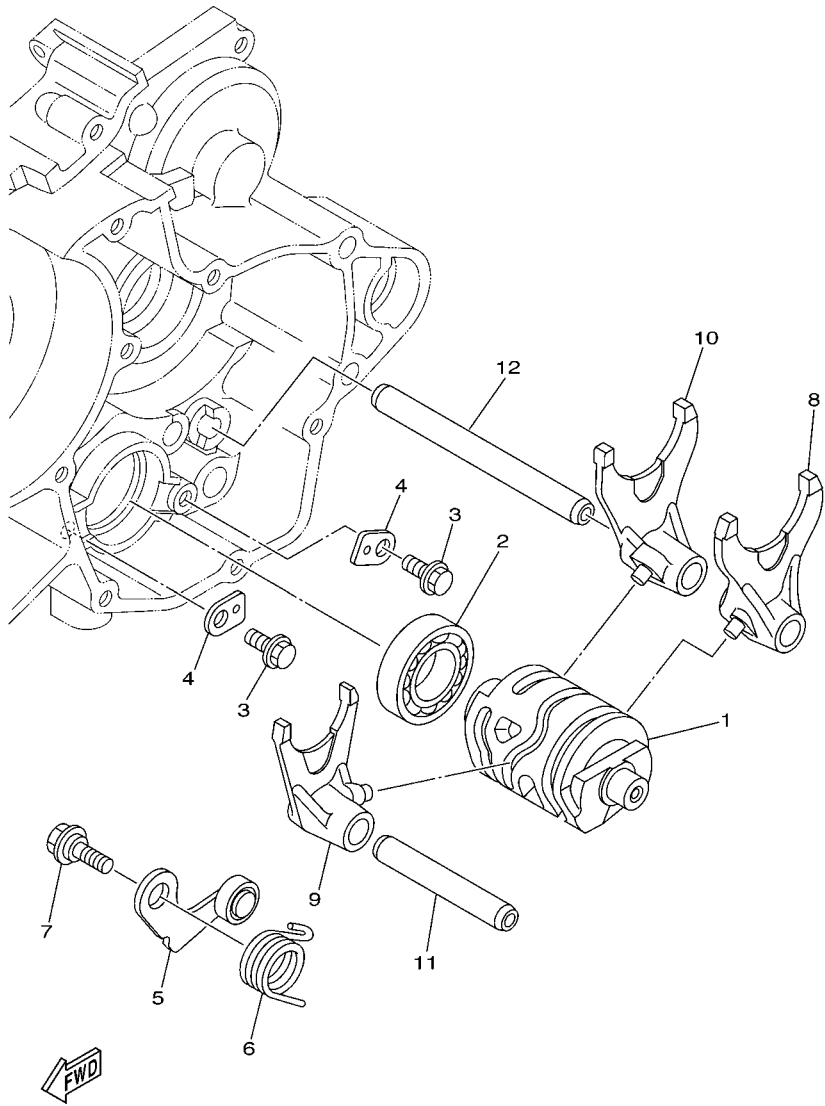

1C31100-D140

FIG. 14 SHIFT CAM & FORK

REF. NO.	PART NO.	DESCRIPTION	1SR9	1SFA	1SRB	1SRC	REMARKS
1	1C3-18541-00	CAM, SHIFT	1	1	1	1	
2	93306-90408	BEARING	1	1	1	1	
3	90105-06081	BOLT, FLANGE	2	2	2	2	
4	1C3-18562-00	PLATE, STOPPER 2	2	2	2	2	
5	1C3-18140-10	STOPPER LEVER ASSY	1	1	1	1	
6	90508-261B7	SPRING, TORSION	1	1	1	1	
7	90109-06193	BOLT	1	1	1	1	
8	1C3-18511-00	FORK, SHIFT 1	1	1	1	1	
9	1C3-18512-00	FORK, SHIFT 2	1	1	1	1	
10	1C3-18513-00	FORK, SHIFT 3	1	1	1	1	
11	3XV-18531-00	BAR, SHIFT FORK GUIDE 1	1	1	1	1	
12	4JG-18531-00	BAR, SHIFT FORK GUIDE 1	1	1	1	1	

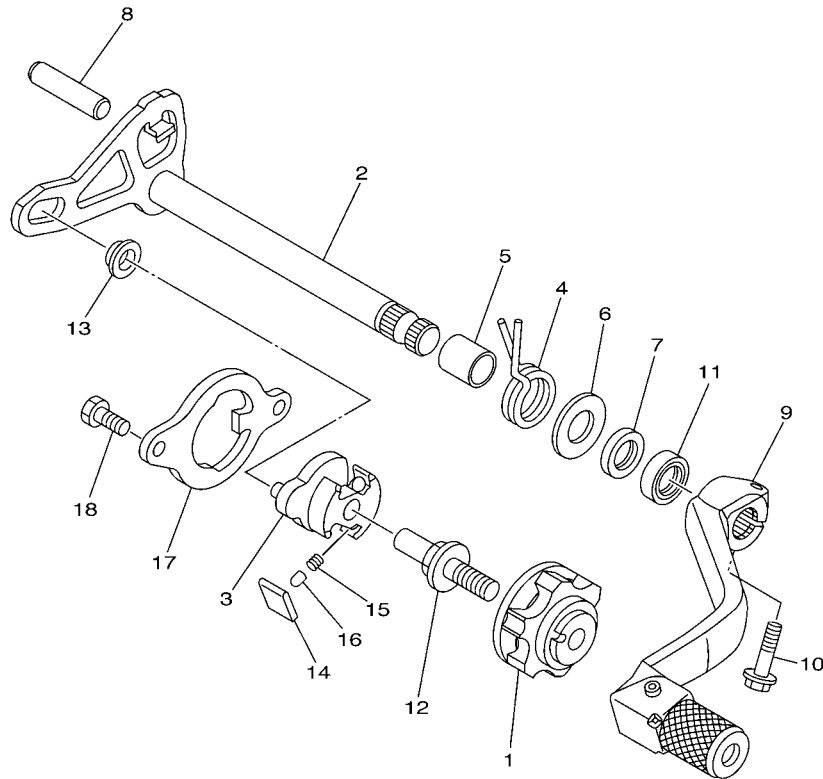

1C31100-D150

FIG. 15 SHIFT SHAFT

REF. NO.	PART NO.	DESCRIPTION	1SR9	1SFA	1SRB	1SRC	REMARKS
1	1C3-18185-00	SEGMENT	1	1	1	1	
2	1C3-18101-00	SHIFT SHAFT ASSY	1	1	1	1	
3	5LP-18122-01	LEVER, SHIFT 2	1	1	1	1	
4	90508-29020	SPRING, TORSION	1	1	1	1	
5	90560-12280	SPACER	1	1	1	1	
6	90201-12020	WASHER, PLATE	1	1	1	1	
7	93104-12003	OIL SEAL	1	1	1	1	
8	93608-33002	PIN, DOWEL	1	1	1	1	
9	1C3-18110-00	SHIFT PEDAL ASSY	1	1	1	1	
10	95022-06020	BOLT, FLANGE	1	1	1	1	
11	93102-12224	OIL SEAL	1	1	1	1	
12	3XJ-18173-10	PIN, SHIFT	1	1	1	1	
13	3XJ-18178-00	ROLLER, SHIFT LEVER	1	1	1	1	
14	3XJ-18182-00	PAWL, SHIFTER	2	2	2	2	
15	90501-052G5	SPRING, COMPRESSION	2	2	2	2	
16	3XJ-18184-00	PIN, PAWL	2	2	2	2	
17	1C3-18172-00	GUIDE, SHIFT	1	1	1	1	
18	90101-06041	BOLT	2	2	2	2	

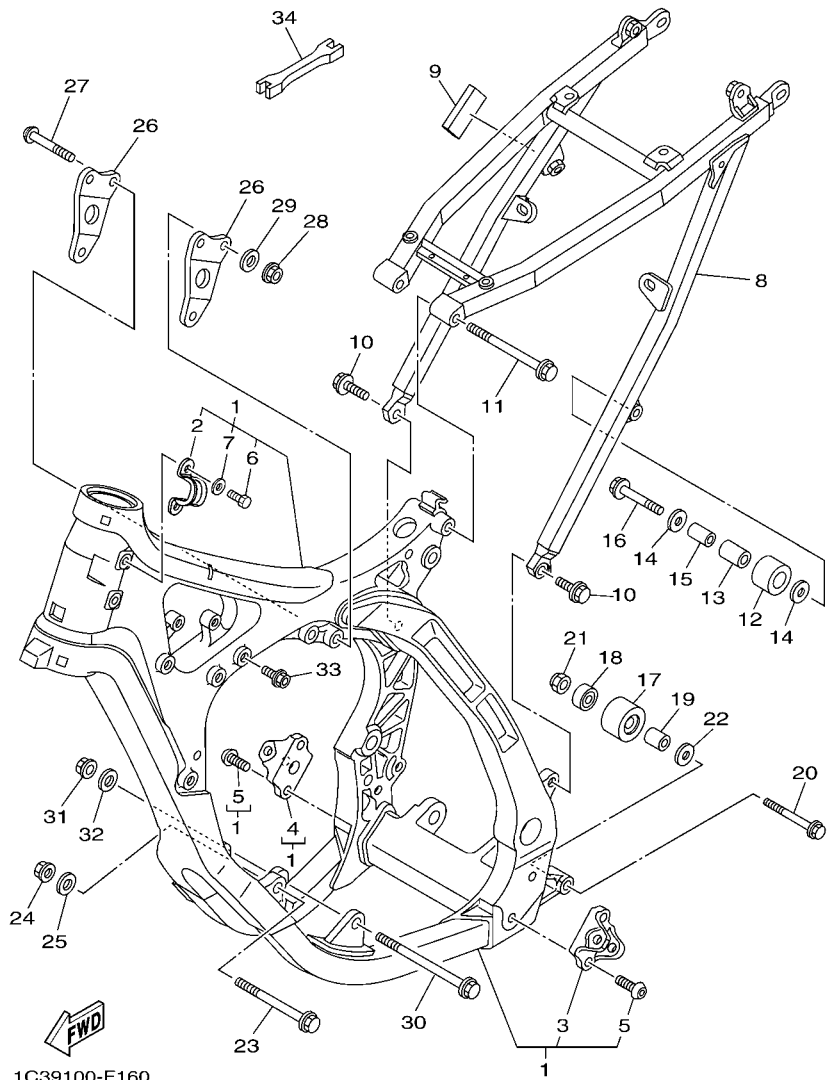
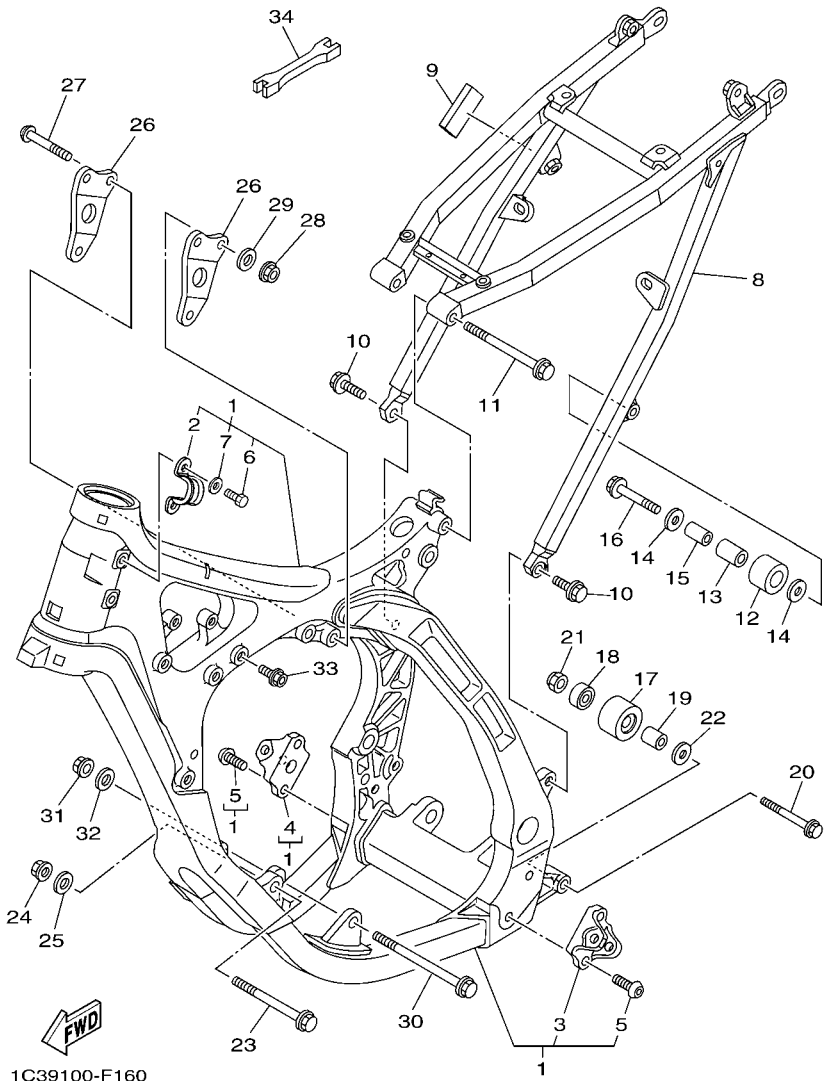

FIG. 16 FRAME

REF. NO.	PART NO.	DESCRIPTION	1SR9	1SFA	1SRB	1SRC	REMARKS
1	1C3-21101-50	FRONT FRAME COMP.	1	1	1	1	
2	1C3-21336-00	.CLAMP, WIRE HARNESS 2	1	1	1	1	
3	1C3-21447-10	.BRACKET, FOOTREST	1	1	1	1	
4	1C3-21448-10	.BRACKET, FOOTREST	1	1	1	1	
5	90149-10031	.SCREW	4	4	4	4	
6	97004-05012	.BOLT	2	2	2	2	
7	92904-05600	.WASHER	2	2	2	2	
8	1C3-21190-90	REAR FRAME COMP.	1	1	1	1	
9	5GJ-21717-00	DAMPER	1	1	1	1	
10	90105-08085	BOLT, FLANGE	2	2	2	2	
11	90105-08132	BOLT, FLANGE	1	1	1	1	
12	30X-22178-00	TENSIONER	1	1	1	1	
13	4V4-22184-00	BUSH	1	1	1	1	
14	90201-08045	WASHER, PLATE	2	2	2	2	
15	90387-08041	COLLAR	1	1	1	1	
16	95022-08040	BOLT, FLANGE	1	1	1	1	
17	3JD-22178-20	TENSIONER	1	1	1	1	
18	93300-60839	BEARING	1	1	1	1	
19	90387-086N4	COLLAR	1	1	1	1	
20	90105-08133	BOLT, FLANGE	1	1	1	1	
21	90185-08009	NUT, SELF-LOCKING	1	1	1	1	
22	90201-08043	WASHER, PLATE	1	1	1	1	
23	90105-10175	BOLT, FLANGE	1	1	1	1	
24	90179-10658	NUT	1	1	1	1	
25	92902-10200	WASHER	1	1	1	1	
26	1C3-21425-00	BRACKET, REAR UPPER 1	2	2	2	2	
27	90111-08028	BOLT,HEX. SOCKET BUTTON	3	3	3	3	



1C39100-F160

FIG. 16 FRAME

REF. NO.	PART NO.	DESCRIPTION	1SR9	1SFA	1SRB	1SRC	REMARKS
28	90179-08674	NUT	3	3	3	3	
29	90201-08055	WASHER, PLATE	3	3	3	3	
30	90105-10176	BOLT, FLANGE	1	1	1	1	
31	90179-10658	NUT	1	1	1	1	
32	92902-10200	WASHER	1	1	1	1	
33	1C3-21244-10	NUT	2	2	2	2	
34	5ET-28166-10	WRENCH, HEXAGON	1	1	1	1	
<hr/>							
<hr/>							
<hr/>							
<hr/>							
<hr/>							
<hr/>							
<hr/>							
<hr/>							
<hr/>							
<hr/>							

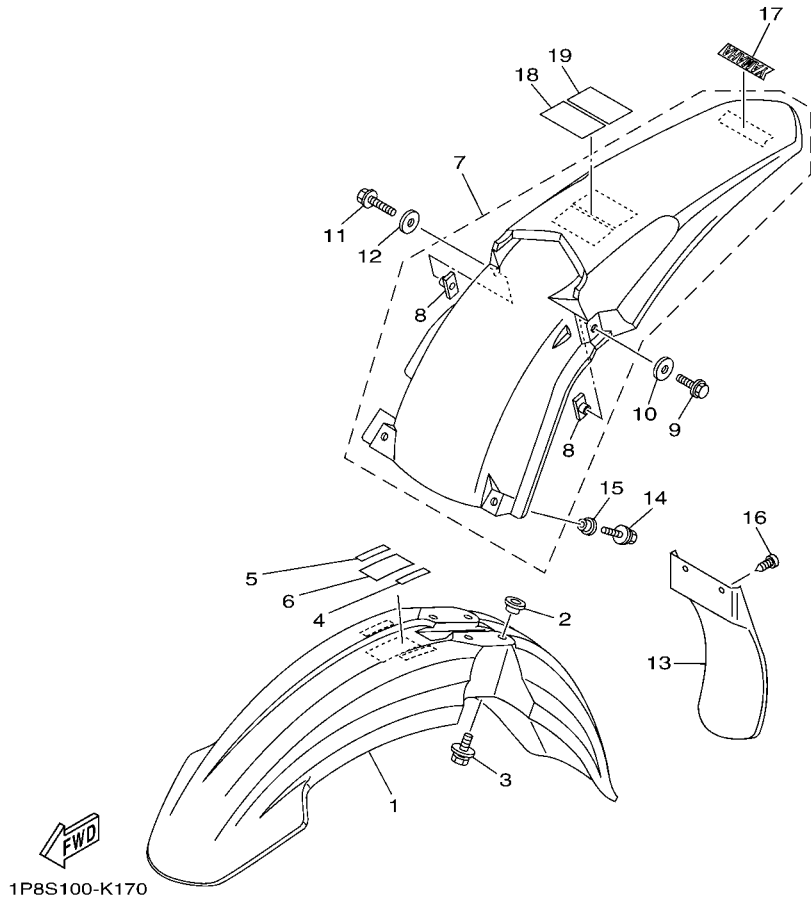
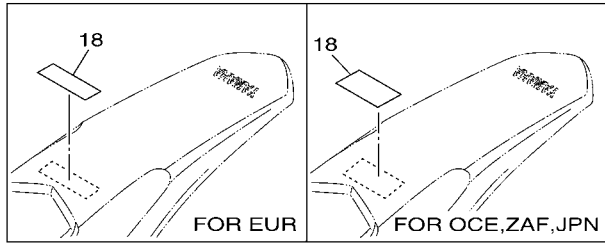
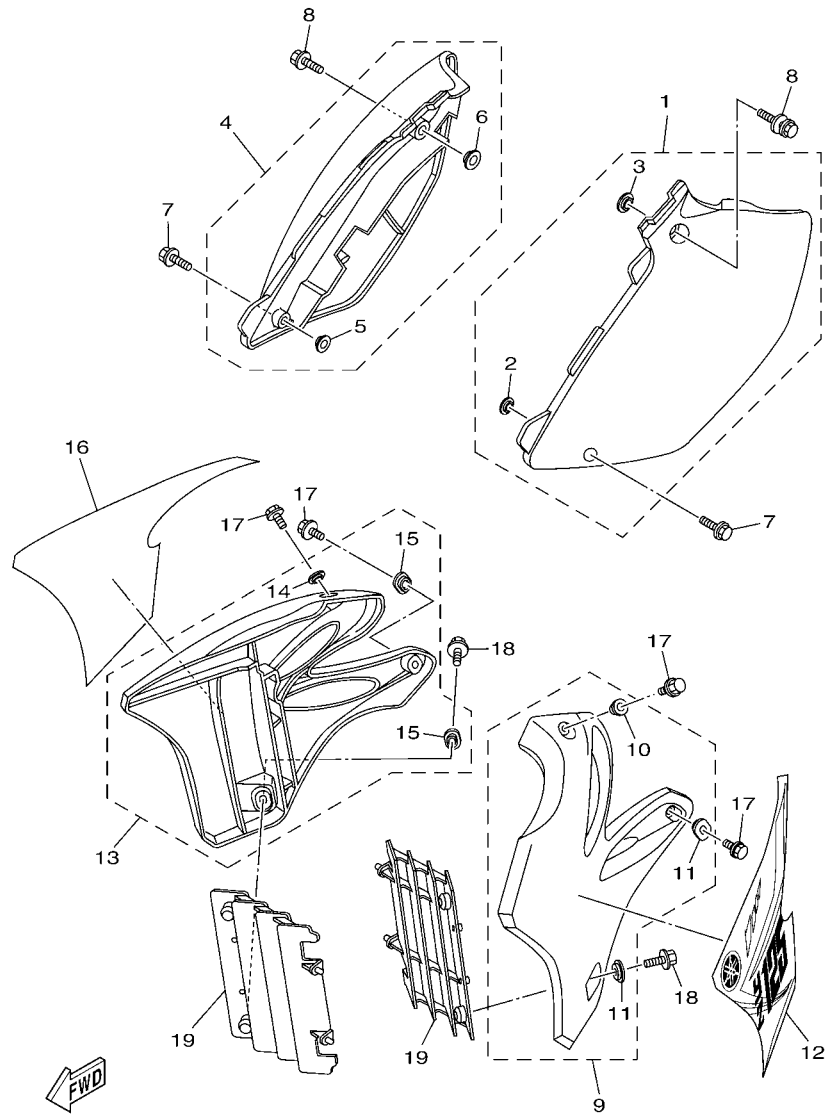

FIG. 17 FENDER

REF. NO.	PART NO.	DESCRIPTION	1SR9	1SFA	1SRB	1SRC	REMARKS
1	1C3-21511-51	FENDER, FRONT	1	1	1	1	
2	90387-06090	COLLAR	4	4	4	4	
3	90119-06147	BOLT, WITH WASHER	4	4	4	4	
4	3XJ-2415E-A1	LABEL, CAUTION	1				
	3XJ-2415E-C1	LABEL, CAUTION			1		
5	3XJ-2415E-B1	LABEL, CAUTION	1				
6	4SR-2416E-00	LABEL, CAUTION CANADA	1				
7	5XE-21610-20	REAR FENDER COMP.	1	1	1	1	
8	5XE-21635-10	.NUT, REAR FENDER	2	2	2	2	
9	90105-06099	BOLT, FLANGE	1	1	1	1	
10	90201-06032	WASHER, PLATE	1	1	1	1	
11	90105-06101	BOLT, FLANGE	1	1	1	1	
12	90201-06033	WASHER, PLATE	1	1	1	1	
13	5TA-21642-00	GUARD, FLAP	1	1	1	1	
14	90119-06149	BOLT, WITH WASHER	2	2	2	2	
15	90387-06009	COLLAR	2	2	2	2	
16	97702-60016	SCREW, TAPPING	2	2	2	2	
17	4ES-2153E-20	EMBLEM, YAMAHA	1	1	1	1	
18	5PA-2118K-00	LABEL, CAUTION	1			1	
	5PG-2816R-00	LABEL, WARNING GENERAL INFO.			1		
	5PA-2118K-20	LABEL, CAUTION				1	
19	5PA-2118K-10	LABEL, CAUTION	1				



1SR9110-N180

FIG. 18 SIDE COVER

REF. NO.	PART NO.	DESCRIPTION	1SR9	1SRA	1SRB	1SRC	REMARKS
1	5NY-21711-00	COVER, SIDE 1	1	1	1	1	
2	90387-06009	.COLLAR	1	1	1	1	
3	5BE-21749-00	.COLLAR	1	1	1	1	
4	1C3-21721-50	COVER, SIDE 2	1	1	1	1	
5	90387-06009	.COLLAR	1	1	1	1	
6	5BE-21749-00	.COLLAR	1	1	1	1	
7	90105-06103	BOLT, FLANGE	2	2	2	2	
8	90119-08095	BOLT, WITH WASHER	2	2	2	2	
9	5XE-21730-00	SIDE COVER ASSY 3	1	1	1	1	
10	90387-06009	.COLLAR	1	1	1	1	
11	5TA-21749-00	.COLLAR	2	2	2	2	
12	1SR-2173E-20	GRAPHIC 1	1	1	1	1	
13	5XE-21740-00	SIDE COVER ASSY 4	1	1	1	1	
14	90387-06009	.COLLAR	1	1	1	1	
15	5TA-21749-00	.COLLAR	2	2	2	2	
16	1SR-2173F-20	GRAPHIC 2	1	1	1	1	
17	90105-06064	BOLT, FLANGE	4	4	4	4	
18	90159-06021	SCREW, WITH WASHER	2	2	2	2	
19	5NL-2172A-20	PANEL 1	2	2	2	2	

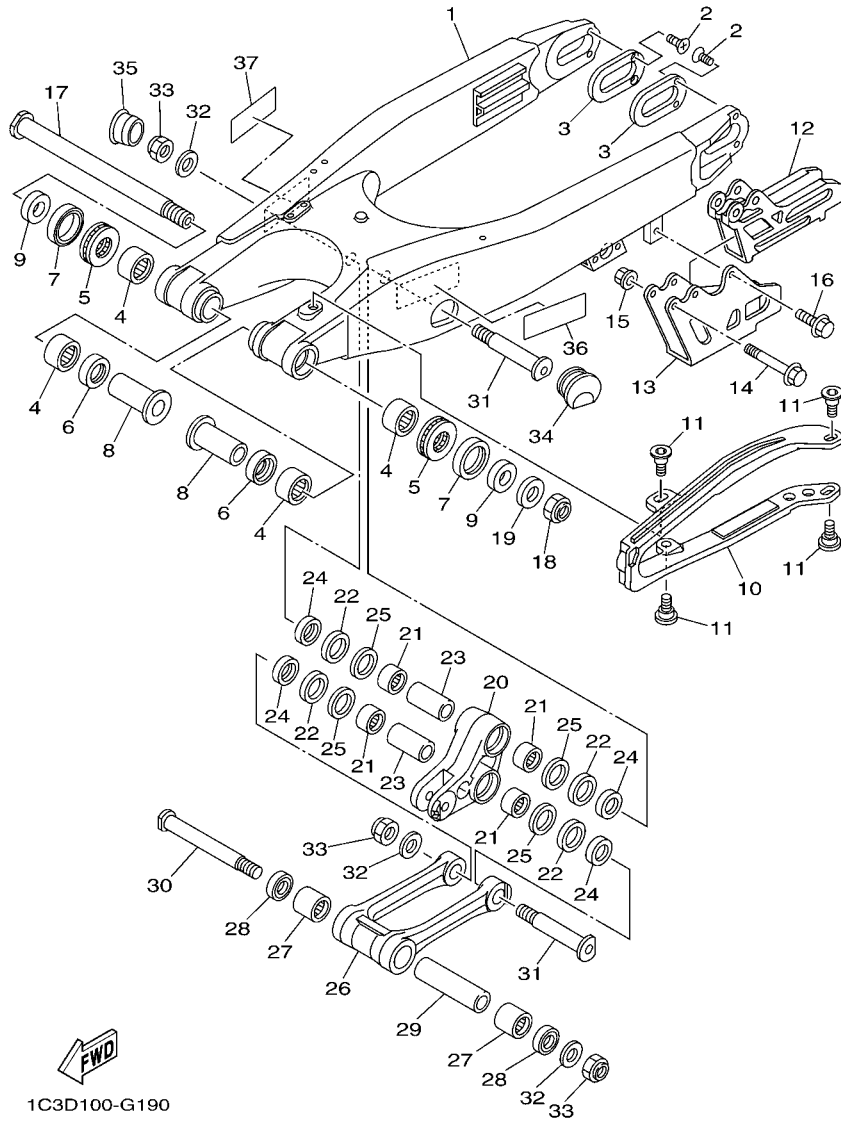

1C3D100-G190

FIG. 19 REAR ARM

REF. NO.	PART NO.	DESCRIPTION	1SR9	1SFA	1SRB	1SRC	REMARKS
1	1C3-22110-90	REAR ARM COMP.	1	1	1	1	
2	90151-04003	SCREW, COUNTERSUNK	4	4	4	4	
3	1C3-22355-00	PATCH	2	2	2	2	
4	93317-22262	BEARING	4	4	4	4	
5	93342-22217	BEARING	2	2	2	2	
6	93106-22002	OIL SEAL	2	2	2	2	
7	93109-28043	OIL SEAL	2	2	2	2	
8	90387-18010	COLLAR	2	2	2	2	
9	90387-18012	COLLAR	2	2	2	2	
10	2S2-22151-70	SEAL, GUARD	1	1	1	1	
11	1C3-22969-90	SCREW, 1	4	4	4	4	
12	2S2-22199-70	SUPPORT, CHAIN	1	1	1	1	
13	2S2-22128-70	COVER, THRUST 1	1	1	1	1	
14	90105-06104	BOLT, FLANGE	2	2	2	2	
15	90179-06028	NUT	2	2	2	2	
16	90105-06105	BOLT, FLANGE	1	1	1	1	
17	1C3-22141-10	SHAFT, PIVOT	1	1	1	1	
18	90185-16002	NUT, SELF-LOCKING	1	1	1	1	
19	90201-16018	WASHER, PLATE	1	1	1	1	
20	1C3-2217A-00	ARM, RELAY	1	1	1	1	
21	93315-32166	BEARING	4	4	4	4	
22	93109-25001	OIL SEAL	4	4	4	4	
23	90387-16025	COLLAR	2	2	2	2	
24	90209-16011	WASHER	4	4	4	4	
25	90201-21014	WASHER, PLATE	4	4	4	4	
26	1C3-2217F-50	ROD, CONNECTING 1	1	1	1	1	
27	93315-32166	BEARING	2	2	2	2	

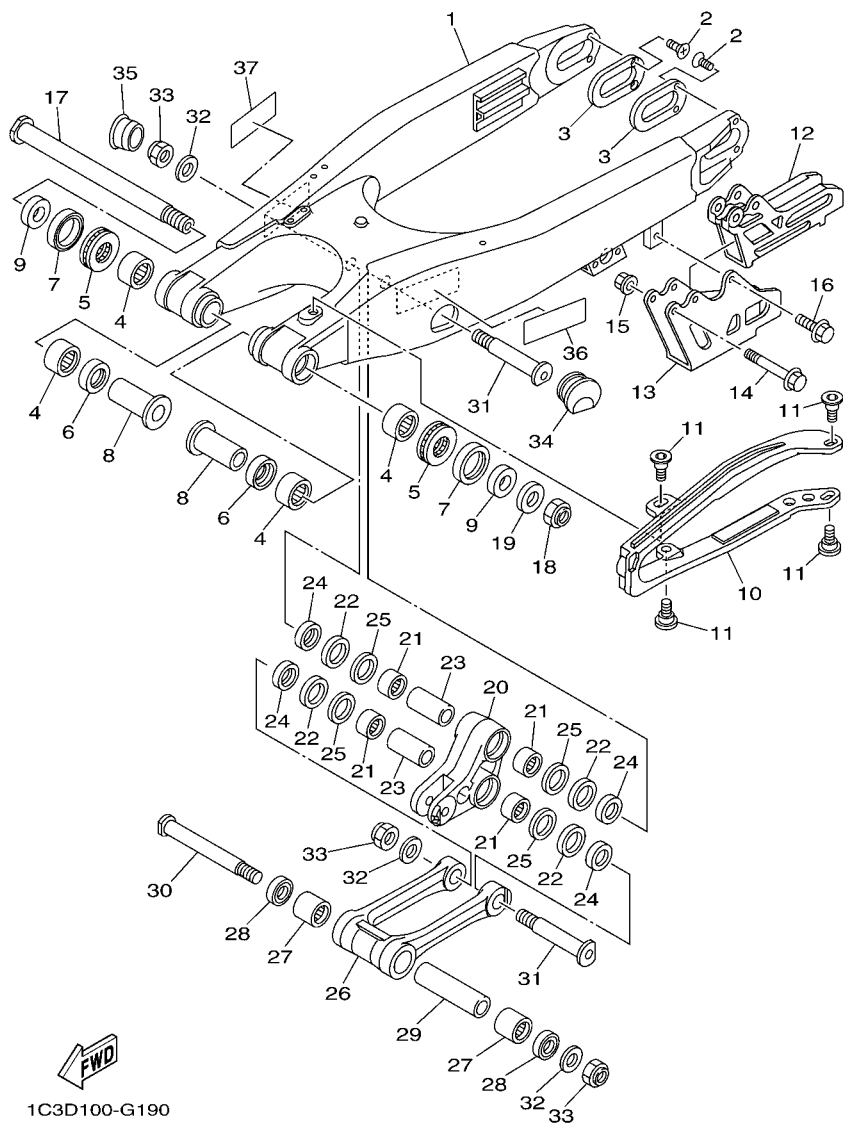
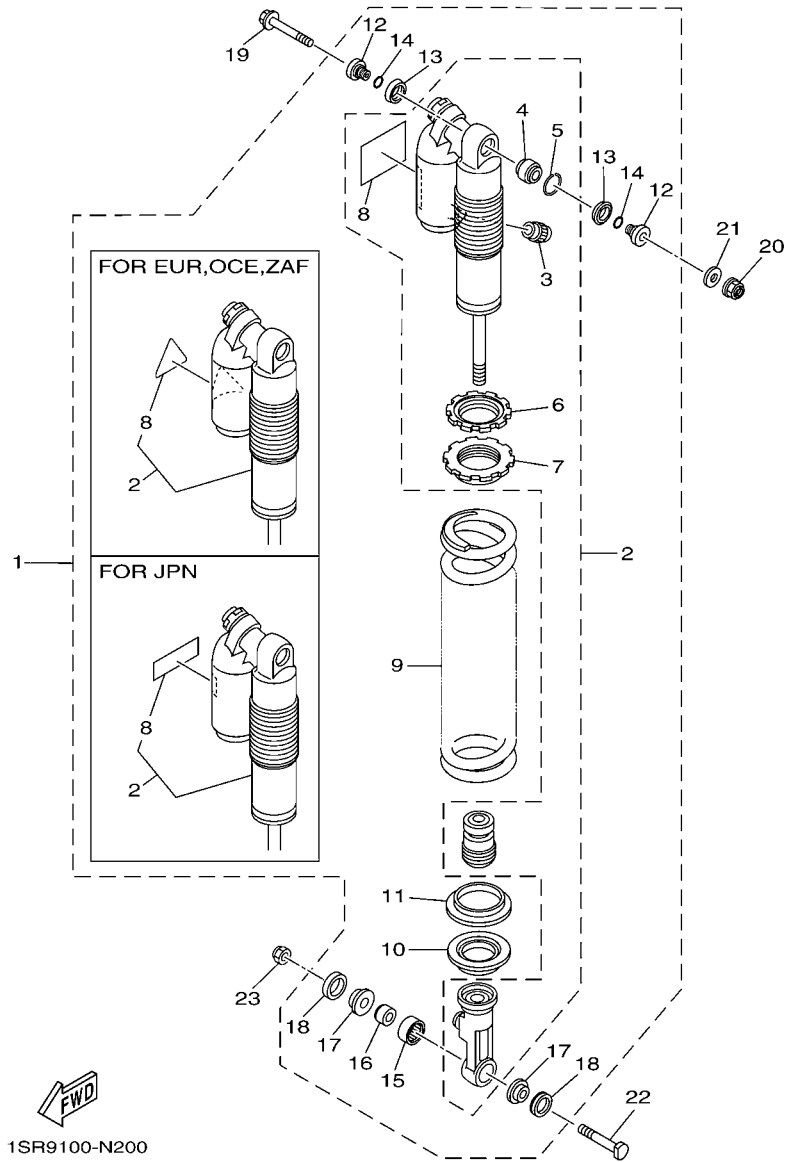

FIG. 19 REAR ARM

REF. NO.	PART NO.	DESCRIPTION	1SR9	1SFA	1SRB	1SRC	REMARKS
28	93109-21001	OIL SEAL	2	2	2	2	
29	90387-14016	COLLAR	1	1	1	1	
30	1C3-22121-00	SHAFT 1	1	1	1	1	
31	1C3-22122-00	SHAFT 2	2	2	2	2	
32	90201-14020	WASHER, PLATE	3	3	3	3	
33	90185-14010	NUT, SELF-LOCKING	3	3	3	3	
34	1C3-2135F-00	COVER	1	1	1	1	
35	1C3-2139R-00	COVER 2	1	1	1	1	
36	3RV-21668-A0	LABEL, TIRE	1			1	
37	3RV-21668-B0	LABEL, TIRE	1				



1SR9100-N200

FIG. 20 REAR SUSPENSION

REF. NO.	PART NO.	DESCRIPTION	1SR9	1SRA	1SRB	1SRC	REMARKS
1	1SR-22200-10	SHOCK ABSORBER ASSY, REAR	1				
	1SR-22200-20	SHOCK ABSORBER ASSY, REAR		1		1	
	1SR-22200-30	SHOCK ABSORBER ASSY, REAR			1		
2	1C3-22201-K0	.DAMPER SUB ASSY	1				
	1C3-22201-J0	.DAMPER SUB ASSY		1		1	
	1C3-22201-H0	.DAMPER SUB ASSY			1		
3	509-23184-L0	..CAP, AIR VALVE	1	1	1	1	
4	4JX-22226-00	..BUSH, SHOCK ABSORBER LOWER	1	1	1	1	
5	5DH-23183-00	..CIRCLIP	1	1	1	1	
6	3SP-22234-00	..GUIDE, SPRING 3	1	1	1	1	
7	1C3-22213-L0	..SEAT, SPRING UPPER	1	1	1	1	
8	4AA-22259-60	..LABEL, WARNING	1				
	4AA-22259-40	..LABEL, WARNING		1		1	
	4AA-22259-50	..LABEL, WARNING			1		
9	5UN-22212-20	.SPRING (K=46N/MM)	1	1	1	1	
10	1C3-22214-50	..GUIDE, SPRING 1	1	1	1	1	
11	5MV-22224-00	..GUIDE, SPRING 2	1	1	1	1	
12	1C3-22253-50	..COLLAR, DISTANCE	2	2	2	2	
13	3JE-22475-00	..SEAL, DUST	2	2	2	2	
14	4EW-22474-00	..SEAL, RING	2	2	2	2	
15	5UN-22176-00	..BEARING	1	1	1	1	
16	5MV-22184-00	..BUSH	1	1	1	1	
17	1C3-22253-L1	..COLLAR, DISTANCE	2	2	2	2	
18	5NY-22475-00	..SEAL, DUST	2	2	2	2	
19	5XE-22242-00	BOLT 2	1	1	1	1	
20	95602-10200	NUT, U FLANGE	1	1	1	1	
21	92902-10200	WASHER	1	1	1	1	

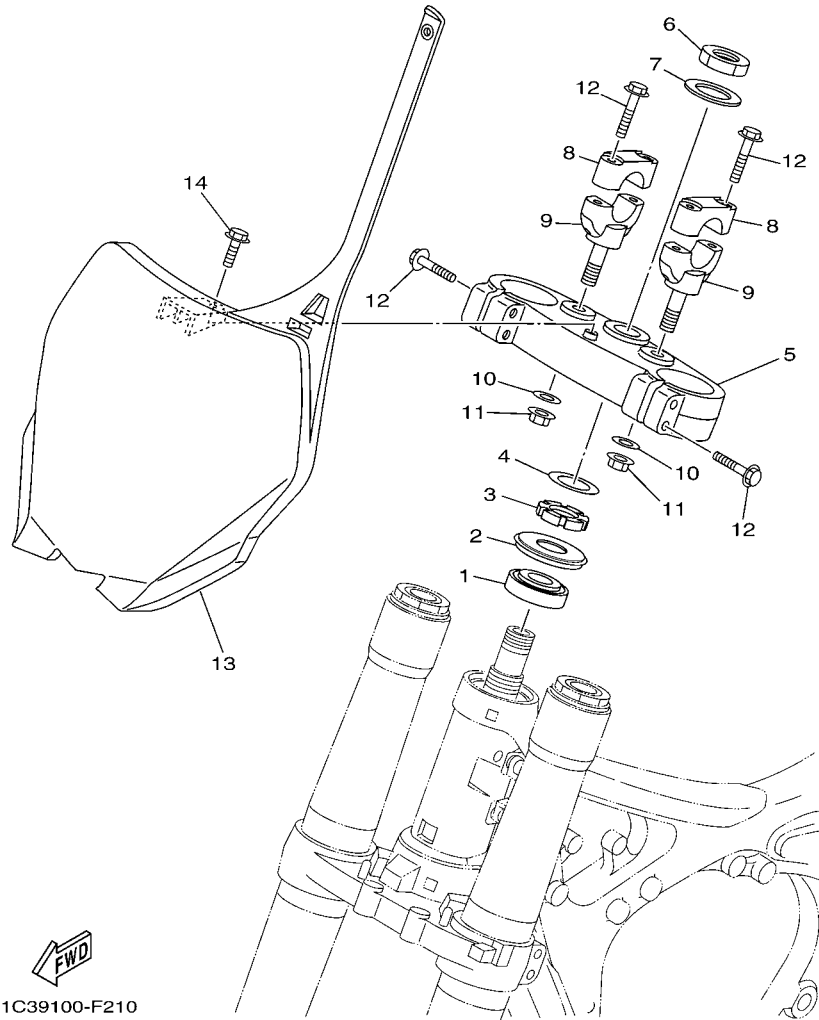

1C39100-F210

FIG. 21 STEERING

REF. NO.	PART NO.	DESCRIPTION	1SR9	1SFA	1SRB	1SRC	REMARKS
1	93332-00068	BEARING	1	1	1	1	
2	4EW-23416-00	COVER, BALL RACE 2	1	1	1	1	
3	90179-28013	NUT	1	1	1	1	
4	90201-286K9	WASHER, PLATE (T1.0)	1	1	1	1	
5	1C3-23435-50	CROWN, HANDLE	1	1	1	1	
6	90170-24003	NUT	1	1	1	1	
7	90201-24016	WASHER, PLATE	1	1	1	1	
8	5XC-23441-90	HOLDER, HANDLE UPPER	2	2	2	2	
9	5XC-23442-90	HOLDER, HANDLE LOWER	2	2	2	2	
10	90201-12028	WASHER, PLATE	2	2	2	2	
11	95602-12200	NUT, SELF-LOCKING	2	2	2	2	
12	90105-08134	BOLT, FLANGE	8	8	8	8	
13	1C3-23485-61	PLATE, NUMBER	1	1	1	1	
14	90119-06151	BOLT, WITH WASHER	1	1	1	1	

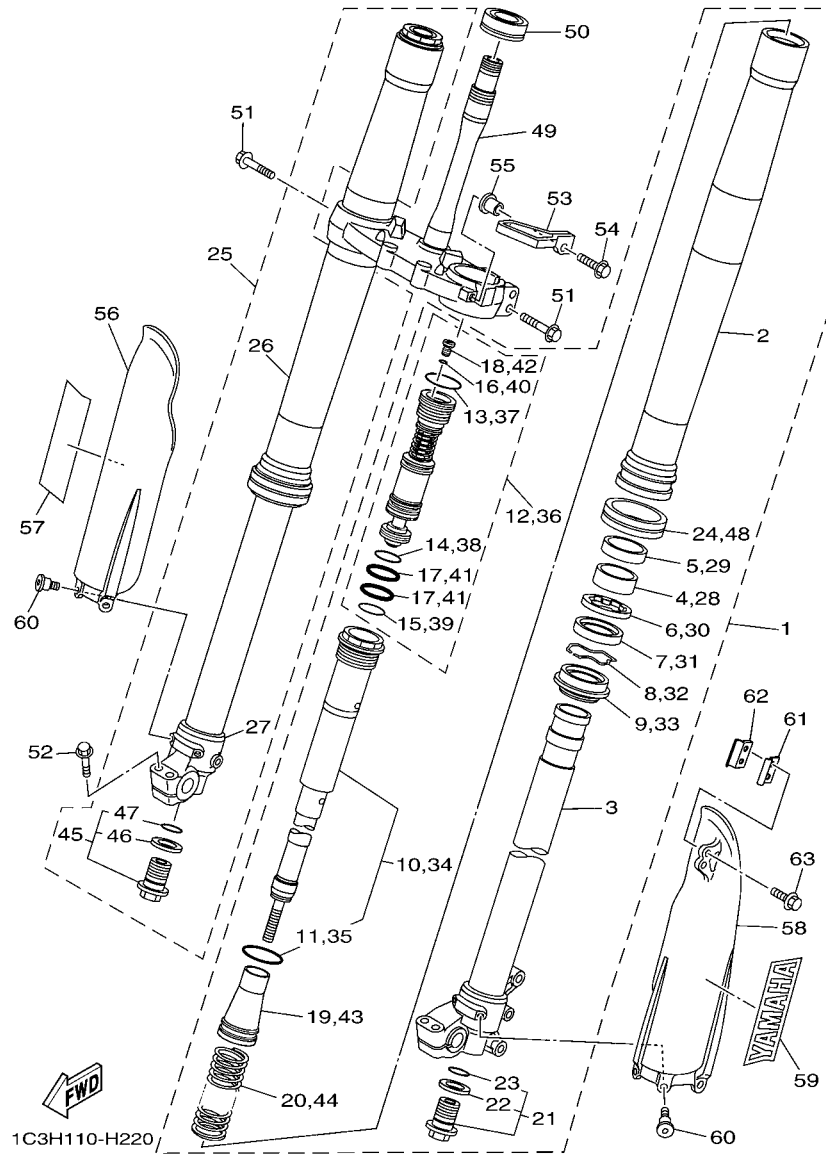

FIG. 22 FRONT FORK

REF. NO.	PART NO.	DESCRIPTION	1SR9	1SFA	1SRB	1SRC	REMARKS
1	1C3-23102-D0	FRONT FORK ASSY (L.H)	1		1	1	
	1C3-23102-E0	FRONT FORK ASSY (L.H)		1			
2	1C3-23136-P0	.TUBE, OUTER (R.H)	1	1	1	1	
3	5XC-23120-N0	.INNER TUBE COMP.2	1	1	1	1	
4	5XE-23171-L0	.PISTON, FRONT FORK	1	1	1	1	
5	5XE-23125-L0	.METAL, SLIDE 1	1	1	1	1	
6	5XC-23146-00	.WASHER, OIL SEAL	1	1	1	1	
7	1C3-23145-M0	.OIL SEAL	1	1	1	1	
8	5XE-23153-L0	.RING, SNAP	1	1	1	1	
9	5XE-23144-L0	.SEAL, DUST	1	1	1	1	
10	5XC-23170-P0	.CYLINDER COMP., FRONT FORK	1	1	1	1	
11	1C3-23147-L0	..O-RING	1	1	1	1	
12	1C3-2316A-T0	.VALVE COMP.	1		1	1	
	1C3-2316A-U0	.VALVE COMP.		1			
13	1C3-23188-L0	..O-RING	1	1	1	1	
14	1C3-23188-N0	..O-RING	1	1	1	1	
15	1C3-23188-P0	..O-RING	1	1	1	1	
16	1C3-23188-R0	..O-RING	1	1	1	1	
17	1AE-23147-00	..O-RING	2	2	2	2	
18	1C3-23190-L0	..AIR VALVE COMP.	1	1	1	1	
19	1C3-23142-L0	.SEAT, SPRING UPPER	1	1	1	1	
20	1C3-23141-P0	.SPRING, FRONT FORK(K=4.1N/MM)	1	1	1	1	
21	5XC-23111-00	.BOLT, CAP	1	1	1	1	
22	2HH-23158-L0	..GASKET	1	1	1	1	
23	276-23114-00	..GASKET	1	1	1	1	
24	5XC-2314F-00	.PROTECTOR GUIDE COMP., 1	1	1	1	1	
25	1C3-23103-D0	FRONT FORK ASSY (R.H)	1		1	1	

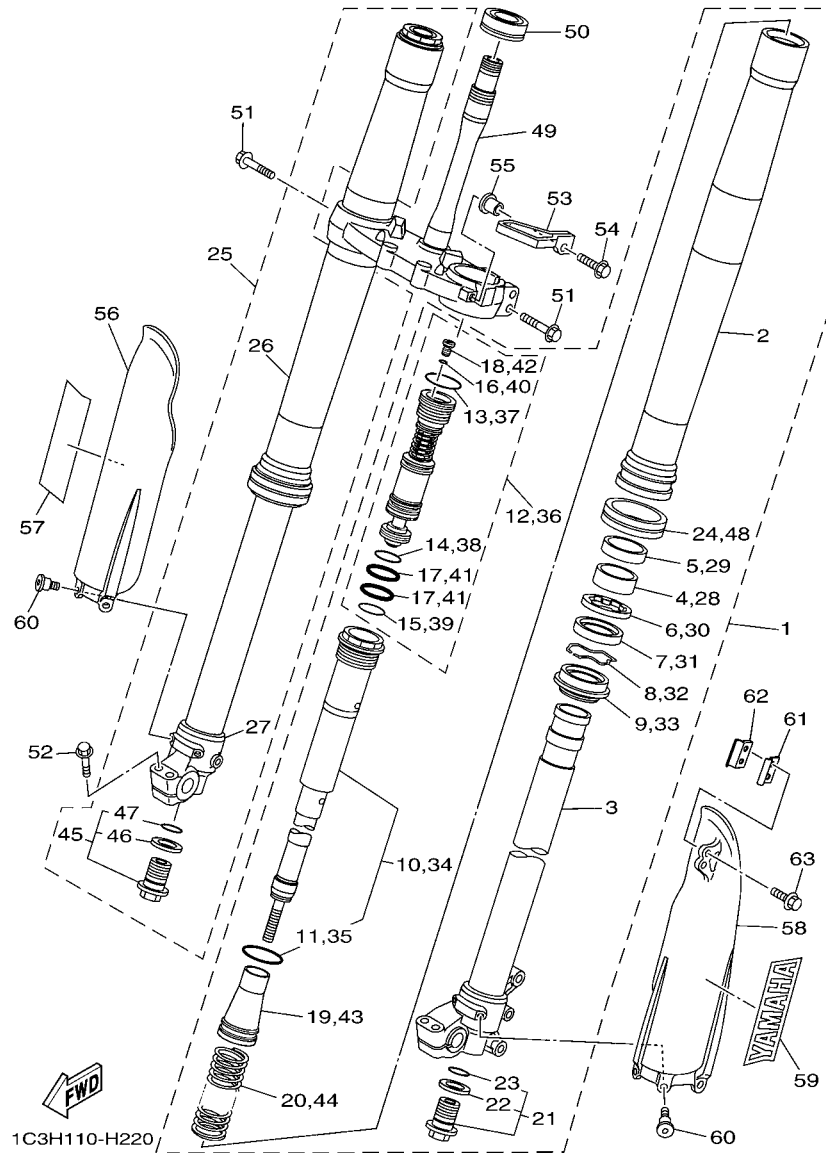

FIG. 22 FRONT FORK

REF. NO.	PART NO.	DESCRIPTION	1SR9	1SFA	1SRB	1SRC	REMARKS
25	1C3-23103-E0	FRONT FORK ASSY (R.H)		1			
26	1C3-23136-P0	.TUBE, OUTER (R.H)	1	1	1	1	
27	5XC-23110-N0	.INNER TUBE COMP.1	1	1	1	1	
28	5XE-23171-L0	.PISTON, FRONT FORK	1	1	1	1	
29	5XE-23125-L0	.METAL, SLIDE 1	1	1	1	1	
30	5XC-23146-00	.WASHER, OIL SEAL	1	1	1	1	
31	1C3-23145-M0	.OIL SEAL	1	1	1	1	
32	5XE-23153-L0	.RING, SNAP	1	1	1	1	
33	5XE-23144-L0	.SEAL, DUST	1	1	1	1	
34	5XC-23170-P0	.CYLINDER COMP., FRONT FORK	1	1	1	1	
35	1C3-23147-L0	..O-RING	1	1	1	1	
36	1C3-2316A-T0	.VALVE COMP.	1		1	1	
	1C3-2316A-U0	.VALVE COMP.		1			
37	1C3-23188-L0	..O-RING	1	1	1	1	
38	1C3-23188-N0	..O-RING	1	1	1	1	
39	1C3-23188-P0	..O-RING	1	1	1	1	
40	1C3-23188-R0	..O-RING	1	1	1	1	
41	1AE-23147-00	..O-RING	2	2	2	2	
42	1C3-23190-L0	..AIR VALVE COMP.	1	1	1	1	
43	1C3-23142-L0	.SEAT, SPRING UPPER	1	1	1	1	
44	1C3-23141-P0	.SPRING, FRONT FORK(K=4.1N/MM)	1	1	1	1	
45	5XC-23111-00	.BOLT, CAP	1	1	1	1	
46	2HH-23158-L0	..GASKET	1	1	1	1	
47	276-23114-00	..GASKET	1	1	1	1	
48	5XC-2314F-00	.PROTECTOR GUIDE COMP., 1	1	1	1	1	
49	1C3-23340-M0	UNDER BRACKET COMP.	1	1	1	1	
50	93332-00081	BEARING	1	1	1	1	

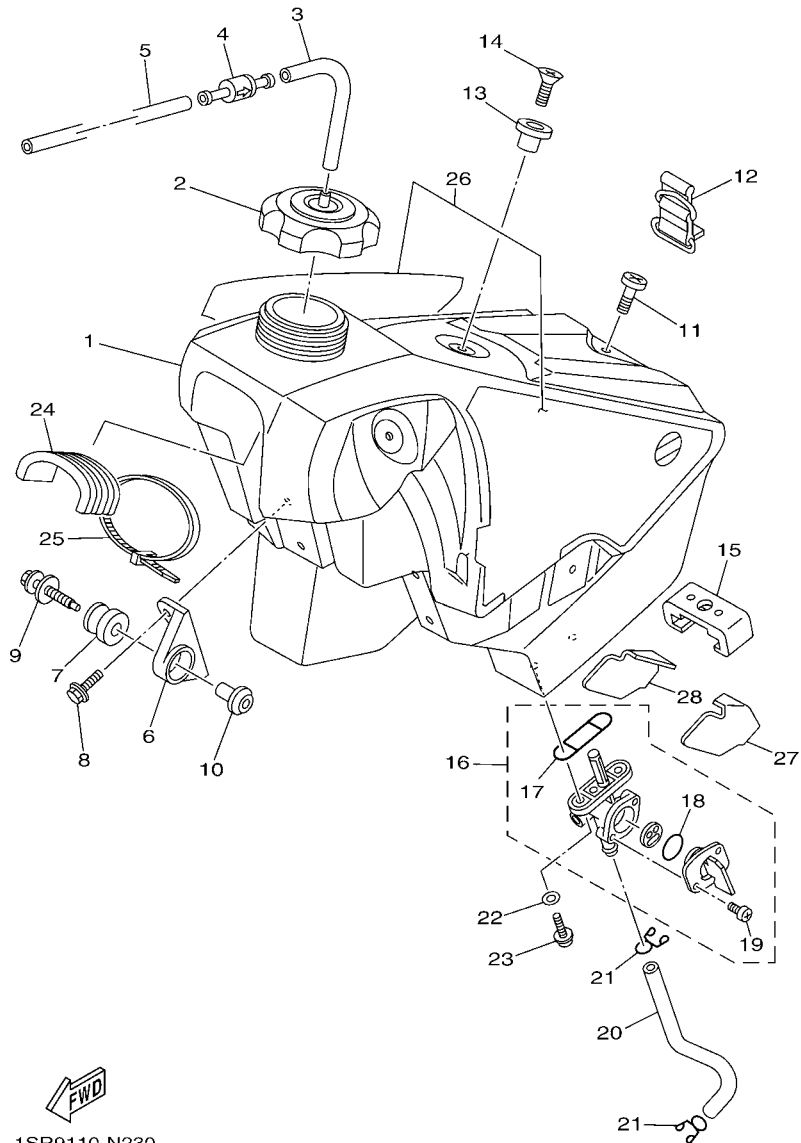

FIG. 23 FUEL TANK

REF. NO.	PART NO.	DESCRIPTION	1SR9	1SRA	1SRB	1SRC	REMARKS
1	1C3-24110-90	FUEL TANK COMP.	1	1	1	1	
2	5NY-24610-10	CAP ASSY	1	1	1	1	
3	90445-09003	HOSE (L30)	1	1	1	1	
4	3XJ-24380-00	PIPE JOINT ASSY	1	1	1	1	
5	90445-09005	HOSE	1	1	1	1	
6	5XE-24144-00	HOLDER, DAMPER	2	2	2	2	
7	90480-18549	GROMMET	2	2	2	2	
8	90105-06107	BOLT, FLANGE	4	4	4	4	
9	5XE-24176-10	BOLT 1	2	2	2	2	
10	5NY-24186-00	WASHER, SPECIAL	2	2	2	2	
11	98902-06025	SCREW, BIND	1	1	1	1	
12	3SP-24173-00	BAND, TANK FITTING 1	1	1	1	1	
13	4EW-2412F-00	BRACKET, SEAT	1	1	1	1	
14	98702-06025	SCREW, FLAT HEAD	1	1	1	1	
15	1C3-24181-00	DAMPER, LOCATING 1	1	1	1	1	
16	3JD-24500-20	FUEL COCK ASSY 1	1	1	1	1	
17	4X8-24512-10	.GASKET	1	1	1	1	
18	3AJ-24534-10	.SEAL, COCK	1	1	1	1	
19	98502-03008	.SCREW, PAN HEAD	2	2	2	2	
20	90445-111J0	HOSE (L145)	1	1	1	1	
21	90467-100A1	CLIP	2	2	2	2	
22	90202-05193	WASHER, PLATE	2	2	2	2	
23	90149-06108	SCREW	2	2	2	2	
24	1C3-24182-00	DAMPER, LOCATING 2	1	1	1	1	
25	90465-13275	CLAMP	1	1	1	1	
26	1SR-24240-20	GRAPHIC SET	1	1	1	1	
27	1C3-24183-00	DAMPER, LOCATING 3	1	1	1	1	

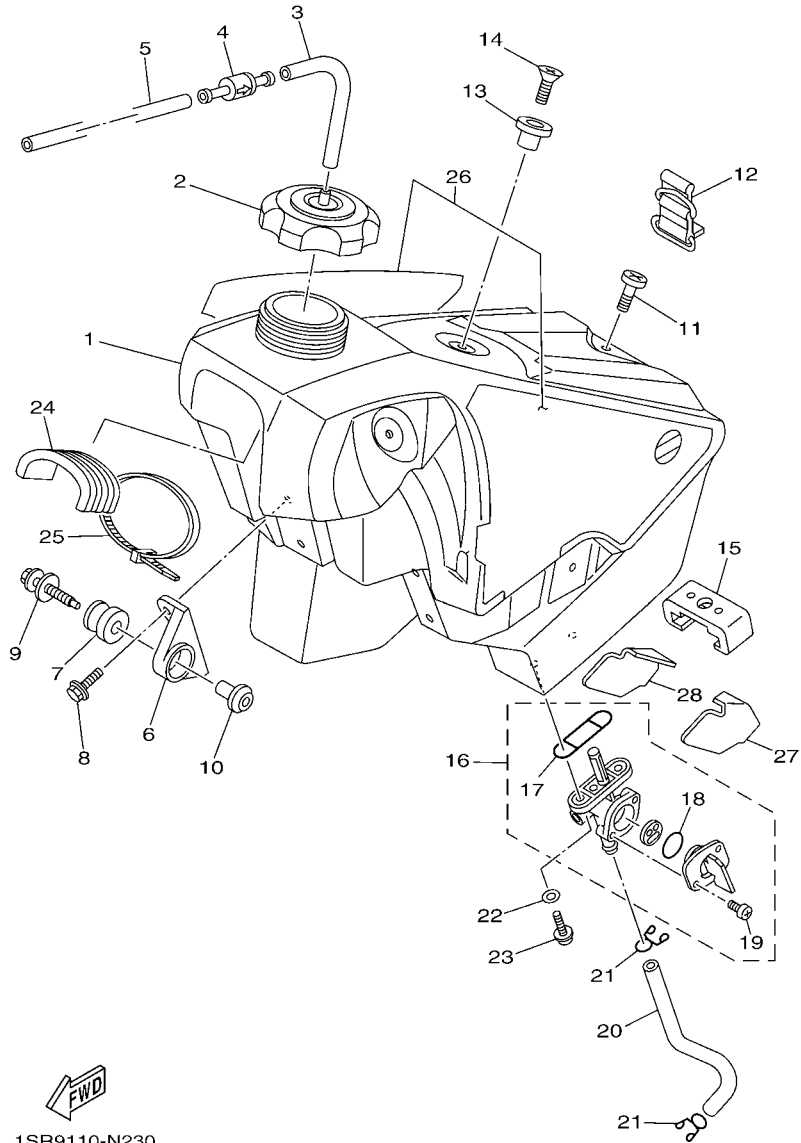
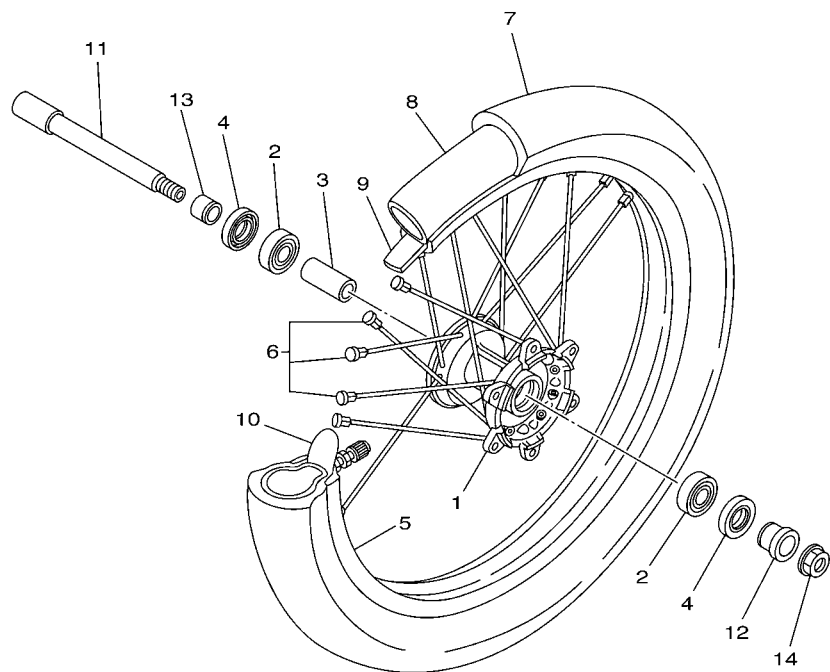

FIG. 23 FUEL TANK

REF. NO.	PART NO.	DESCRIPTION	1SR9	1SFA	1SRB	1SRC	REMARKS
28	1C3-24184-00	DAMPER, LOCATING 4	1	1	1	1	

FIG. 25 FRONT WHEEL



REF. NO.	PART NO.	DESCRIPTION	1SR9	1SFA	1SRB	1SRC	REMARKS
1	5NY-25111-00	HUB, FRONT	1	1	1	1	
2	93306-90409	BEARING	2	2	2	2	
3	5NY-25117-00	SPACER, BEARING	1	1	1	1	
4	93102-26468	OIL SEAL	2	2	2	2	
5	94416-21005	RIM (1.60-21)	1	1	1	1	
6	5NY-25104-00	SPOKE SET, FRONT	1	1	1	1	
7	94108-2112Y	TIRE (80/100-21 51M D755F)	1	1			DUNLOP
	94108-21012	TIRE(80/100-21 51M M601)			1		BRIDGESTONE
	94108-21025	TIRE (80/100-21 51M D742FA)				1	DUNLOP
8	94227-21101	TUBE (80/100-21 M/C TR4)	1	1		1	DUNLOP
	94209-21229	TUBE (80/100-21 M/C TR4)				1	BRIDGESTONE
9	94309-21161	BAND, RIM (22-21)	1	1		1	DUNLOP
	94330-21084	BAND,RIM (1.60-21)				1	BRIDGESTONE
10	5SF-25394-00	SPACER, BEAD	1	1	1	1	
11	5XC-25181-G0	AXLE, WHEEL	1	1	1	1	
12	5XC-25183-G0	COLLAR, WHEEL	1	1	1	1	
13	5XC-25186-G0	COLLAR, WHEEL	1	1	1	1	
14	90179-16011	NUT	1	1	1	1	



1C31100-D250

FIG. 26 FRONT BRAKE CALIPER

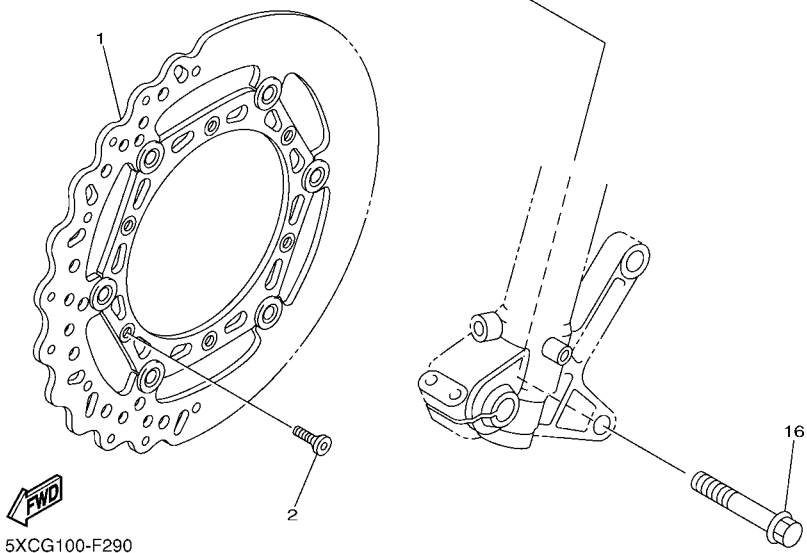
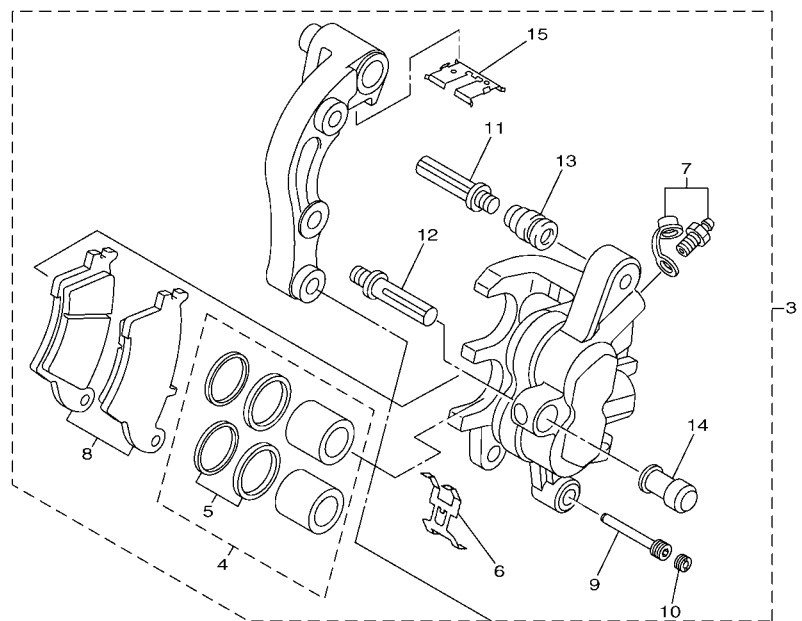

REF. NO.	PART NO.	DESCRIPTION	1SR9	1SFA	1SRB	1SRC	REMARKS
1	5XC-2581T-G0	DISK BRAKE ASSY	1	1	1	1	
2	90151-06051	SCREW, COUNTERSUNK	6	6	6	6	
3	5XC-2580T-G0	CALIPER ASSY (LEFT)	1	1	1	1	
4	5XC-W0057-00	.PISTON ASSY, CALIPER	1	1	1	1	
5	5KM-W0047-10	..CALIPER SEAL KIT	1	1	1	1	
6	5DH-25919-00	.SUPPORT, PAD	1	1	1	1	
7	1UY-W0048-50	.BLEED SCREW KIT	1	1	1	1	
8	5XC-W0045-00	.BRAKE PAD KIT	1	1	1	1	
9	5DH-25933-00	.PIN, PAD	1	1	1	1	
10	5DH-25916-00	.PLUG	1	1	1	1	
11	3SP-25926-51	.BOLT	1	1	1	1	
12	3SP-25914-51	.PIN, SLIDE	1	1	1	1	
13	3JD-25917-00	.BOOT, CALIPER	1	1	1	1	
14	1UY-25937-51	.BOOT 2	1	1	1	1	
15	5XC-25849-G0	.RETAINER, CALIPER	1	1	1	1	
16	90105-08137	BOLT, FLANGE	2	2	2	2	

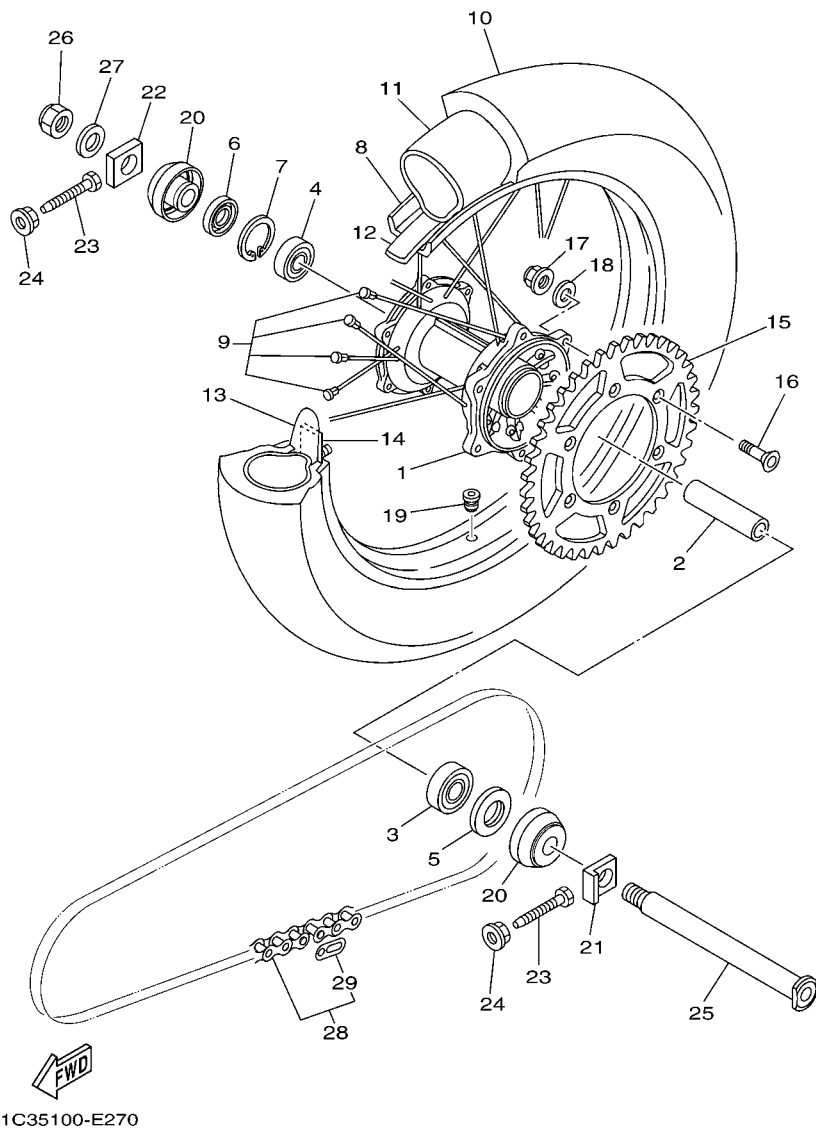
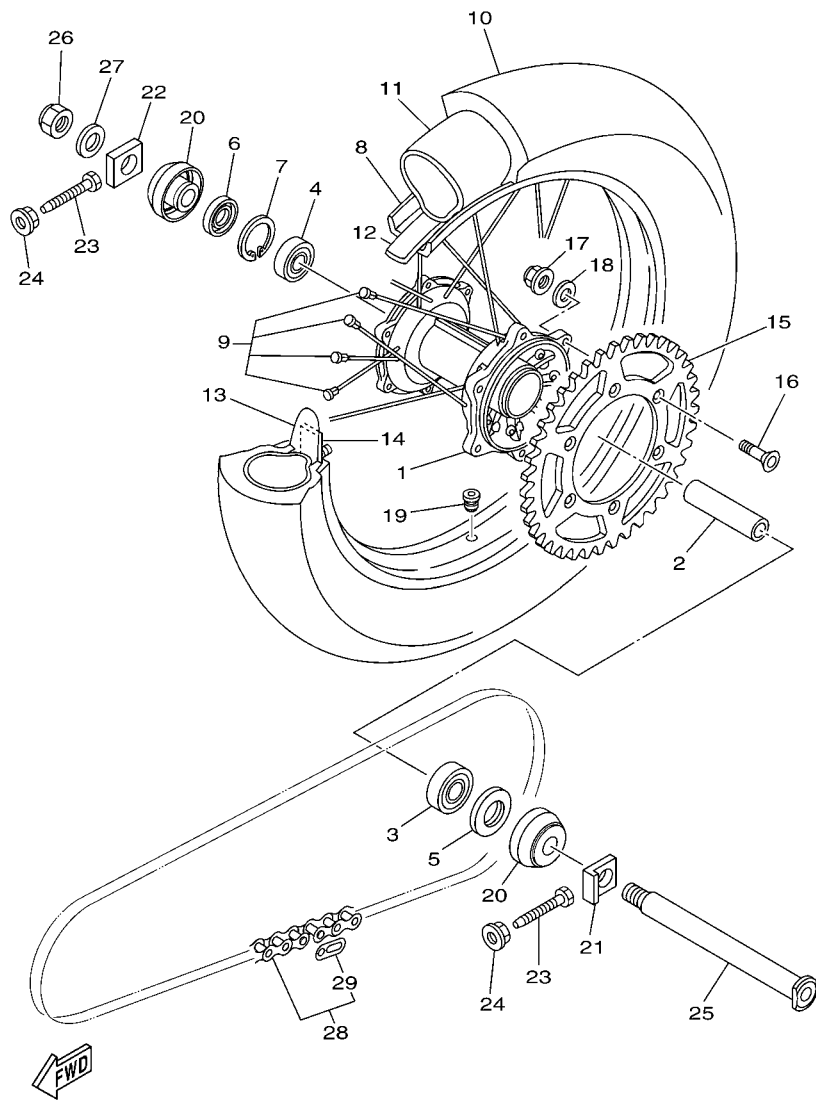

FIG. 27 REAR WHEEL

REF. NO.	PART NO.	DESCRIPTION	1SR9	1SRA	1SRB	1SRC	REMARKS
1	5ET-25311-00	HUB, REAR	1	1	1	1	
2	5ET-25317-00	SPACER, BEARING	1	1	1	1	
3	93306-27212	BEARING	1	1	1	1	
4	93306-07202	BEARING	1	1	1	1	
5	93106-30001	OIL SEAL	1	1	1	1	
6	93106-30045	OIL SEAL	1	1	1	1	
7	99009-45500	CIRCLIP	1	1	1	1	
8	94418-19003	RIM (1.85-19)	1	1	1	1	
9	5HD-25304-00	SPOKE SET, REAR	1	1	1	1	
10	94110-1913B	TIRE (100/90-19 57M D755)	1	1			DUNLOP
	94110-19009	TIRE (100/90-19 51M M602)			1		BRIDGESTONE
	94110-19020	TIRE (100/90-19 57M D756G)				1	DUNLOP
11	94210-19224	TUBE (100/90-19 M/C TR4 BTL)	1	1		1	DUNLOP
	94210-19222	TUBE (100/90-19 M/C TR4)				1	BRIDGESTONE
12	94321-19135	BAND, RIM (22-19)	1	1		1	DUNLOP
	94316-19156	BAND, RIM (1.85-19)				1	BRIDGESTONE
13	4XM-25394-00	SPACER, BEAD	1	1	1	1	
14	4XM-25364-00	DAMPER	1	1	1	1	
15	1C3-25448-00	SPROCKET, DRIVEN (48T)	1	1	1	1	STD
	1C3-25447-00	SPROCKET, DRIVEN (47T)	1	1	1	1	AP
	1C3-25449-00	SPROCKET, DRIVEN (49T)	1	1	1	1	AP
	1C3-25450-00	SPROCKET, DRIVEN (50T)	1	1	1	1	AP
	1C3-25451-00	SPROCKET, DRIVEN (51T)	1	1	1	1	AP
	1C3-25452-00	SPROCKET, DRIVEN (52T)	1	1	1	1	AP
16	90109-08078	BOLT	6	6	6	6	
17	90185-08008	NUT, SELF-LOCKING	6	6	6	6	
18	90201-08048	WASHER, PLATE	6	6	6	6	



1C35100-E270

FIG. 27 REAR WHEEL

REF. NO.	PART NO.	DESCRIPTION	1SR9	1SFA	1SRB	1SRC	REMARKS
19	90480-08608	GROMMET	1	1	1	1	
20	5TJ-2530S-80	COLLAR ASSY	2	2	2	2	
21	1C3-25388-H0	PULLER, CHAIN 1	1	1	1	1	
22	1C3-25389-H0	PULLER, CHAIN 2	1	1	1	1	
23	90101-08006	BOLT	2	2	2	2	
24	90179-08019	NUT	2	2	2	2	
25	1C3-25381-90	AXLE, WHEEL	1	1	1	1	
26	90185-20002	NUT, SELF-LOCKING	1	1	1	1	
27	90201-20020	WASHER, PLATE	1	1	1	1	
28	9Y582-28111	CHAIN (DID520DMA2-112LL)	1	1	1	1	
29	94682-28001	.JOINT, CHAIN(DID520DM G&B-RJ)	1	1	1	1	

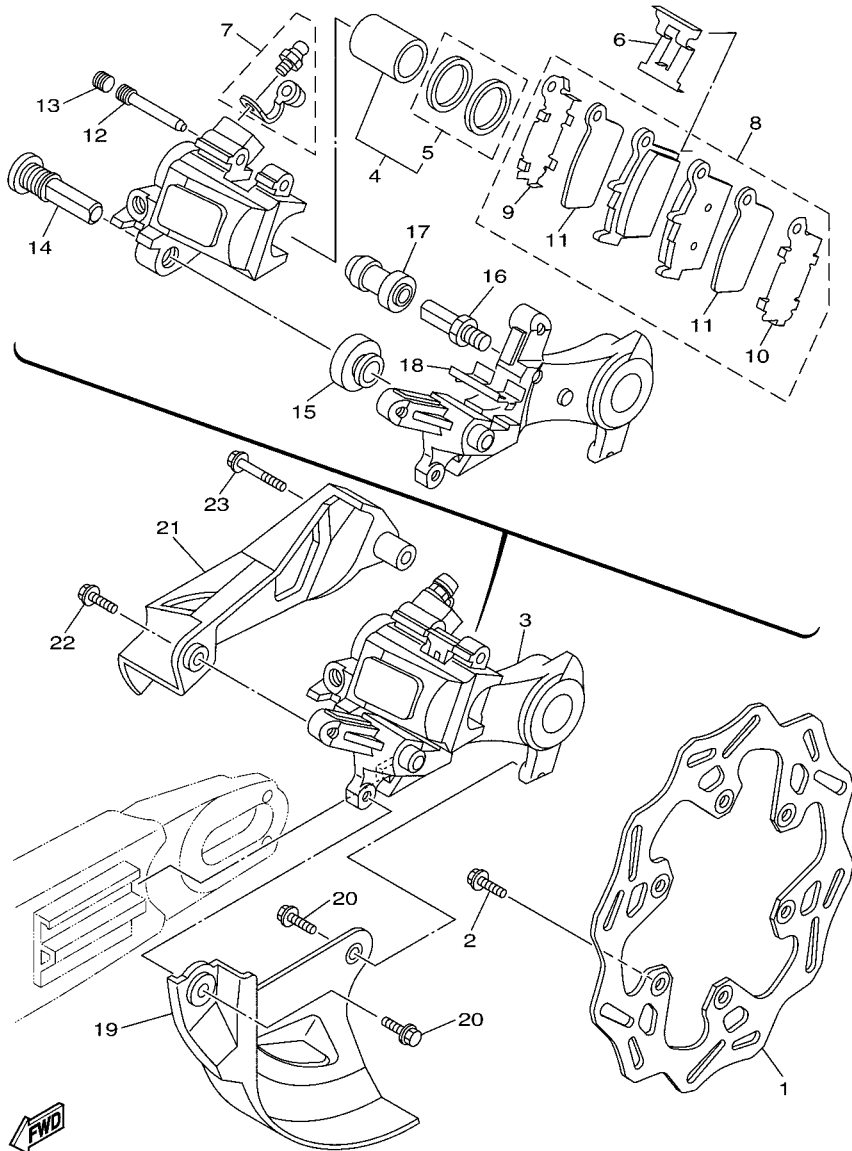

1DX5200-M320

FIG. 28 REAR BRAKE CALIPER

REF. NO.	PART NO.	DESCRIPTION	1SR9	1SFA	1SRB	1SRC	REMARKS
1	2S2-2582W-70	DISK, REAR BRAKE 2	1	1	1	1	
2	90105-06108	BOLT, FLANGE	6	6	6	6	
3	1C3-2580W-52	CALIPER ASSY, REAR 2	1	1	1	1	
4	5UN-W0057-50	.PISTON ASSY, CALIPER	1	1	1	1	
5	5UN-W0047-50	..CALIPER SEAL KIT	1	1	1	1	
6	5DH-25919-50	..SUPPORT, PAD	1	1	1	1	
7	1UY-W0048-50	.BLEED SCREW KIT	1	1	1	1	
8	1C3-W0046-50	.BRAKE PAD KIT 2	1	1	1	1	
9	5UN-25828-60	..SHIM, CALIPER	1	1	1	1	
10	5UN-25827-60	..SHIM, CALIPER	1	1	1	1	
11	5UN-22898-60	..INSULATOR, HEAT	2	2	2	2	
12	8CR-25924-00	.PIN, PAD	1	1	1	1	
13	5DH-25916-00	.PLUG	1	1	1	1	
14	5DH-25914-50	.PIN, SLIDE	1	1	1	1	
15	3JD-25917-00	.BOOT, CALIPER	1	1	1	1	
16	5UN-25914-00	.PIN, SLIDE	1	1	1	1	
17	1UY-25937-51	.BOOT 2	1	1	1	1	
18	5UN-25913-00	.RETAINER	1	1	1	1	
19	1C3-25718-50	PROTECTOR, DISK BRAKE	1	1	1	1	
20	90105-06110	BOLT, FLANGE	2	2	2	2	
21	1C3-27491-50	PROTECTOR	1	1	1	1	
22	90105-06107	BOLT, FLANGE	1	1	1	1	
23	90105-06111	BOLT, FLANGE	1	1	1	1	

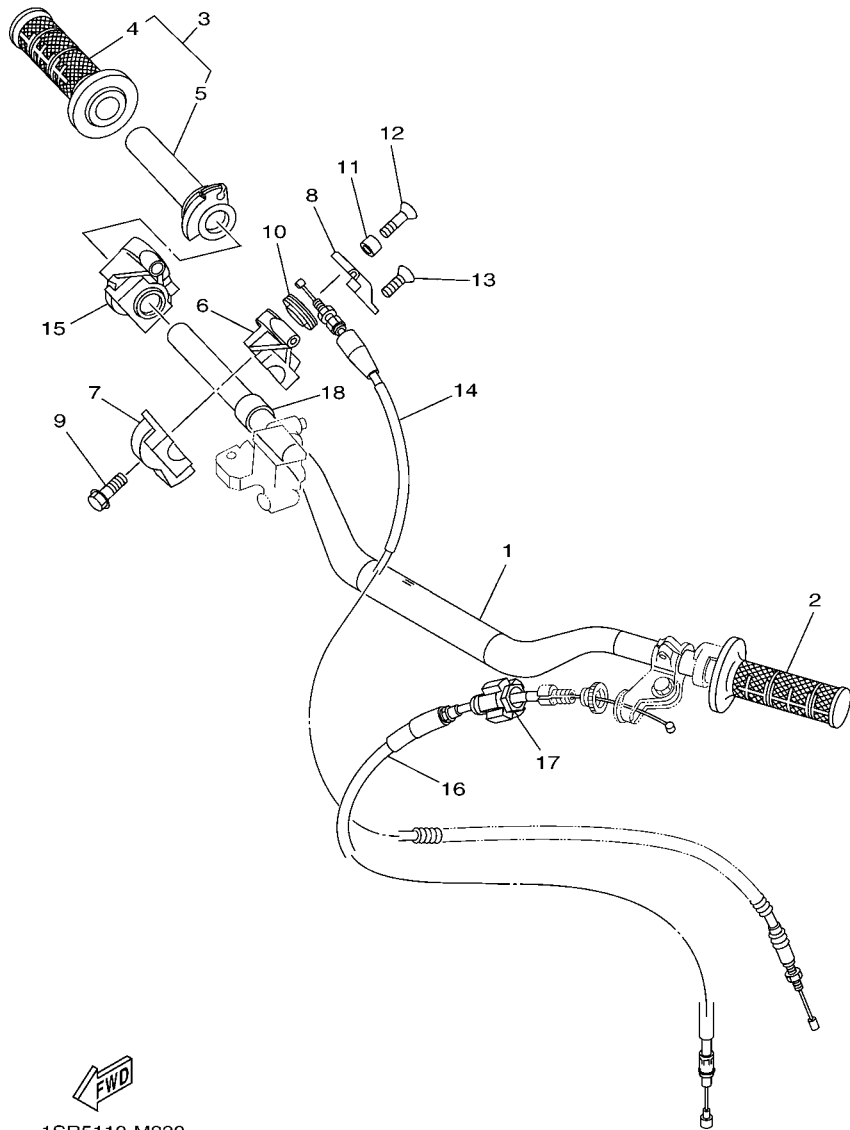

FIG. 29 STEERING HANDLE & CABLE

REF. NO.	PART NO.	DESCRIPTION	1SR9	1SFA	1SRB	1SRC	REMARKS
1	17D-26111-H0	HANDLEBAR	1	1	1	1	
2	4GY-26241-00	GRIP	1	1	1	1	
3	4XM-26240-00	GRIP ASSY	1	1	1	1	
4	4GY-26242-00	.GRIP (RIGHT)	1	1	1	1	
5	4XM-26243-00	.TUBE, THROTTLE GUIDE	1	1	1	1	
6	1C3-26281-90	CAP, GRIP UPPER	1	1	1	1	
7	1C3-26282-90	CAP, GRIP UNDER	1	1	1	1	
8	1C3-2628H-90	CAP, WIRE	1	1	1	1	
9	90105-06112	BOLT, FLANGE	2	2	2	2	
10	1C3-26273-90	ROTOR	1	1	1	1	
11	90387-04003	COLLAR	1	1	1	1	
12	98680-04510	SCREW, OVAL HEAD	1	1	1	1	
13	98680-04516	SCREW, OVAL HEAD	1	1	1	1	
14	1C3-26311-90	CABLE, THROTTLE 1	1	1	1	1	
15	4SS-26287-01	COVER, CAP GRIP	1	1	1	1	
16	1C3-26335-90	CABLE, CLUTCH	1	1	1	1	
17	1C3-26342-50	BOOT, CABLE	1	1	1	1	
18	90387-227H7	COLLAR	1	1	1	1	

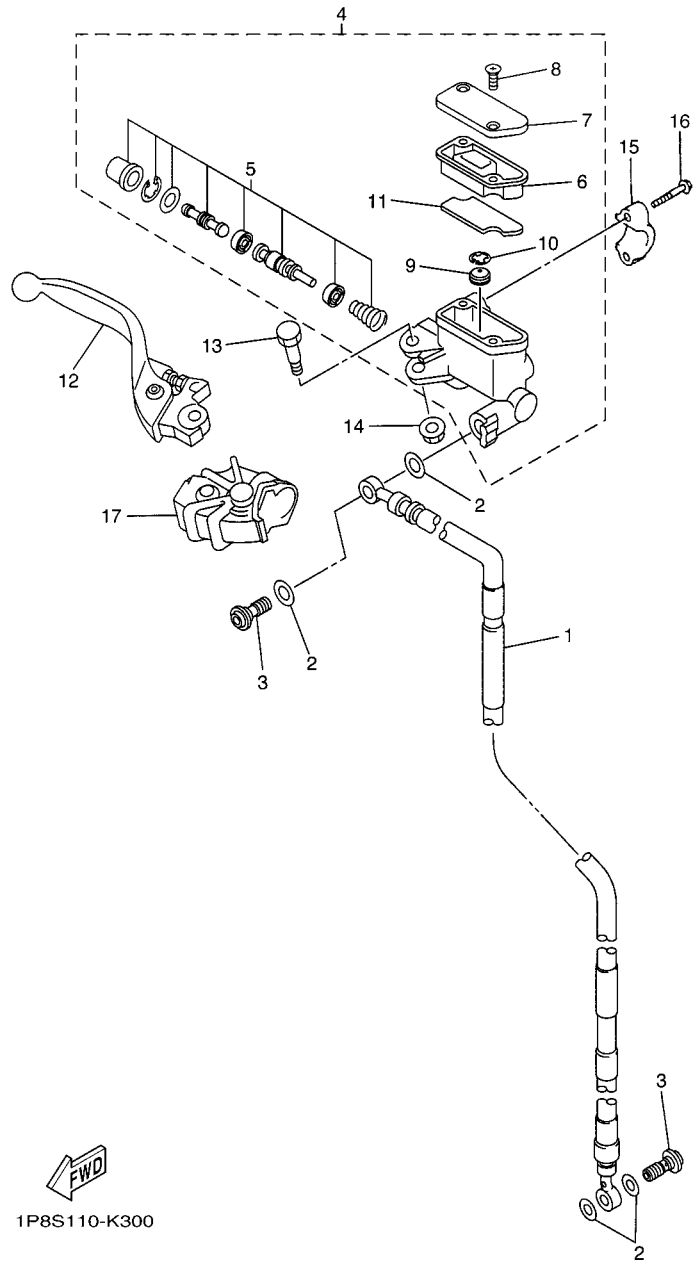
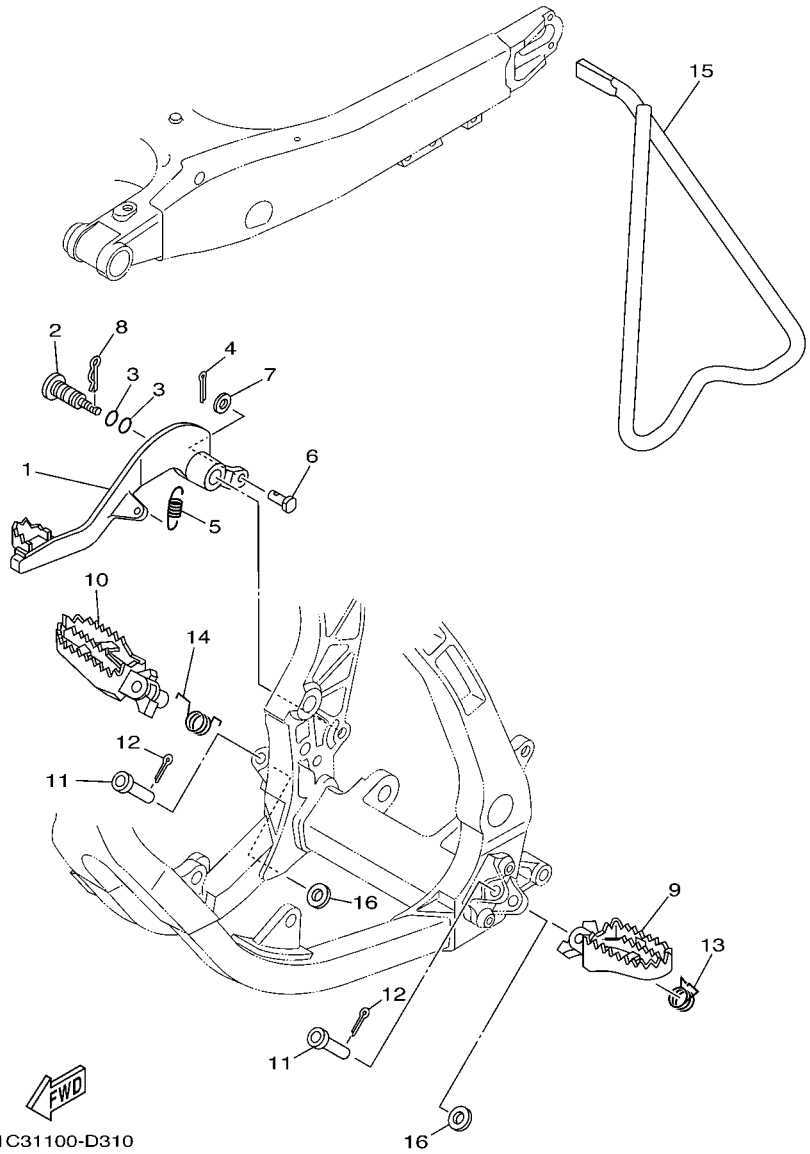

FIG. 30 FRONT MASTER CYLINDER

REF. NO.	PART NO.	DESCRIPTION	1SR9	1SFA	1SRB	1SRC	REMARKS
1	5XC-25872-L0	HOSE, BRAKE 1	1	1	1	1	
2	90430-10005	GASKET	4	4	4	4	
3	90401-10172	BOLT, UNION	2	2	2	2	
4	5XC-W2587-00	MASTER CYLINDER SUB ASSY	1	1	1	1	
5	5XC-W0041-00	.CYLINDER KIT, MASTER	1	1	1	1	
6	5XC-25854-G0	.DIAPHRAGM, RESERVOIR	1	1	1	1	
7	5XC-25852-G0	.CAP, RESERVOIR	1	1	1	1	
8	98706-04012	.SCREW, FLAT HEAD	2	2	2	2	
9	5CG-25715-00	.SEPARATOR ASSY	1	1	1	1	
10	5CG-2585G-00	.CIRCLIP	1	1	1	1	
11	5XC-25853-G0	.FLOAT, RESERVOIR	1	1	1	1	
12	5XC-83922-L0	LEVER 2	1	1	1	1	
13	5MV-2589F-00	BOLT, LEVER	1	1	1	1	
14	95701-06500	NUT, WITH WASHER	1	1	1	1	
15	5MV-25867-00	BRACKET, MASTER CYLINDER	1	1	1	1	
16	5MV-25833-00	BOLT, FITTING	2	2	2	2	
17	5XC-26372-G0	COVER, HANDLE LEVER 1	1	1	1	1	



1C31100-D310

FIG. 31 STAND & FOOTREST

REF. NO.	PART NO.	DESCRIPTION	1SR9	1SFA	1SRB	1SRC	REMARKS
1	4XM-27200-21	PEDAL, BRAKE	1	1	1	1	
2	1C3-27217-10	BOLT	1	1	1	1	
3	93210-11073	O-RING	2	2	2	2	
4	91402-20012	PIN, COTTER	1	1	1	1	
5	90506-16007	SPRING, TENSION	1	1	1	1	
6	90240-08120	PIN, CLEVIS	1	1	1	1	
7	90201-08044	WASHER, PLATE	1	1	1	1	
8	90468-16001	CLIP	1	1	1	1	
9	5XE-27411-02	FOOTREST 1	1	1	1	1	
10	5XE-27421-02	FOOTREST 2	1	1	1	1	
11	90240-10004	PIN, CLEVIS	2	2	2	2	
12	91402-25015	PIN, COTTER	2	2	2	2	
13	90508-28015	SPRING, TORSION	1	1	1	1	
14	90508-28018	SPRING, TORSION	1	1	1	1	
15	1C3-27311-00	STAND, SIDE	1	1	1	1	
16	90201-10032	WASHER, PLATE	2	2	2	2	

FIG. 32 REAR MASTER CYLINDER

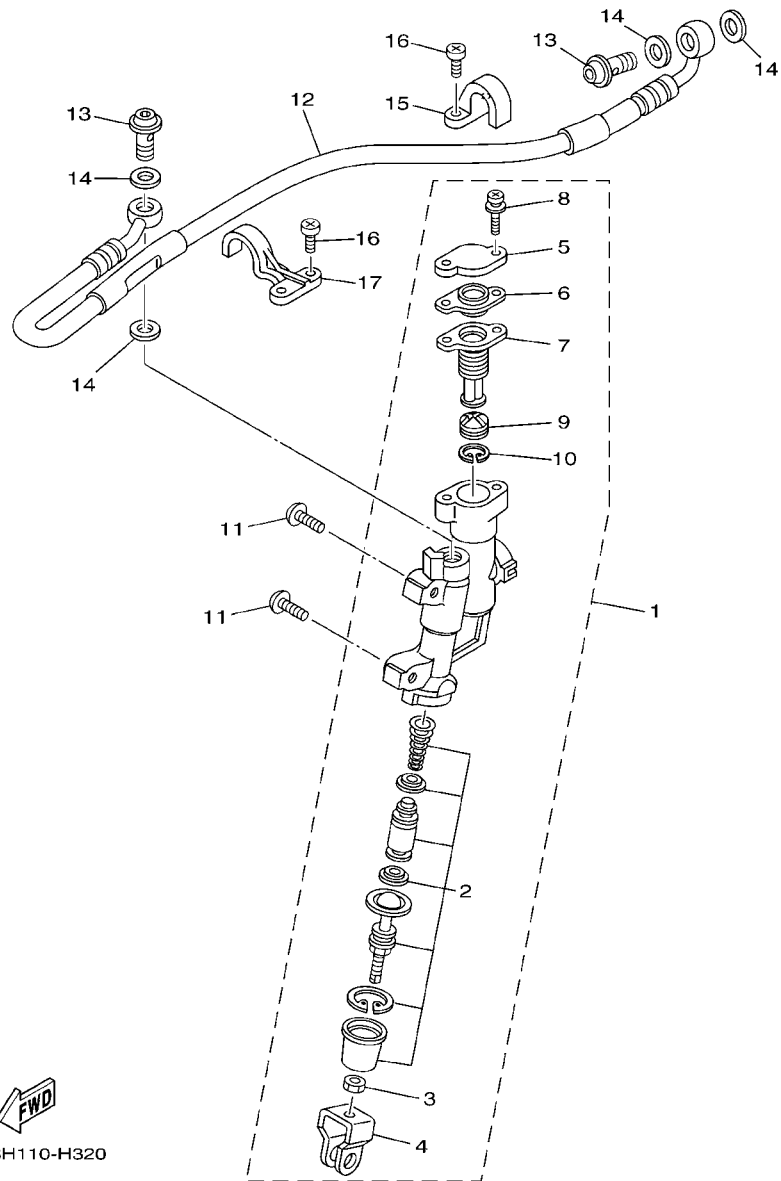

FWD
1C3H110-H320

REF. NO.	PART NO.	DESCRIPTION	1SR9	1SRA	1SRB	1SRC	REMARKS
1	17D-2583V-00	RR. MASTER CYLINDER ASSY.	1	1	1	1	
2	5UN-W0042-50	.CYLINDER KIT, MASTER	1	1	1	1	
3	5UN-27218-00	.NUT	1	1	1	1	
4	5UN-27222-00	.JOINT	1	1	1	1	
5	5UN-25852-50	.CAP, RESERVOIR	1	1	1	1	
6	5UN-2585B-00	.PLATE, DIAPHRAGM	1	1	1	1	
7	5UN-25854-00	.DIAPHRAGM, RESERVOIR	1	1	1	1	
8	5UN-27217-00	.BOLT	2	2	2	2	
9	5CG-25715-00	.SEPARATOR ASSY	1	1	1	1	
10	5CG-2585G-00	.CIRCLIP	1	1	1	1	
11	90111-06059	BOLT,HEX. SOCKET BUTTON	2	2	2	2	
12	5XC-25873-L0	HOSE, BRAKE 2	1	1	1	1	
13	90401-10172	BOLT, UNION	2	2	2	2	
14	90430-10005	GASKET	4	4	4	4	
15	1C3-25886-50	HOLDER, BRAKE HOSE	1	1	1	1	
16	98502-05010	SCREW, PAN HEAD	4	4	4	4	
17	1C3-25876-50	HOLDER, BRAKE HOSE 2	1	1	1	1	

FIG. 33 GENERATOR

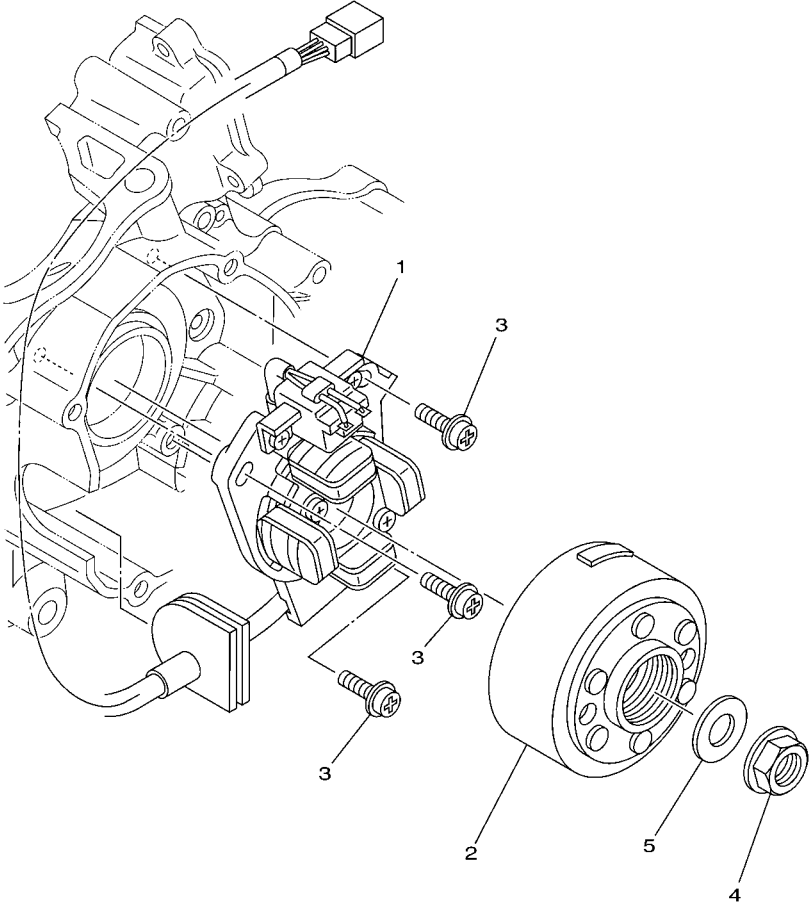

REF. NO.	PART NO.	DESCRIPTION	1SR9	1SFA	1SRB	1SRC	REMARKS
1	1C3-85560-10	BASE ASSY	1	1	1	1	
2	1C3-85550-01	ROTOR ASSY	1	1	1	1	
3	90149-06108	SCREW	3	3	3	3	
4	90179-12004	NUT	1	1	1	1	
5	90201-127E1	WASHER, PLATE	1	1	1	1	

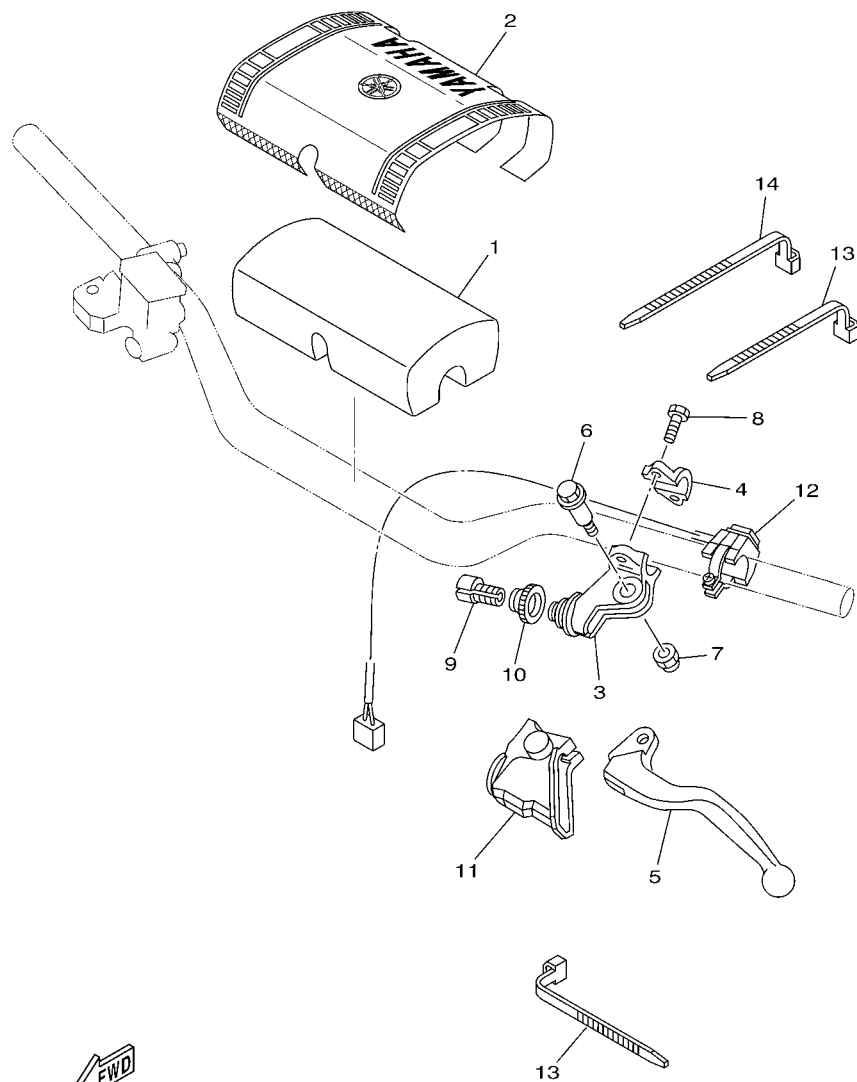

 1C31100-D330



 1SR5110-M340

FIG. 34 HANDLE SWITCH & LEVER

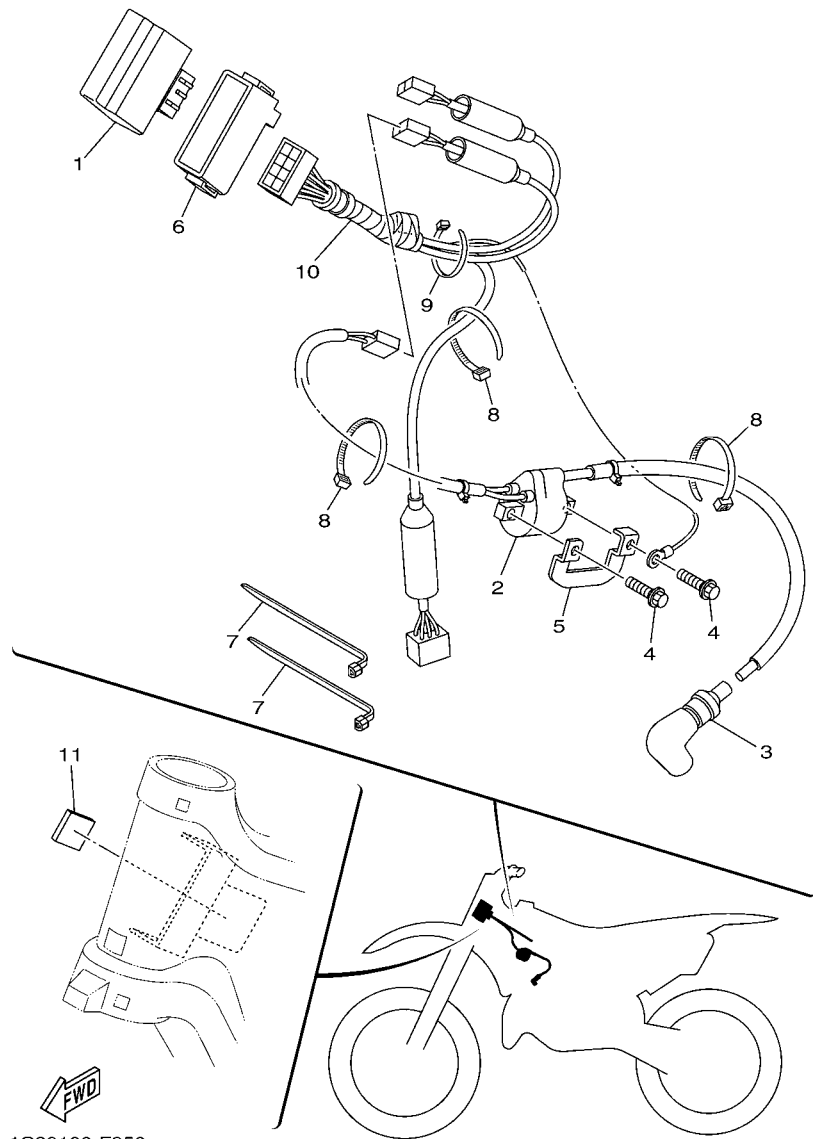
REF. NO.	PART NO.	DESCRIPTION	1SR9	1SFA	1SRB	1SRC	REMARKS
1	5XC-26124-90	PROTECTOR, HANDLEBAR	1	1	1	1	
2	17D-26143-H0	COVER, HANDLE UPPER 1	1	1	1	1	
3	5XE-82911-00	HOLDER, LEVER 1	1	1	1	1	
4	5TG-82913-00	HOLDER, LEVER LOWER 1	1	1	1	1	
5	5MV-83912-00	LEVER 1	1	1	1	1	
6	90109-06034	BOLT	1	1	1	1	
7	5LP-84126-10	NUT, LENS FITTING	1	1	1	1	
8	90101-05033	BOLT	2	2	2	2	
9	5HD-26337-00	BOLT, ADJUSTING	1	1	1	1	
10	5HD-83951-00	BOLT, CABLE ADJUSTING	1	1	1	1	
11	5HD-26372-00	COVER, HANDLE LEVER 1	1	1	1	1	
12	1C3-83976-00	SWITCH, HANDLE 1	1	1	1	1	
13	90464-13077	CLAMP	2	2	2	2	
14	90464-13073	CLAMP	1	1	1	1	



1C39100-F350

FIG. 35 ELECTRICAL 1

REF. NO.	PART NO.	DESCRIPTION	1SR9	1SRA	1SRB	1SRC	REMARKS
1	1C3-85540-10	C.D.I. UNIT ASSY	1				
	1SR-85540-00	C.D.I. UNIT ASSY		1	1	1	
2	1C3-82320-00	IGNITION COIL ASSY	1	1	1	1	
3	8DG-82370-00	.PLUG CAP ASSY	1	1	1	1	
4	90105-06060	BOLT, FLANGE	2	2	2	2	
5	1C3-8231U-10	CORE, SIDE	1	1	1	1	
6	1C3-85546-00	BAND	1	1	1	1	
7	90464-15195	CLAMP	2	2	2	2	
8	90465-13275	CLAMP	3	3	3	3	
9	5Y9-12491-00	CLAMP 1	1	1	1	1	
10	1C3-82509-10	WIRE, SUB LEAD	1	1	1	1	
11	1C3-2139X-00	DAMPER	1	1	1	1	

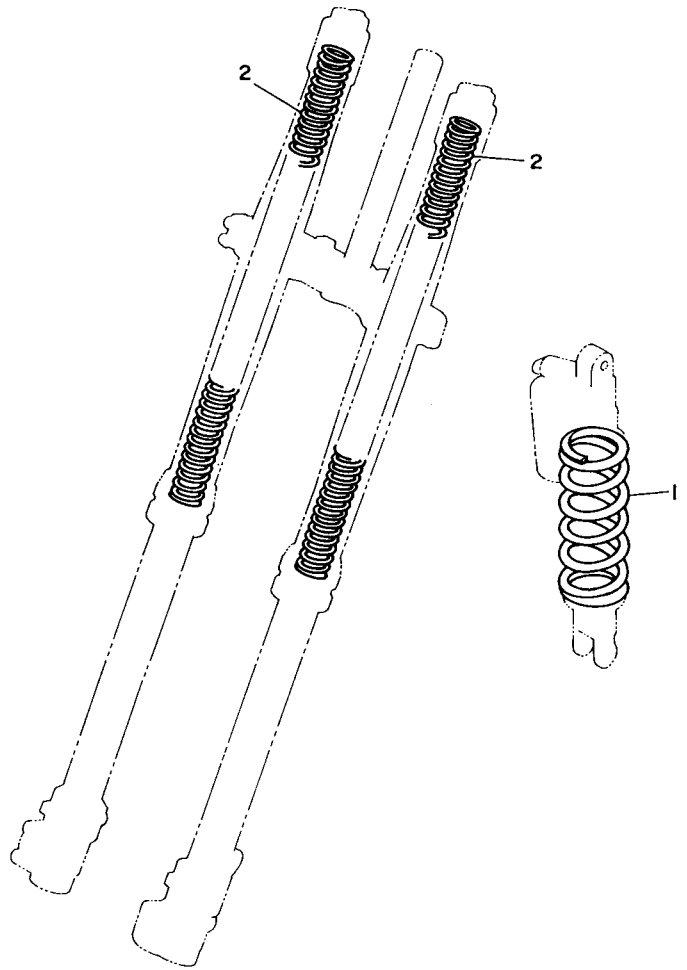

3JD1010-9360

FIG. 36 ALTERNATE FOR CHASSIS

REF. NO.	PART NO.	DESCRIPTION	1SR9	1SFA	1SRB	1SRC	REMARKS
1	5UN-22212-00	SPRING (K=42N/MM)	1	1	1	1	AP
	5UN-22212-10	SPRING (K=44N/MM)	1	1	1	1	AP
	5UN-22212-30	SPRING (K=48N/MM)	1	1	1	1	AP
	5UN-22212-40	SPRING (K=50N/MM)	1	1	1	1	AP
	5UN-22212-50	SPRING (K=52N/MM)	1	1	1	1	AP
	5UN-22212-60	SPRING (K=54N/MM)	1	1	1	1	AP
	5UN-22212-70	SPRING (K=56N/MM)	1	1	1	1	AP
	5UN-22212-A0	SPRING (K=APPROX.44N/MM)	1	1	1	1	AP
	5UN-22212-B0	SPRING (K=APPROX.46N/MM)	1	1	1	1	AP
	5UN-22212-C0	SPRING (K=APPROX.48N/MM)	1	1	1	1	AP
	5UN-22212-D0	SPRING (K=APPROX.50N/MM)	1	1	1	1	AP
	5UN-22212-E0	SPRING (K=APPROX.52N/MM)	1	1	1	1	AP
	5UN-22212-F0	SPRING (K=APPROX.54N/MM)	1	1	1	1	AP
	5UN-22212-G0	SPRING (K=APPROX.56N/MM)	1	1	1	1	AP
2	1C3-23141-A1	SPRING, FRONT FORK(K=3.9N/MM)	2	2	2	2	AP
	1C3-23141-B1	SPRING, FRONT FORK(K=4.0N/MM)	2	2	2	2	AP
	1C3-23141-C1	SPRING, FRONT FORK(K=4.1N/MM)	2	2	2	2	AP
	1C3-23141-D1	SPRING, FRONT FORK(K=4.2N/MM)	2	2	2	2	AP
	1C3-23141-E1	SPRING, FRONT FORK(K=4.3N/MM)	2	2	2	2	AP
	1C3-23141-F1	SPRING, FRONT FORK(K=4.4N/MM)	2	2	2	2	AP
	1C3-23141-G1	SPRING, FRONT FORK(K=4.5N/MM)	2	2	2	2	AP
	1C3-23141-H1	SPRING, FRONT FORK(K=4.6N/MM)	2	2	2	2	AP
	1C3-23141-J1	SPRING, FRONT FORK(K=4.7N/MM)	2	2	2	2	AP

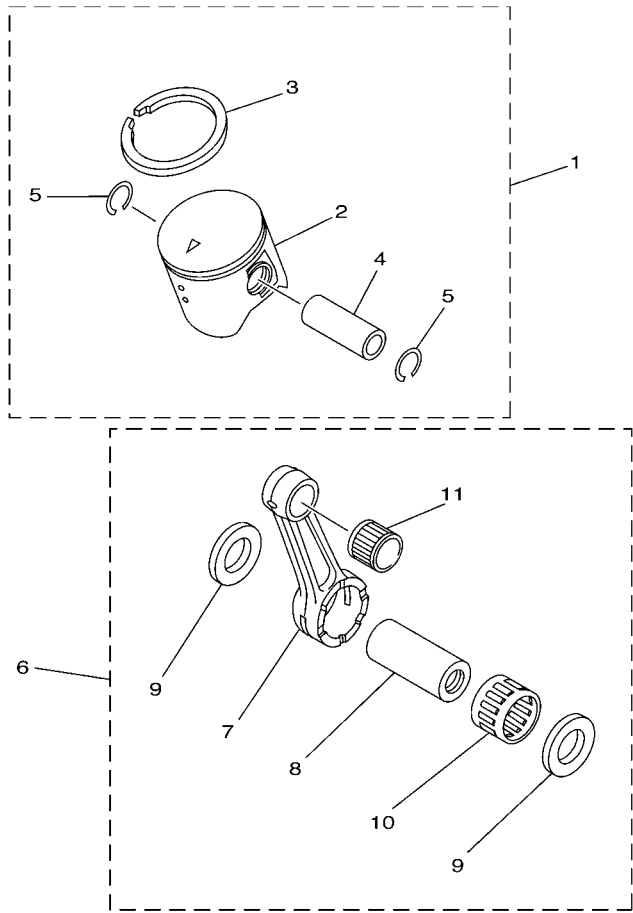

5NY1100-A370

FIG. 37 OPTIONAL PARTS 1

REF. NO.	PART NO.	DESCRIPTION	1SR9	1SFA	1SRB	1SRC	REMARKS
1	1C3-11630-00	PISTON ASSY (STD)	1	1	1	1	
2	1C3-11631-00-B0	.PISTON (STD)	1	1	1	1	ORANGE
3	5NY-11611-00	.RING, PISTON	1	1	1	1	
4	1C3-11633-00	.PIN, PISTON	1	1	1	1	
5	93450-16068	.CIRCLIP	2	2	2	2	
6	1C3-11650-00	CONNECTING ROD ASSY	1	1	1	1	
7	1C3-11651-00	.ROD, CONNECTING	1	1	1	1	
8	3JD-11681-10	.PIN, CRANK 1	1	1	1	1	
9	90209-22326	.WASHER	2	2	2	2	
10	93310-52238	.BEARING	1	1	1	1	
11	93310-21510	.BEARING	1	1	1	1	

NUMERICAL INDEX

PART NO.	REF. NO.	PART NO.	REF. NO.	PART NO.	REF. NO.	PART NO.	REF. NO.	PART NO.	REF. NO.	PART NO.	REF. NO.
1C3-11111-10	1 - 1	1C3-12465-00	5 - 7	4KM-14142-50	7 - 21	3Y1-15363-10	10 - 11	1C3-18185-00	15 - 1	5UN-22176-00	20 - 15
4JY-11166-00	1 - 23	1C3-12481-00	5 - 8	137-14143-80	7 - 22	4JT-15381-01	13 - 2	1C3-18511-00	14 - 8	30X-22178-00	16 - 12
1C3-11311-20	1 - 7	1C3-12482-00	5 - 9	137-14143-82	7 - 22		13 - 26	1C3-18512-00	14 - 9	3JD-22178-20	16 - 17
1C3-1131D-00	1 - 14	1C3-12483-00	5 - 10	137-14143-84	7 - 22	1C3-15411-10	10 - 1	1C3-18513-00	14 - 10	1C3-2217A-00	19 - 20
4SS-1131M-01	1 - 22	1C3-12484-00	5 - 11	137-14143-86	7 - 22	1C3-15415-10	10 - 16	3XV-18531-00	14 - 11	1C3-2217F-50	19 - 26
5HD-1131V-00	1 - 17	5Y9-12491-00	35 - 9	137-14143-88	7 - 22	1C3-15421-10	10 - 5	4JG-18531-00	14 - 12	4V4-22184-00	16 - 13
1C3-1132D-00	1 - 15	353-13115-01	9 - 3	137-14143-90	7 - 22	1C3-15431-00	10 - 8	1C3-18541-00	14 - 1	5MV-22184-00	20 - 16
1C3-11351-00	1 - 8	1C3-13565-00	6 - 7	137-14143-92	7 - 22	1C3-15451-00	10 - 2	1C3-18562-00	14 - 4	2S2-22199-70	19 - 12
1C3-11354-00	1 - 25	1C3-13610-20	6 - 1	137-14143-94	7 - 22	1C3-15462-00	10 - 9	1C3-21101-50	16 - 1	1SR-22200-10	20 - 1
5UN-11395-00	1 - 20	5UN-13613-00	6 - 2	51R-14146-00	7 - 26	1C3-15463-00	10 - 17	5PA-2118K-00	17 - 18	1SR-22200-20	20 - 1
1C3-11400-20	3 - 1	5MV-13616-10	6 - 3	5MV-14146-00	7 - 32	4DB-15620-10	11 - 11	5PA-2118K-10	17 - 19	1SR-22200-30	20 - 1
1C3-11410-10	3 - 2	1C3-13625-10	6 - 6	2K6-14147-00	7 - 18	4DB-15621-03	11 - 12	5PA-2118K-20	17 - 18	1C3-22201-H0	20 - 2
1C3-11420-20	3 - 3	1C3-14101-41	7 - 1	5ET-14147-00	7 - 25	1C3-15641-00	11 - 5	1C3-21190-90	16 - 8	1C3-22201-J0	20 - 2
5NY-11611-00	3 - 9	1C3-14101-51	7 - 1	3MA-14159-00	7 - 4	1C3-15651-00	11 - 1	1C3-21244-10	16 - 33	1C3-22201-K0	20 - 2
	37 - 3	4PE-14103-00	7 - 14	5ET-1416A-00	7 - 24	1C3-15660-00	11 - 4	1C3-21336-00	16 - 2	5UN-22212-00	36 - 1
1C3-11630-00	37 - 1	5UN-14104-00	7 - 6	3JE-14171-00	7 - 5	1C3-15666-00	11 - 9	1C3-2135F-00	19 - 34	5UN-22212-10	36 - 1
1C3-11631-00-B0	37 - 2	4PE-14107-38	7 - 11	5NY-14181-00	7 - 35	1C3-16111-00	12 - 1	1C3-2139R-00	19 - 35	5UN-22212-20	20 - 9
1C3-11631-02-A0	3 - 8	1C3-14112-40	7 - 23	5ET-14185-00	7 - 17	1C3-16150-00	12 - 4	1C3-2139X-00	35 - 11	5UN-22212-30	36 - 1
1C3-11631-02-B0	3 - 8	1C3-14112-42	7 - 23	353-14186-00	7 - 10	1C3-16181-00	12 - 12	1C3-21425-00	16 - 26	5UN-22212-40	36 - 1
1C3-11631-02-C0	3 - 8	5ET-14115-00	7 - 19	4PE-14194-00	7 - 3	3XJ-16321-00	12 - 7	1C3-21447-10	16 - 3	5UN-22212-50	36 - 1
1C3-11631-02-D0	3 - 8	284-14116-H2	7 - 20	5MV-14194-00	7 - 30	3XJ-16324-01	12 - 6	1C3-21448-10	16 - 4	5UN-22212-60	36 - 1
1C3-11633-00	3 - 10	284-14116-H3	7 - 20	10V-14196-00	7 - 16	5HD-16351-00	12 - 8	1C3-21511-51	17 - 1	5UN-22212-70	36 - 1
	37 - 4	284-14116-H4	7 - 20	2HH-14197-00	7 - 28	5NL-16356-00	12 - 17	4XL-2153A-10	22 - 57	5UN-22212-A0	36 - 1
1C3-11650-00	37 - 6	284-14116-H5	7 - 20	5ET-14197-00	7 - 15	1C3-16357-10	12 - 22		22 - 59	5UN-22212-B0	36 - 1
1C3-11651-00	3 - 4	284-14116-H6	7 - 20	5MV-14216-00	7 - 33	5NY-16371-00	12 - 5	4ES-2153E-20	17 - 17	5UN-22212-C0	36 - 1
	37 - 7	284-14116-J2	7 - 20	5HD-14261-00	7 - 2	1C3-16380-00	12 - 23	5XE-21610-20	17 - 7	5UN-22212-D0	36 - 1
3JD-11681-10	3 - 5	284-14116-J3	7 - 20	5MV-14261-00	7 - 34	1C3-17121-10	13 - 11	5XE-21635-10	17 - 8	5UN-22212-E0	36 - 1
	37 - 8	284-14116-J4	7 - 20	5ET-14261-01	7 - 8	1C3-17131-10	13 - 8	5TA-21642-00	17 - 13	5UN-22212-F0	36 - 1
4SS-11832-00	1 - 18	284-14116-J5	7 - 20	5NY-14401-01	6 - 11	1C3-17151-10	13 - 10	3RV-21668-A0	19 - 36	5UN-22212-G0	36 - 1
5CU-11911-00	2 - 19	284-14116-J6	7 - 20	5NY-14417-00	6 - 16	1C3-17161-10	13 - 5	3RV-21668-B0	19 - 37	1C3-22213-L0	20 - 7
5CU-11912-00	2 - 18	284-14116-K2	7 - 20	5NY-14442-00	6 - 15	1C3-17211-10	13 - 15	5NY-21711-00	18 - 1	1C3-22214-50	20 - 10
4JY-11915-10	2 - 1	284-14116-K3	7 - 20	4XM-14451-00	6 - 19	1C3-17221-10	13 - 24	5GJ-21717-00	16 - 9	5MV-22224-00	20 - 11
5X4-11921-02	2 - 11	284-14116-K4	7 - 20	1C3-14453-10	6 - 12	1C3-17231-20	13 - 20	1C3-21721-50	18 - 4	4JX-22226-00	20 - 4
3JE-11922-01	2 - 8	284-14116-K5	7 - 20	5NY-14455-20	6 - 14	1C3-17241-10	13 - 19	5NL-2172A-20	18 - 19	3SP-22234-00	20 - 6
5CU-11952-00	2 - 14	284-14116-K6	7 - 20	3JD-14458-01	6 - 22	1C3-17251-10	13 - 21	5XE-21730-00	18 - 9	5NY-22241-00	20 - 22
5NY-11953-00	2 - 12	4PE-14131-00	7 - 13	5NY-14459-00	6 - 13	1C3-17261-10	13 - 16	1SR-2173E-20	18 - 12	5XE-22242-00	20 - 19
1C3-11990-10	2 - 3	87M-14137-00	7 - 29	1FN-14565-00	7 - 7	1C3-17411-10	13 - 4	1SR-2173F-20	18 - 16	1C3-22253-50	20 - 12
1C3-11992-00	1 - 29	22F-14139-00	7 - 36	1C3-14610-00	8 - 1	1C3-17421-00	13 - 14	5XE-21740-00	18 - 13	1C3-22253-L1	20 - 17
1C3-11993-00	1 - 30	4KM-14142-30	7 - 21	4JY-14615-00	8 - 16	1C3-17466-00	10 - 6	5BE-21749-00	18 - 3	4AA-22259-40	20 - 8
1C3-11995-00	1 - 33	4KM-14142-32	7 - 21	5MV-14642-00	8 - 2	1C3-18101-00	15 - 2		18 - 6	4AA-22259-50	20 - 8
1C3-1240A-00	5 - 1	4KM-14142-35	7 - 21	1C3-1469A-00	8 - 19	1C3-18110-10	15 - 9	5TA-21749-00	18 - 11	4AA-22259-60	20 - 8
1C3-12422-00	4 - 10	4KM-14142-37	7 - 21	1C3-14753-00	8 - 17	5LP-18122-01	15 - 3		18 - 15	1C3-22355-00	19 - 3
1C3-12428-00	4 - 13	4KM-14142-40	7 - 21	1C3-14763-00	8 - 6	1C3-18140-10	14 - 5	1C3-22110-90	19 - 1	4EW-22474-00	20 - 14
1C3-12450-00	4 - 1		7 - 21	565-14771-00	8 - 4	1C3-18172-00	15 - 17	1C3-22121-00	19 - 30	3JE-22475-00	20 - 13
1C3-12453-10	4 - 2	4KM-14142-42	7 - 21	5CU-14771-01	8 - 9	3XJ-18173-10	15 - 12	1C3-22122-00	19 - 31	5NY-22475-00	20 - 18
1C3-12461-00	5 - 5	4KM-14142-45	7 - 21	1C3-15111-01	9 - 1	3XJ-18178-00	15 - 13	2S2-22128-70	19 - 13	5UN-22898-60	28 - 11
22W-12462-00	5 - 6		7 - 21	4V4-15118-00	9 - 13	3XJ-18182-00	15 - 14	1C3-22141-10	19 - 17	1C3-22969-90	19 - 11
1C3-12465-00	5 - 2	4KM-14142-47	7 - 21	1C3-15121-00	9 - 2	3XJ-18184-00	15 - 16	2S2-22151-70	19 - 10	1C3-23102-D0	22 - 1

NUMERICAL INDEX

PART NO.	REF. NO.	PART NO.	REF. NO.	PART NO.	REF. NO.	PART NO.	REF. NO.	PART NO.	REF. NO.	PART NO.	REF. NO.
1C3-23102-E0	22 - 1	5XC-23170-P0	22 - 10	1C3-24770-H1	24 - 1	5MV-2589F-00	30 - 13	1C3-82509-10	35 - 10	90105-08132	16 - 11
1C3-23103-D0	22 - 25		22 - 34	5NY-25104-00	25 - 6	5UN-25913-00	28 - 18	5XE-82911-00	34 - 3	90105-08133	16 - 20
1C3-23103-E0	22 - 25	5XE-23171-L0	22 - 4	5NY-25111-00	25 - 1	5UN-25914-00	28 - 16	5TG-82913-00	34 - 4	90105-08134	21 - 12
5XC-23110-N0	22 - 27		22 - 28	5NY-25117-00	25 - 3	5DH-25914-50	28 - 14	5MV-83912-00	34 - 5		22 - 51
5XC-23111-00	22 - 21	5DH-23183-00	20 - 5	5XC-25181-G0	25 - 11	3SP-25914-51	26 - 12	5XC-83922-L0	30 - 12	90105-08137	26 - 16
	22 - 45	509-23184-L0	20 - 3	5XC-25183-G0	25 - 12	5DH-25916-00	26 - 10	5HD-83951-00	34 - 10	90105-08154	22 - 52
276-23114-00	22 - 23	1C3-23188-L0	22 - 13	5XC-25186-G0	25 - 13		28 - 13	1C3-83976-00	34 - 12	90105-10175	16 - 23
	22 - 47		22 - 37	5HD-25304-00	27 - 9	3JD-25917-00	26 - 13	5LP-84126-10	34 - 7	90105-10176	16 - 30
5XC-23120-N0	22 - 3	1C3-23188-N0	22 - 14	5TJ-2530S-80	27 - 20		28 - 15	1SR-85540-00	35 - 1	90109-06034	34 - 6
5XE-23125-L0	22 - 5		22 - 38	5ET-25311-00	27 - 1	5DH-25919-00	26 - 6	1C3-85540-10	35 - 1	90109-06193	14 - 7
	22 - 29	1C3-23188-P0	22 - 15	5ET-25317-00	27 - 2	5DH-25919-50	28 - 6	1C3-85546-00	35 - 6	90109-06232	22 - 60
1C3-23136-P0	22 - 2		22 - 39	4XM-25364-00	27 - 14	8CR-25924-00	28 - 12	1C3-85550-01	33 - 2	90109-06245	6 - 24
	22 - 26	1C3-23188-R0	22 - 16	1C3-25381-90	27 - 25	3SP-25926-51	26 - 11	1C3-85560-10	33 - 1	90109-08078	27 - 16
1C3-23141-A1	36 - 2		22 - 40	1C3-25388-H0	27 - 21	5DH-25933-00	26 - 9	5XC-W0041-00	30 - 5	90111-06059	32 - 11
1C3-23141-B1	36 - 2	1C3-23190-L0	22 - 18	1C3-25389-H0	27 - 22	1UY-25937-51	26 - 14	5UN-W0042-50	32 - 2	90111-08028	16 - 27
1C3-23141-C1	36 - 2		22 - 42	4XM-25394-00	27 - 13		28 - 17	5XC-W0045-00	26 - 8	90116-08027	1 - 2
1C3-23141-D1	36 - 2	1C3-23340-M0	22 - 49	5SF-25394-00	25 - 10	17D-26111-H0	29 - 1	1C3-W0046-50	28 - 8	90116-08028	1 - 10
1C3-23141-E1	36 - 2	5XE-23389-00	22 - 53	1C3-25447-00	27 - 15	5XC-26124-90	34 - 1	5KM-W0047-10	26 - 5	90116-08031	1 - 9
1C3-23141-F1	36 - 2	4EW-23416-00	21 - 2	1C3-25448-00	27 - 15	17D-26143-H0	34 - 2	5UN-W0047-50	28 - 5	90119-06147	17 - 3
1C3-23141-G1	36 - 2	1C3-23435-50	21 - 5	1C3-25449-00	27 - 15	4XM-26240-00	29 - 3	1UY-W0048-50	26 - 7	90119-06149	17 - 14
1C3-23141-H1	36 - 2	5XC-23441-90	21 - 8	1C3-25450-00	27 - 15	4GY-26241-00	29 - 2		28 - 7	90119-06151	21 - 14
1C3-23141-J1	36 - 2	5XC-23442-90	21 - 9	1C3-25451-00	27 - 15	4GY-26242-00	29 - 4	5XC-W0057-00	26 - 4	90119-08095	18 - 8
1C3-23141-P0	22 - 20	17D-23466-00	22 - 61	1C3-25452-00	27 - 15	4XM-26243-00	29 - 5	5UN-W0057-50	28 - 4	90122-06005	6 - 21
	22 - 44	17D-23467-00	22 - 62	5CG-25715-00	30 - 9	1C3-26273-90	29 - 10	5XC-W2587-00	30 - 4	90149-06074	13 - 3
1C3-23142-L0	22 - 19	1C3-23485-61	21 - 13		32 - 9	1C3-26281-90	29 - 6	90101-05033	34 - 8		13 - 27
	22 - 43	1C3-24110-90	23 - 1	1C3-25718-50	28 - 19	1C3-26282-90	29 - 7	90101-06041	15 - 18	90149-06108	23 - 23
5XE-23144-L0	22 - 9	4EW-2412F-00	23 - 13	5XC-2580T-G0	26 - 3	4SS-26287-01	29 - 15	90101-08006	27 - 23		33 - 3
	22 - 33	5XE-24144-00	23 - 6	1C3-2580W-52	28 - 3	1C3-2628H-90	29 - 8	90105-06060	35 - 4	90149-10031	16 - 5
1C3-23145-M0	22 - 7	3XJ-2415E-A1	17 - 4	5XC-2581T-G0	26 - 1	1C3-26311-90	29 - 14	90105-06064	18 - 17	90151-04003	19 - 2
	22 - 31	3XJ-2415E-B1	17 - 5	5UN-25827-60	28 - 10	1C3-26335-90	29 - 16	90105-06081	14 - 3	90151-06045	11 - 16
5XC-23146-00	22 - 6	3XJ-2415E-C1	17 - 4	5UN-25828-60	28 - 9	5HD-26337-00	34 - 9	90105-06085	9 - 14	90151-06051	26 - 2
	22 - 30	4SR-2416E-00	17 - 6	2S2-2582W-70	28 - 1	1C3-26342-50	29 - 17	90105-06099	17 - 9	90159-06016	12 - 10
1AE-23147-00	22 - 17	3SP-24173-00	23 - 12	5MV-25833-00	30 - 16	5HD-26372-00	34 - 11	90105-06101	17 - 11	90159-06021	18 - 18
	22 - 41	5XE-24176-10	23 - 9	17D-2583V-00	32 - 1	5XC-26372-G0	30 - 17	90105-06103	18 - 7	90170-16326	12 - 16
1C3-23147-L0	22 - 11	1C3-24181-00	23 - 15	5XC-25849-G0	26 - 15	4XM-27200-21	31 - 1	90105-06104	19 - 14	90170-24003	21 - 6
	22 - 35	1C3-24182-00	23 - 24	5UN-25852-50	32 - 5	5UN-27217-00	32 - 8	90105-06105	19 - 16	90176-08005	1 - 3
5XC-2314F-00	22 - 24	1C3-24183-00	23 - 27	5XC-25852-G0	30 - 7	1C3-27217-10	31 - 2	90105-06107	22 - 54	90179-06028	19 - 15
	22 - 48	1C3-24184-00	23 - 28	5XC-25853-G0	30 - 11	5UN-27218-00	32 - 3		23 - 8	90179-08019	1 - 12
5XE-23153-L0	22 - 8	5NY-24186-00	23 - 10	5UN-25854-00	32 - 7	5UN-27222-00	32 - 4		28 - 22		27 - 24
	22 - 32	1SR-24240-20	23 - 26	5XC-25854-G0	30 - 6	1C3-27311-00	31 - 15	90105-06108	28 - 2	90179-08674	16 - 28
2HH-23158-L0	22 - 22	3XJ-24380-00	23 - 4	5UN-2585B-00	32 - 6	5XE-27411-02	31 - 9	90105-06110	28 - 20	90179-10658	16 - 24
	22 - 46	3JD-24500-20	23 - 16	5CG-2585G-00	30 - 10	5XE-27421-02	31 - 10	90105-06111	5 - 17		16 - 31
5XC-2315H-00	22 - 58	4X8-24512-10	23 - 17		32 - 10	1C3-27491-50	28 - 21		28 - 23	90179-12004	33 - 4
5XC-2315J-00	22 - 56	5MV-24514-00	7 - 31	5MV-25867-00	30 - 15	5ET-28166-10	16 - 34	90105-06112	29 - 9	90179-16011	25 - 14
1C3-2316A-T0	22 - 12	3AJ-24534-10	23 - 18	5XC-25872-L0	30 - 1	5PG-2816R-00	17 - 18	90105-06118	5 - 19	90179-18001	13 - 32
	22 - 36	5NY-24610-10	23 - 2	5XC-25873-L0	32 - 12	1C3-8231U-10	35 - 5	90105-06178	22 - 63	90179-28013	21 - 3
1C3-2316A-U0	22 - 12	1C3-2470F-H0	24 - 2	1C3-25876-50	32 - 17	1C3-82320-00	35 - 2	90105-08071	12 - 3	90183-06023	6 - 23
	22 - 36	5NY-24728-10	24 - 3	1C3-25886-50	32 - 15	8DG-82370-00	35 - 3	90105-08085	16 - 10	90185-08008	27 - 17

NUMERICAL INDEX

PART NO.	REF. NO.	PART NO.	REF. NO.	PART NO.	REF. NO.	PART NO.	REF. NO.	PART NO.	REF. NO.	PART NO.	REF. NO.
90185-08009	16 - 21	90215-20003	13 - 31	90464-13073	34 - 14	92902-10200	20 - 21	93332-00068	21 - 1	95022-06025	10 - 19
90185-10012	20 - 23	90240-08120	31 - 6	90464-13077	34 - 13	92904-05600	16 - 7	93332-00081	22 - 50	95022-06030	8 - 20
90185-14010	19 - 33	90240-10004	31 - 11	90464-15195	35 - 7	93102-08004	4 - 7	93340-21008	12 - 18		10 - 13
90185-16002	19 - 18	90267-32070	6 - 17	90465-13275	23 - 25	93102-08307	4 - 8	93340-21505	2 - 17	95022-06040	10 - 14
90185-20002	27 - 26	90280-03045	3 - 16		35 - 8	93102-10008	12 - 25	93342-22217	19 - 5	95022-06050	10 - 15
90201-03313	6 - 18	90387-04003	29 - 11	90467-090A2	5 - 4	93102-12224	15 - 11	93410-22039	13 - 7	95022-06065	4 - 15
90201-05021	2 - 5	90387-06009	17 - 15	90467-100A1	23 - 21	93102-17263	11 - 10		13 - 17		10 - 18
90201-06032	17 - 10		18 - 2	90467-13062	1 - 24	93102-20485	3 - 14	93410-26067	13 - 22	95022-08040	16 - 16
90201-06033	8 - 14		18 - 5	90468-16001	31 - 8	93102-22419	3 - 15	93440-07182	4 - 6	95022-10016	9 - 6
	17 - 12		18 - 10	90468-26048	11 - 6	93102-26468	25 - 4		12 - 20	95602-10200	20 - 20
90201-06060	11 - 18		18 - 14	90480-08608	27 - 19	93102-28012	13 - 28	93450-16068	3 - 11	95602-12200	21 - 11
90201-06077	8 - 7	90387-06039	8 - 24	90480-15528	5 - 15	93104-08040	1 - 21		37 - 5	95701-06500	30 - 14
90201-06078	8 - 13	90387-06065	5 - 16	90480-16404	8 - 25		2 - 7	93507-16020	2 - 20	97002-05012	2 - 6
90201-06086	8 - 21	90387-06090	17 - 2	90480-16561	8 - 10	93104-12003	15 - 7	93507-32009	11 - 14	97002-05016	1 - 31
90201-06571	5 - 18	90387-06104	22 - 55	90480-17004	8 - 23	93106-22002	19 - 6	93511-32027	12 - 21	97002-06012	24 - 4
90201-08043	16 - 22	90387-06121	8 - 22	90480-18549	23 - 7	93106-30001	27 - 5	93603-12007	4 - 3	97004-05012	16 - 6
90201-08044	31 - 7	90387-063G3	8 - 11	90501-052G5	15 - 15	93106-30045	27 - 6	93603-14240	2 - 21	97022-06012	11 - 17
90201-08045	16 - 14	90387-08032	4 - 5	90501-12081	11 - 13	93109-21001	19 - 28	93604-10011	4 - 14	97702-60016	17 - 16
90201-08048	27 - 18	90387-08041	16 - 15	90501-23598	12 - 9	93109-25001	19 - 22		10 - 20	98502-03006	6 - 4
90201-08055	16 - 29	90387-085E1	2 - 4	90501-300A0	2 - 13	93109-28043	19 - 7	93608-33002	15 - 8	98502-03008	23 - 19
90201-080H1	12 - 19	90387-086N4	16 - 19	90506-16007	31 - 5	93210-11073	31 - 3	9383B-13218	13 - 30	98502-05010	32 - 16
90201-080L8	1 - 4	90387-08785	1 - 28	90506-20018	8 - 3	93210-15171	11 - 15	94108-21012	25 - 7	98502-05012	2 - 2
90201-08512	4 - 4	90387-107T9	2 - 22	90508-16134	1 - 27	93210-16314	9 - 16	94108-21025	25 - 7	98502-05014	7 - 27
90201-10032	31 - 16	90387-14016	19 - 29	90508-261B7	14 - 6	93210-19123	10 - 12	94108-2112Y	25 - 7	98502-06030	10 - 7
90201-12020	15 - 6	90387-152F2	2 - 16	90508-26450	11 - 7	93210-63442	1 - 5	94110-19009	27 - 10	98507-04008	7 - 9
90201-12028	21 - 10	90387-16025	19 - 23	90508-28015	31 - 13	93210-90785	1 - 6	94110-19020	27 - 10	98507-04014	7 - 12
90201-127E1	33 - 5	90387-172K2	12 - 2	90508-28018	31 - 14	93300-60801	2 - 10	94110-1913B	27 - 10	98680-04510	29 - 12
90201-14020	19 - 32	90387-18010	19 - 8	90508-29020	15 - 4		4 - 9	94209-21229	25 - 8	98680-04516	29 - 13
90201-150U6	2 - 15	90387-18012	19 - 9	90560-12280	15 - 5	93300-60814	4 - 9	94210-19222	27 - 11	98702-06025	23 - 14
90201-16018	19 - 19	90387-22004	13 - 29	91312-04006	2 - 9	93300-60839	16 - 18	94210-19224	27 - 11	98706-04012	30 - 8
90201-171G4	11 - 8	90387-227H7	29 - 18	91312-04010	1 - 19	93306-00326	13 - 13	94227-21101	25 - 8	98902-05016	1 - 26
90201-175F6	11 - 2	90401-10172	30 - 3	91312-05012	1 - 16	93306-00442	13 - 1	94309-21161	25 - 9	98902-06025	23 - 11
90201-20020	27 - 27		32 - 13	91312-06045	9 - 8	93306-07202	27 - 4	94316-19156	27 - 12	99009-17400	11 - 3
90201-20611	12 - 11	90430-06014	4 - 11	91312-06055	9 - 9	93306-20351	13 - 12	94321-19135	27 - 12	99009-45500	27 - 7
	12 - 14		10 - 22	91312-06065	9 - 10	93306-20447	13 - 25	94330-21084	25 - 9	99530-08016	10 - 10
90201-21014	19 - 25	90430-10005	30 - 2	91312-06075	9 - 11	93306-27212	27 - 3	94416-21005	25 - 5	99530-10116	9 - 5
90201-22555	13 - 6		32 - 14	91402-20012	31 - 4	93306-37204	3 - 13	94418-19003	27 - 8	99590-10114	1 - 11
90201-24016	21 - 7	90430-10188	9 - 7	91402-25015	31 - 12	93306-90408	14 - 2	94682-28001	27 - 29	99590-17016	9 - 15
90201-286K9	21 - 4	90445-08605	9 - 4	91A20-05065	5 - 3	93306-90409	25 - 2	94702-00193	1 - 13	9Y582-28111	27 - 28
90202-05193	23 - 22	90445-09003	23 - 3	92012-06010	8 - 18	93310-21510	3 - 12	94709-00193	1 - 13		
90209-06096	6 - 20	90445-09005	23 - 5	92012-06012	10 - 21		37 - 11	95022-06010	4 - 12		
90209-16011	19 - 24	90445-111J0	23 - 20	92502-06030	10 - 3	93310-22539	12 - 13	95022-06012	8 - 5		
90209-18135	13 - 9	90450-22001	5 - 13	92902-03100	6 - 5	93310-52238	3 - 7	95022-06014	8 - 12		
90209-20008	13 - 18	90450-25001	5 - 14	92902-05600	1 - 32		37 - 10	95022-06020	6 - 8		
90209-22326	3 - 6	90450-28001	5 - 12	92902-06100	24 - 5	93315-11040	12 - 24		15 - 10		
	37 - 9	90450-54007	6 - 9	92902-06600	10 - 4	93315-32166	19 - 21	95022-06025	4 - 16		
90209-23012	13 - 23	90450-70002	6 - 10	92902-10200	16 - 25		19 - 27		8 - 8		
90215-16289	12 - 15	90461-10136	9 - 12		16 - 32	93317-22262	19 - 4		8 - 15		