



PARTS CATALOGUE

TT-R110EB (5B6J) U.S.A.



1L5B6-110E1

()

TT-R110EB
PARTS CATALOGUE
©2011 by Yamaha Motor Co., Ltd.
1st edition, August 2011
All rights reserved.
Any reprinting or unauthorized use
without the written permission of
Yamaha Motor Co., Ltd.
is expressly prohibited.
Printed in Japan.

FOREWORD

This Parts Catalogue is related to the parts for the model(s) on the cover page. When you are ordering replacement parts, please refer to this Parts Catalogue and quote both part numbers and part names correctly.

1. Modifications or additions which have been made after the issue of the Parts Catalogue will be announced in the Parts News.

It is advisable that you make the necessary corrections to the Parts Catalogue according to the Parts News.

2. Abbreviations

The following abbreviations are used in this Parts Catalogue.

“UR” Use specified parts number.

“UN” Use as many as needed.

“AP” Alternate Parts

“LM” Locally Made (Parts need to be ordered locally)

“F#” Frame No. (Applicable machine No.)

“O/S” Over Size

3. The number of components for assembly

- Parts, which are to be supplied in an assembly, are listed with a dot (.) in front of the part name as shown below.
- The numeral appearing to the right of each component part indicates the quantity of parts for each assembly unit.

PART NO.	DESCRIPTION	Q'TY	REMARKS
2F5-83310-60	FRONT FLASHER LIGHT ASSY	2	
115-83311-60	.BULB (6V-18W)	1	

4. Applicable colours of graphics are represented in the “REMARKS” as shown below.

PART NO.	DESCRIPTION	Q'TY	REMARKS
2N4-24110-00-X5	FUEL TANK COMP.	2	MXR
3J1-24240-10	.GRAPHIC, FUEL TANK	1	FOR MXR

5. Note that the illustrations for reference in finding parts numbers are not to be used for assembling. When assembling, please use the applicable service manual.

6. The asterisk (*) before a reference number indicates modified items after the first edition.

CONTENTS

ENGINE

CYLINDER HEAD	1
CRANKSHAFT & PISTON	2
VALVE	3
CAMSHAFT & CHAIN	4
OIL PUMP	5
INTAKE	6
CARBURETOR	7
EXHAUST	9
CRANKCASE	10
CRANKCASE COVER 1	11
STARTER	12
STARTER CLUTCH	13
CLUTCH	14
TRANSMISSION	16
SHIFT CAM & FORK	17
SHIFT SHAFT	18

CHASSIS

FRAME	19
FENDER	20
SIDE COVER	21
REAR ARM & SUSPENSION	22
STEERING	23
FRONT FORK	24
FUEL TANK	26
SEAT	28
FRONT WHEEL	29
REAR WHEEL	30
STEERING HANDLE & CABLE	32
STAND & FOOTREST	33
GENERATOR	34
STARTING MOTOR	35
HANDLE SWITCH & LEVER	36
ELECTRICAL 1	37

INDEX

NUMERICAL INDEX	38
-----------------------	----

FIG. 1 CYLINDER HEAD

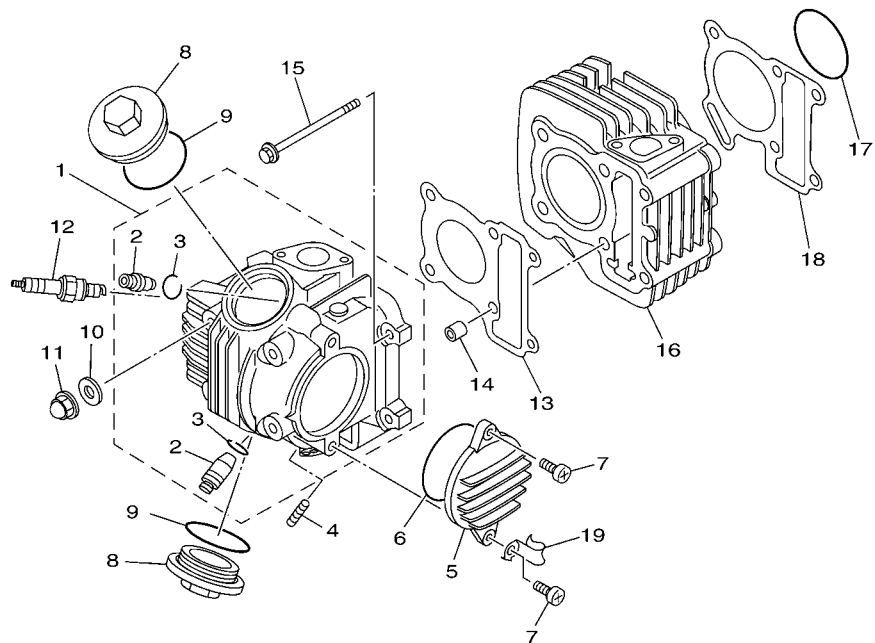

5B61100-G010

REF. NO.	PART NO.	DESCRIPTION	5B6J				REMARKS
1	5TP-E1111-30	HEAD, CYLINDER 1	1				
2	4ST-11134-11	.GUIDE, VALVE 2	2				
3	93440-10153	.CIRCLIP	2				
4	90116-06804	BOLT, STUD	2				
5	4ST-E1185-00	COVER, CYLINDER HEAD SIDE 3	1				
6	93210-638G6	O-RING	1				
7	98507-06016	SCREW, PAN HEAD	2				
8	4ST-E1186-00	COVER, CYLINDER HEAD SIDE 2	2				
9	93210-448G4	O-RING	2				
10	90201-08609	WASHER, PLATE	4				
11	90176-08026	NUT, CROWN	4				
12	94700-00880	PLUG, SPARK (NGK CR6HSA)	1				
13	3S0-E1181-00	GASKET, CYLINDER HEAD 1	1				
14	91810-14809	PIN, DOWEL	2				
15	95027-06090	BOLT, FLANGE	2				
16	5TP-E1310-01	CYLINDER	1				
17	93210-568G8	O-RING	1				
18	4ST-E1351-02	GASKET, CYLINDER	1				
19	90465-08230	CLAMP	1				

FIG. 2 CRANKSHAFT & PISTON

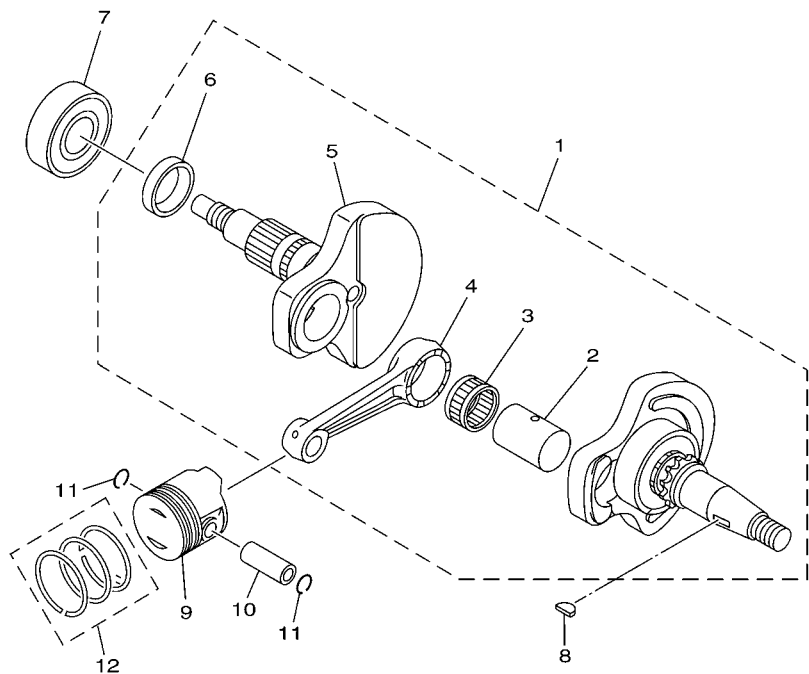

REF. NO.	PART NO.	DESCRIPTION	SB6J				REMARKS
1	5TP-WE140-20	CRANKSHAFT ASSY	1				
2	5LM-E1681-00	.PIN, CRANK 1	1				
3	93310-526Y6	.BEARING	1				
4	5TN-E1651-02	.ROD, CONNECTING	1				
5	5TP-E1422-00	.CRANK 2	1				
6	5ER-E1445-00	.SPACER	1				
7	93306-205YG	BEARING	1				
8	90280-03017	KEY, WOODRUFF	1				
9	3S0-E1631-00-A0	PISTON (STD)	1				
	3S0-E1636-00	PISTON (0.50MM O/S)	1				AP
	3S0-E1638-00	PISTON (1.00MM O/S)	1				AP
10	5LM-E1633-00	PIN, PISTON	1				
11	93450-14088	CIRCLIP	2				
12	5TP-E1603-20	PISTON RING SET (STD)	1				
	5TP-E1605-20	PISTON RING SET (0.50MM O/S)	1				AP
	5TP-E1607-20	PISTON RING SET (1.00MM O/S)	1				AP

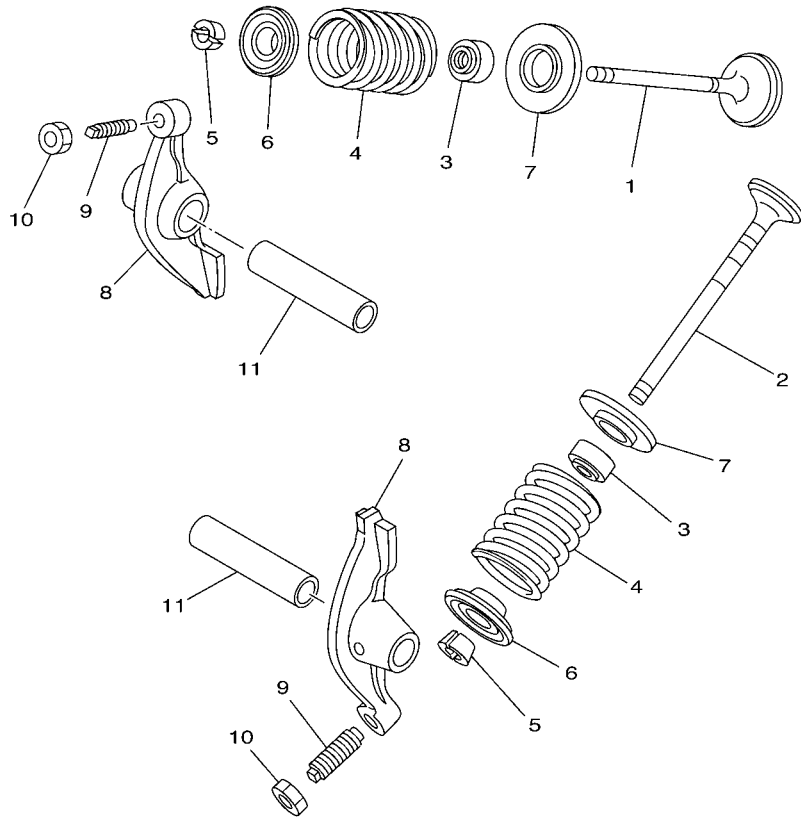

2S01422-E020



4ST1460-6030

FIG. 3 VALVE

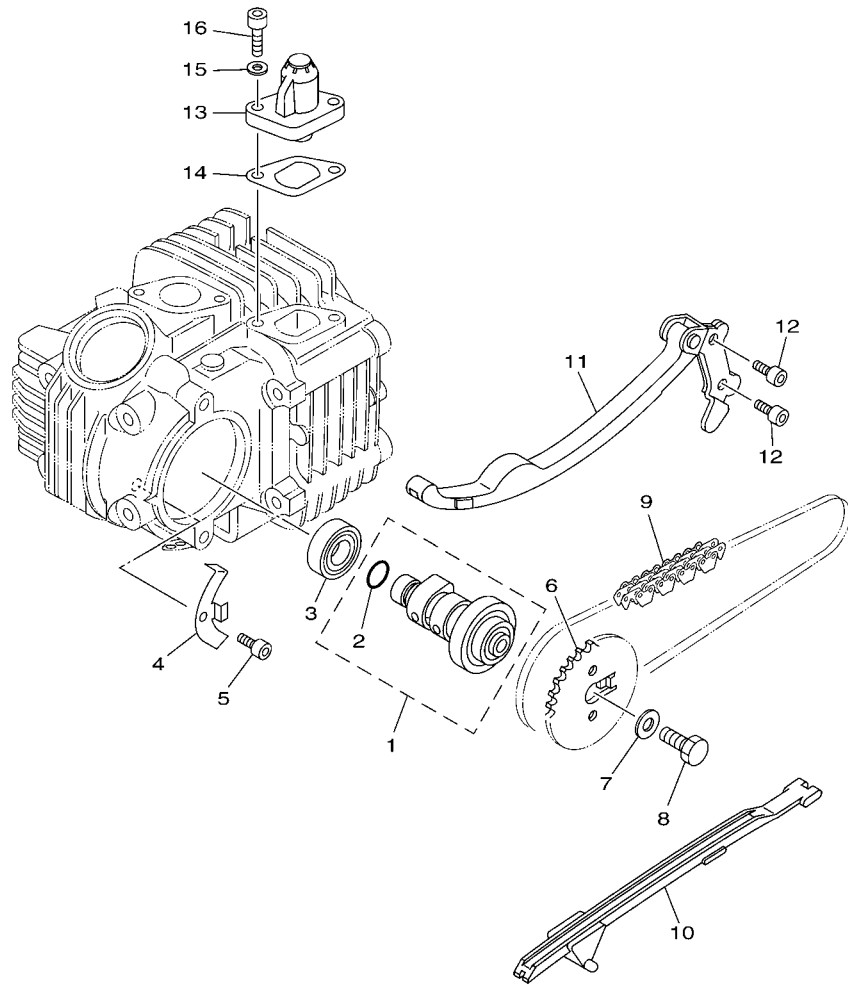
REF. NO.	PART NO.	DESCRIPTION	5B6J				REMARKS
1	5TP-E2111-00	VALVE, INTAKE	1				
2	5TP-E2121-00	VALVE, EXHAUST	1				
3	5ER-E2119-00	SEAL, VALVE STEM	2				
4	5TN-E2114-00	SPRING, VALVE OUTER	2				
5	3S0-E2118-00	COTTER, VALVE	4				
6	5TN-12117-00	RETAINER, VALVE SPRING	2				
7	5TN-E2126-00	SEAT, VALVE SPRING 2	2				
8	2P2-E2151-00	ARM, VALVE ROCKER	2				
9	5VV-E2159-10	SCREW, VALVE ADJUSTING	2				
10	2P2-E2158-00	NUT, LOCK	2				
11	4ST-E2156-00	SHAFT, ROCKER 2	2				



3S31422-E040

FIG. 4 CAMSHAFT & CHAIN

REF. NO.	PART NO.	DESCRIPTION	SB6J				REMARKS
1	5TP-E2170-00	CAMSHAFT ASSY 1	1				
2	93210-10804	.O-RING	1				
3	93306-002X2	BEARING	1				
4	5TP-E111F-00	PLATE	1				
5	91317-06012	BOLT	1				
6	5TP-E2176-00	SPROCKET, CAM CHAIN	1				
7	90201-08326	WASHER, PLATE	1				
8	90101-08590	BOLT	1				
9	94568-B3086	CHAIN	1				
10	2P2-E2231-00	GUIDE, STOPPER 1	1				
11	2P2-E2241-00	GUIDE, STOPPER 2	1				
12	91317-06016	BOLT	2				
13	2P2-E2210-00	TENSIONER ASSY, CAM CHAIN	1				
14	3S0-E2213-00	GASKET, TENSIONER CASE	1				
15	90430-06014	GASKET	2				
16	91317-06018	BOLT	2				

FIG. 5 OIL PUMP

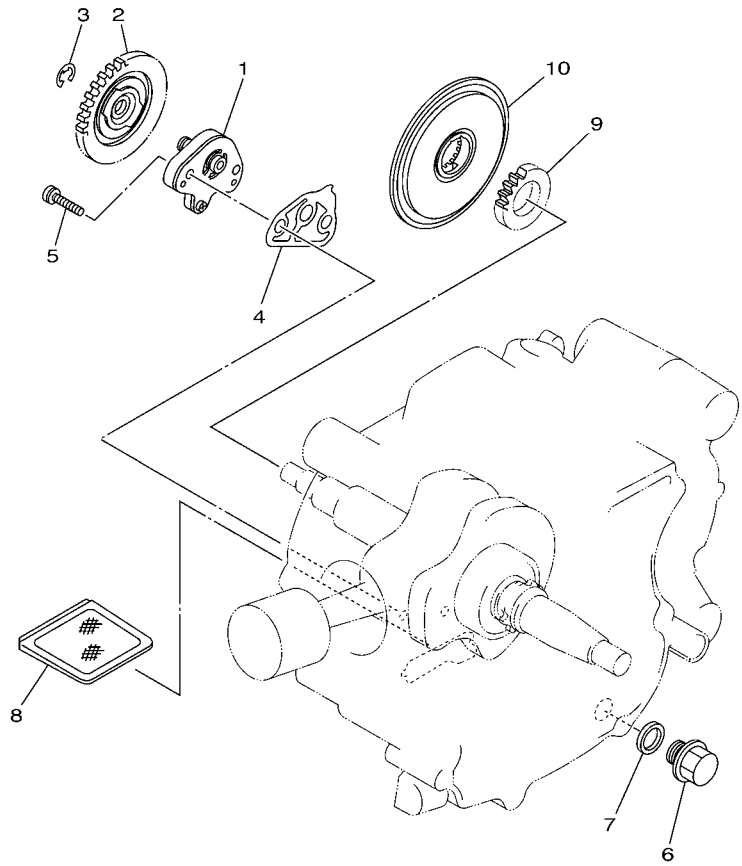

5TN1431-B050

REF. NO.	PART NO.	DESCRIPTION	SB6J				REMARKS
1	3S0-E3104-00	OIL PUMP SUB ASSY	1				
2	5TP-E3325-00	GEAR, PUMP DRIVEN	1				
3	99001-05600	CIRCLIP	1				
4	5TP-E3329-00	GASKET, PUMP COVER	1				
5	90155-06007	SCREW, FLAT FILLISTER	2				
6	90340-12808	PLUG, STRAIGHT SCREW	1				
7	4YS-E1198-00	GASKET	1				
8	4ST-E3411-00	STRAINER, OIL	1				
9	5TP-E3324-00	GEAR, PUMP DRIVE	1				
10	5TP-E3451-00	FILTER, ROTARY	1				

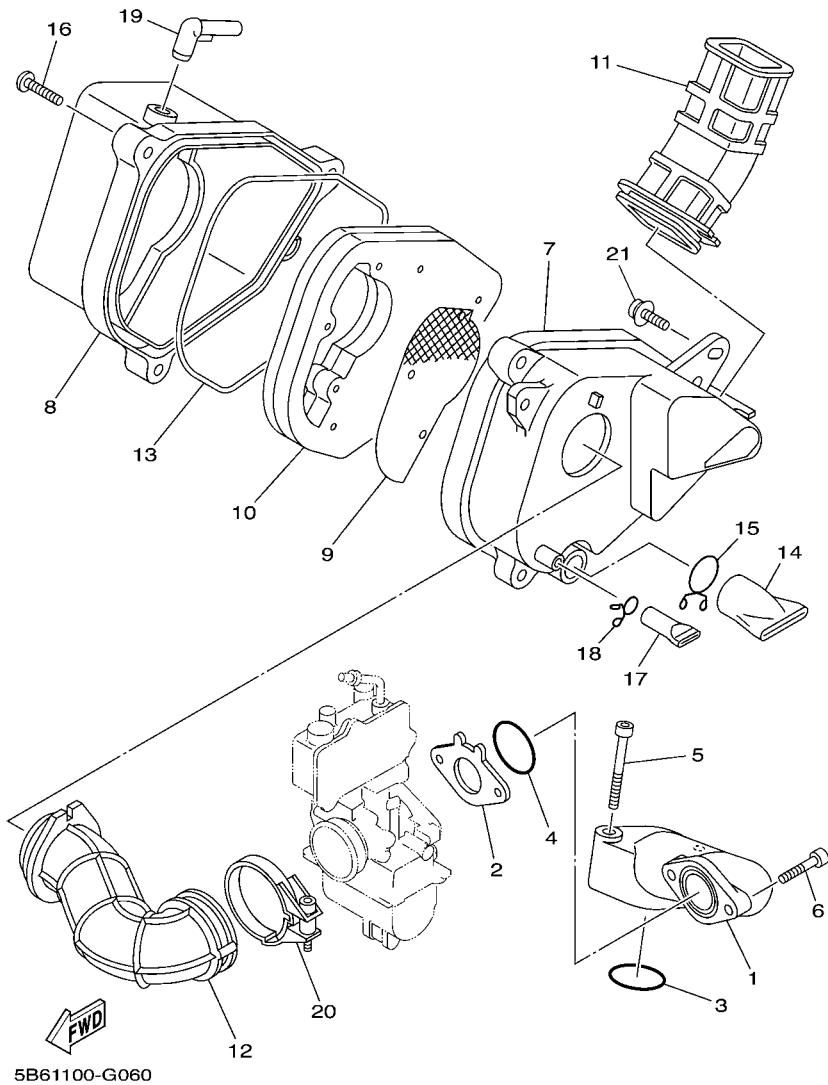

FIG. 6 INTAKE

REF. NO.	PART NO.	DESCRIPTION	5B6J				REMARKS
1	5B6-E3586-00	JOINT, CARBURETOR 1	1				
2	4GL-13595-01	JOINT	1				
3	93210-258G2	O-RING	1				
4	93210-25552	O-RING	1				
5	91317-06040	BOLT	2				
6	91317-06025	BOLT	2				
7	5B6-14411-00	CASE, AIR CLEANER 1	1				
8	5B6-14412-00	CAP, CLEANER CASE 1	1				
9	5B6-14472-00	PLATE, ELEMENT	1				
10	5B6-14451-00	ELEMENT, AIR CLEANER	1				
11	5B6-14437-00	DUCT	1				
12	5B6-14453-00	JOINT, AIR CLEANER 1	1				
13	3LD-14462-00	SEAL	1				
14	59V-14457-00	SEAL	1				
15	90467-22080	CLIP	1				
16	98907-06025	SCREW, BIND	3				
17	5XT-1443E-00	PIPE, DRAIN	1				
18	90467-11106	CLIP	1				
19	5Y1-14419-00	PIPE	1				
20	4TR-13474-01	BAND	1				
21	90159-06056	SCREW, WITH WASHER	2				

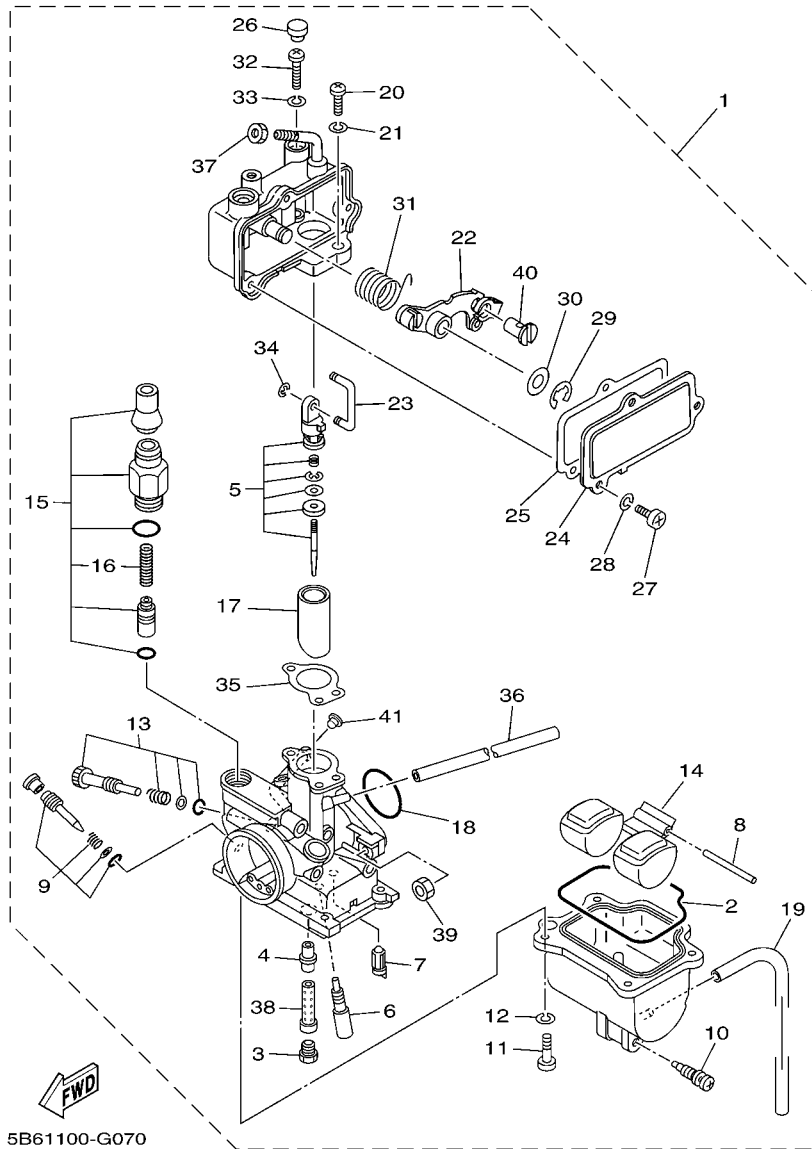
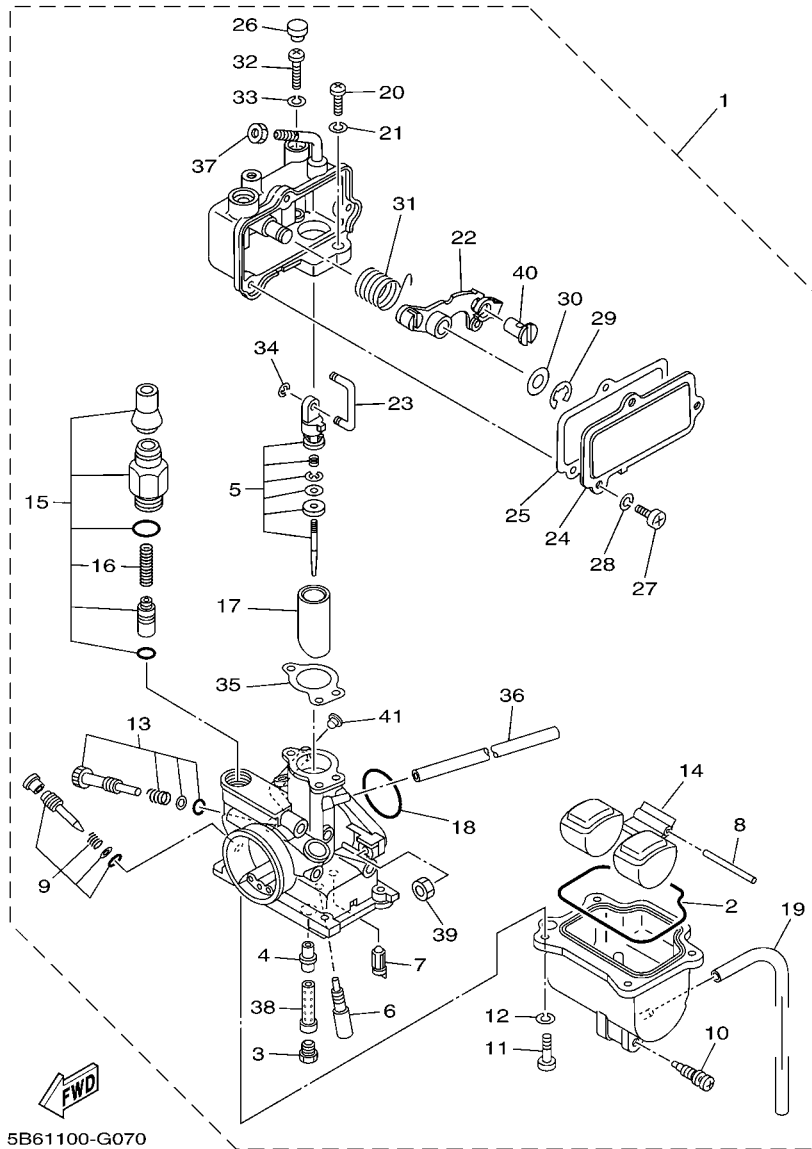

FIG. 7 CARBURETOR

REF. NO.	PART NO.	DESCRIPTION	5B6J				REMARKS
1	5B6-14101-10	CARBURETOR ASSY 1	1				
2	4GL-14239-00	.SEAL	1				
3	18A-14143-19	.JET, MAIN (# 95)	1				
4	5KA-14141-13	.NOZZLE, MAIN	1				
5	5B6-1490J-00	.NEEDLE SET	1				
6	2MM-14142-12	.JET, PILOT(#12.5)	1				
7	5DW-14150-00	.NEEDLE ASSY	1				
8	353-14186-00	.PIN, FLOAT	1				
9	5HN-14104-00	.AIR SCREW SET	1				
10	12R-14191-00	.PLUG, DRAIN	1				
11	98507-04014	.SCREW, PAN HEAD	4				
12	92907-04100	.WASHER, SPRING	4				
13	5DV-14103-00	.THROTTLE SCREW SET	1				
14	5HN-14985-00	.FLOAT	1				
15	5HN-1410A-00	.STARTER SET	1				
16	5HN-14135-00	..COIL, SPRING	1				
17	5B6-14112-25	.VALVE, THROTTLE 1	1				
18	241-14147-00	.O-RING	1				
19	4GL-14348-00	.PIPE 1	1				
20	98507-04012	.SCREW, PAN HEAD	1				
21	92907-04100	.WASHER, SPRING	1				
22	4GL-14292-10	.BRACKET 2	1				
23	4GL-14577-10	.ROD	1				
24	4GL-14293-00	.COVER 1	1				
25	4GL-14536-10	.GASKET	1				
26	3F7-14991-00	.PLUG, SCREW	1				
27	98507-04010	.SCREW, PAN HEAD	3				



5B61100-G070

FIG. 7 CARBURETOR

REF. NO.	PART NO.	DESCRIPTION	5B6J				REMARKS
28	92907-04100	.WASHER, SPRING	3				
29	812-14137-00	.CLIP	1				
30	1A8-14953-00	.WASHER	1				
31	4GL-14275-01	.SPRING	1				
32	98507-04016	.SCREW, PAN HEAD	1				
33	92907-04100	.WASHER, SPRING	1				
34	256-14919-00	.CLIP	1				
35	1V3-14126-00	.GASKET	1				
36	5YT-14193-00	.PIPE	1				
37	522-14161-00	.NUT, CABLE ADJUSTING	1				
38	5HN-14148-00	.PIPE	1				
39	5DV-14594-10	.NUT	2				
40	4GL-14155-10	.GUIDE, CABLE	1				
41	5LW-14994-00	.NET, FILTER	1				

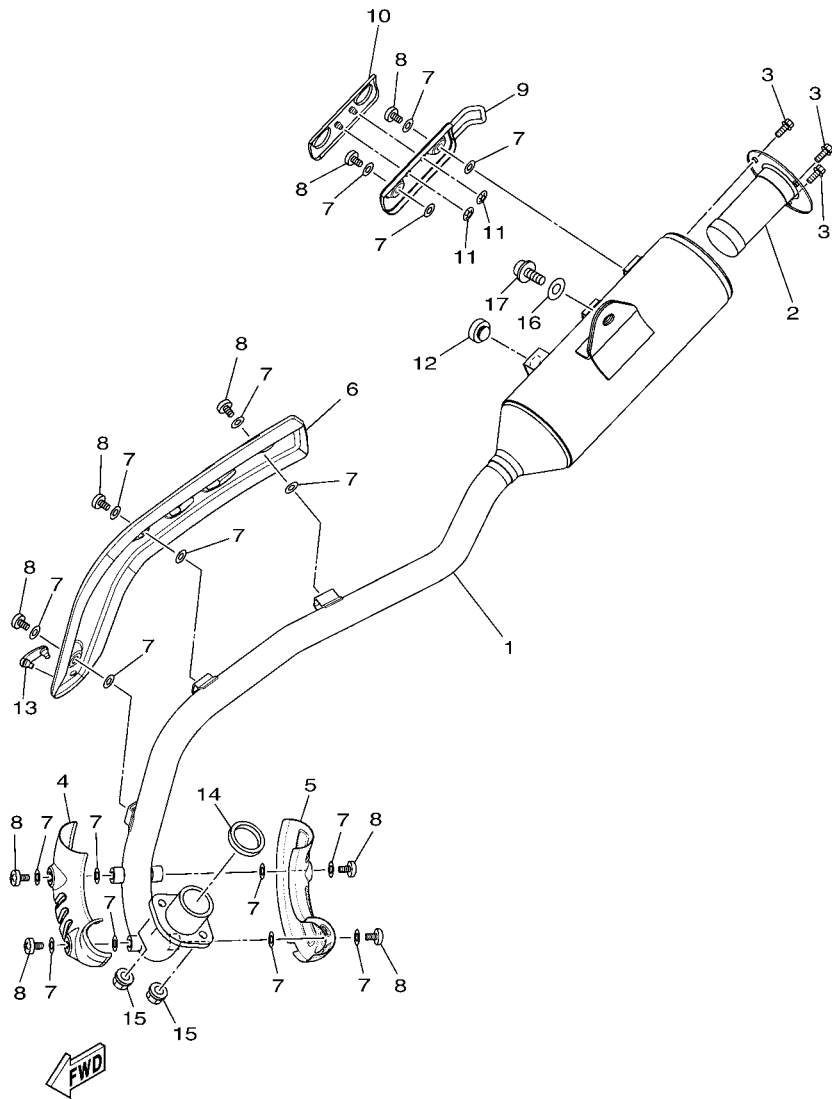

5B61100-G080

FIG. 8 EXHAUST

REF. NO.	PART NO.	DESCRIPTION	5B6J				REMARKS
1	5B6-14711-00	MUFFLER 1	1				
2	5B6-14780-00	SPARK ARRESTER ASSY	1				
3	95027-06010	BOLT, FLANGE	3				
4	5B6-14718-00	PROTECTOR, MUFFLER 1	1				
5	5B6-14728-00	PROTECTOR, MUFFLER 2	1				
6	5B6-14738-00	PROTECTOR, MUFFLER 3	1				
7	90201-05017	WASHER, PLATE	18				
8	98980-06008	SCREW, BIND	9				
9	5HP-14758-00	PROTECTOR, SILENCER	1				
10	5HP-1479J-00	COVER 2	1				
11	90183-04047	NUT, SPRING	2				
12	22W-24181-00	DAMPER, LOCATING 1	1				
13	5B6-1479H-00	COVER, 1	1				
14	3DM-14613-00	GASKET, EXHAUST PIPE	1				
15	95707-06500	NUT, FLANGE	2				
16	90201-08326	WASHER, PLATE	1				
17	90110-08097	BOLT, HEXAGON SOCKET HEAD	1				

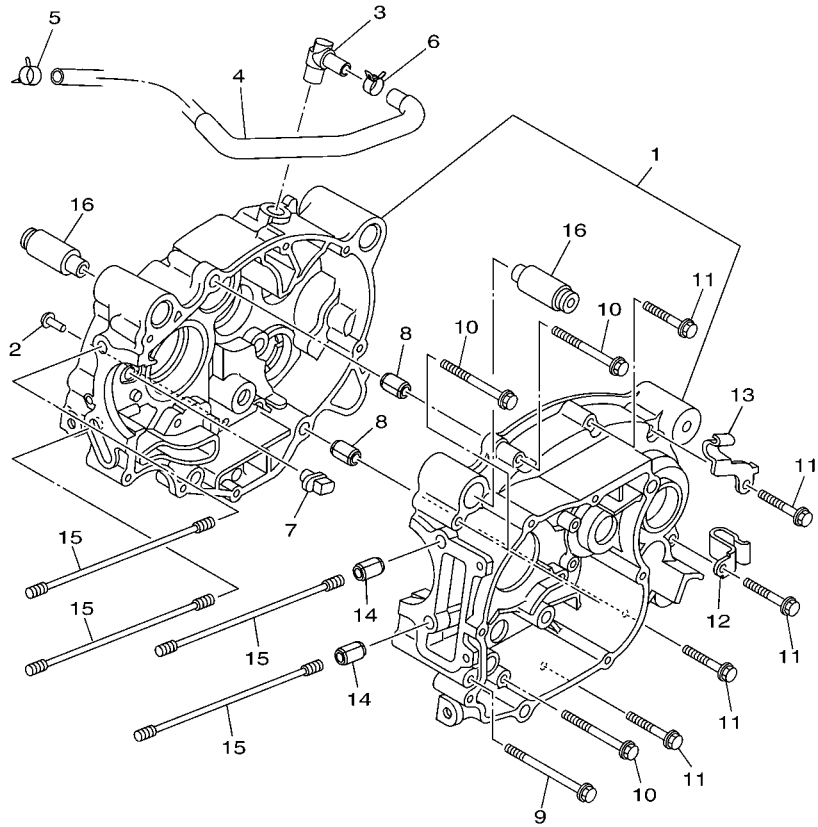

 5B61100-G090

FIG. 9 CRANKCASE

REF. NO.	PART NO.	DESCRIPTION	5B6J				REMARKS
1	3S0-E5150-01	CRANKCASE ASSY	1				
2	5HV-E6346-00	HOOK, SPRING	1				
3	5B6-E5371-00	BREATHER	1				
4	5B6-E1166-00	PIPE, BREATHER 1	1				
5	90467-13064	CLIP	1				
6	90467-13808	CLIP	1				
7	5TP-E5155-00	NOZZLE 3	1				
8	91810-14809	PIN, DOWEL	2				
9	9502L-06080	BOLT, FLANGE	1				
10	95022-06060	BOLT, FLANGE	3				
11	95022-06040	BOLT, FLANGE	5				
12	90465-10833	CLAMP	1				
13	90462-10801	CLAMP	1				
14	91810-14809	PIN, DOWEL	2				
15	90116-08807	BOLT, STUD	4				
16	5TP-E5316-00	DAMPER 1	2				

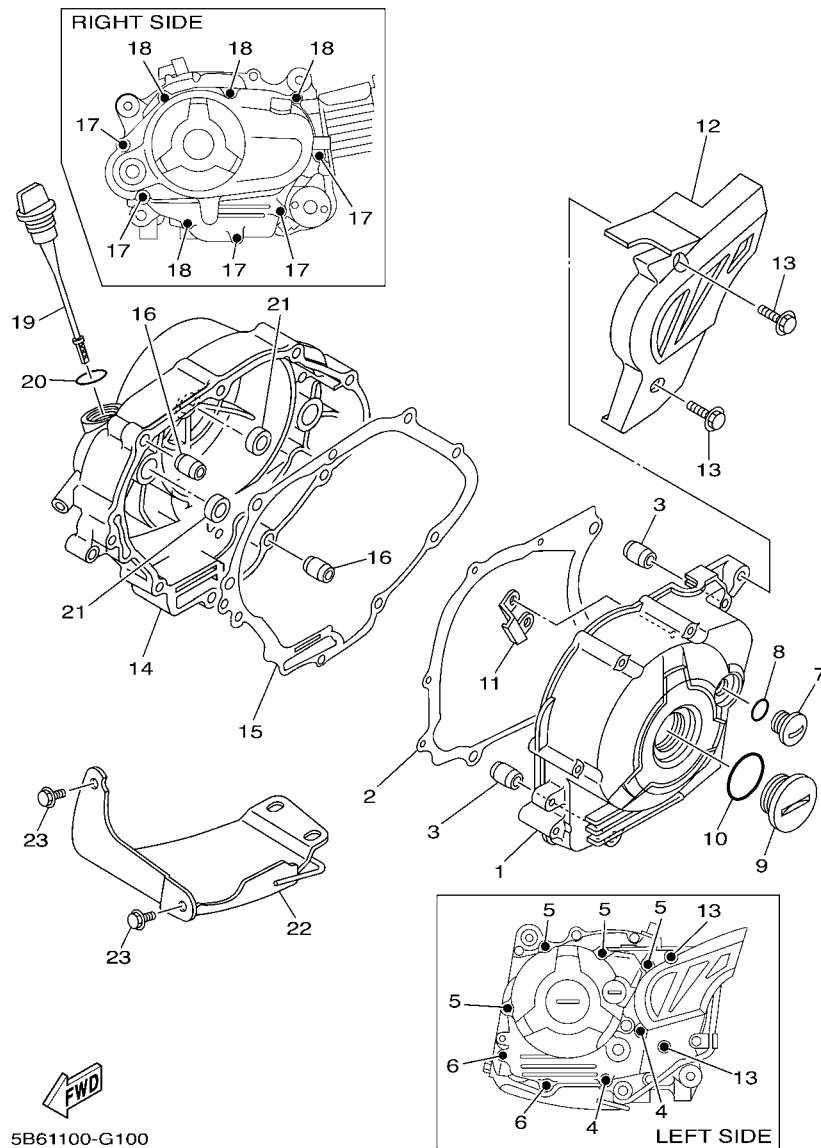
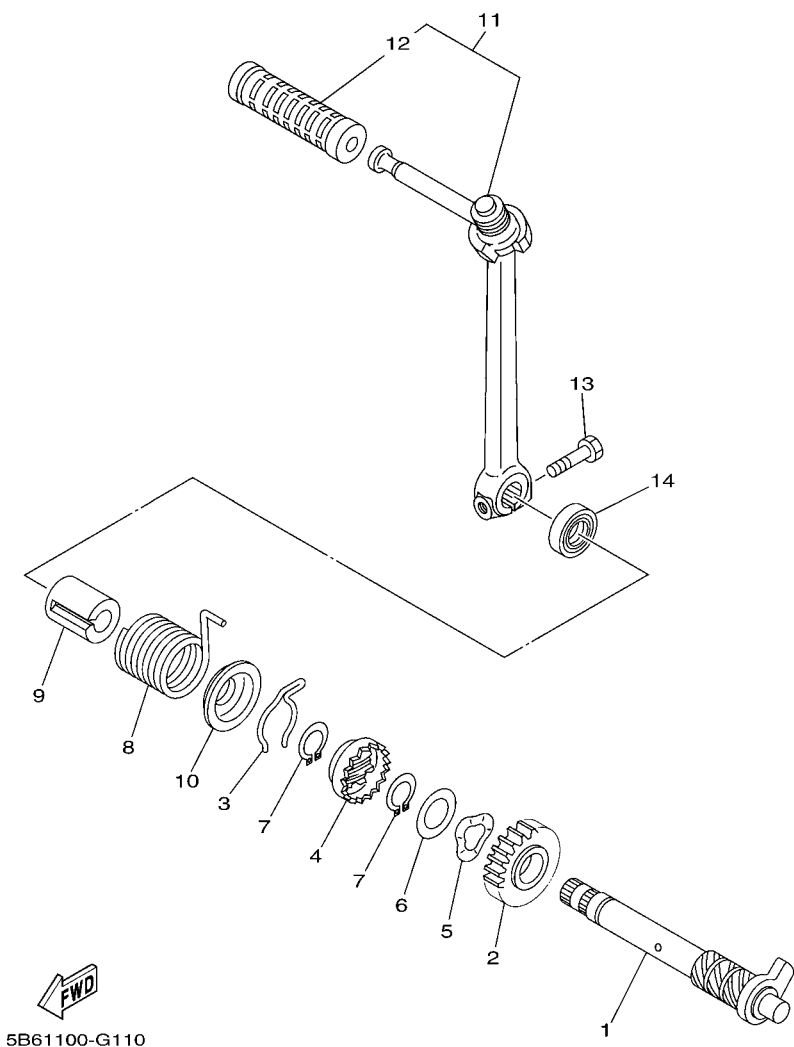

FIG. 10 CRANKCASE COVER 1

REF. NO.	PART NO.	DESCRIPTION	5B6J				REMARKS
1	5B6-E5411-00	COVER, CRANKCASE 1	1				
2	3S0-E5451-00	GASKET, CRANKCASE COVER 1	1				
3	91810-14809	PIN, DOWEL	2				
4	95022-06040	BOLT, FLANGE	2				
5	95022-06050	BOLT, FLANGE	4				
6	9502L-06080	BOLT, FLANGE	2				
7	90340-14812	PLUG, STRAIGHT SCREW	1				
8	93210-148F8	O-RING	1				
9	90340-32806	PLUG, STRAIGHT SCREW	1				
10	93210-328G3	O-RING	1				
11	5TP-E5113-00	PLATE	1				
12	5B6-15418-00	COVER, CHAIN CASE	1				
13	95022-06025	BOLT, FLANGE	2				
14	5B6-E5421-00	COVER, CRANKCASE 2	1				
15	4ST-E5461-11	GASKET, CRANKCASE COVER 2	1				
16	91810-14809	PIN, DOWEL	2				
17	95022-06040	BOLT, FLANGE	5				
18	95022-06050	BOLT, FLANGE	4				
19	5B6-E5362-00	PLUG, OIL LEVEL	1				
20	93210-198F9	O-RING	1				
21	93101-10843	OIL SEAL	2				
22	5B6-E5436-00	COVER, STARTING MOTOR	1				
23	95812-08016	BOLT, FLANGE	4				

FIG. 11 STARTER



REF. NO.	PART NO.	DESCRIPTION	5B6J				REMARKS
1	5TP-E5660-00	KICK AXLE ASSY	1				
2	5LM-E5641-00	GEAR, KICK	1				
3	90468-23194	CLIP	1				
4	4WH-E5671-00	WHEEL, RATCHET	1				
5	90206-19027	WASHER, WAVE	1				
6	4WH-E5644-00	SHIM	1				
7	99009-19400	CIRCLIP	2				
8	90508-26016	SPRING, TORSION	1				
9	3S0-E5664-00	GUIDE, SPRING	1				
10	5LM-E5664-00	GUIDE, SPRING	1				
11	5B6-15620-00	KICK CRANK ASSY	1				
12	156-15618-01	.COVER, KICK LEVER	1				
13	97017-06025	BOLT	1				
14	93102-15890	OIL SEAL	1				

FIG. 12 STARTER CLUTCH

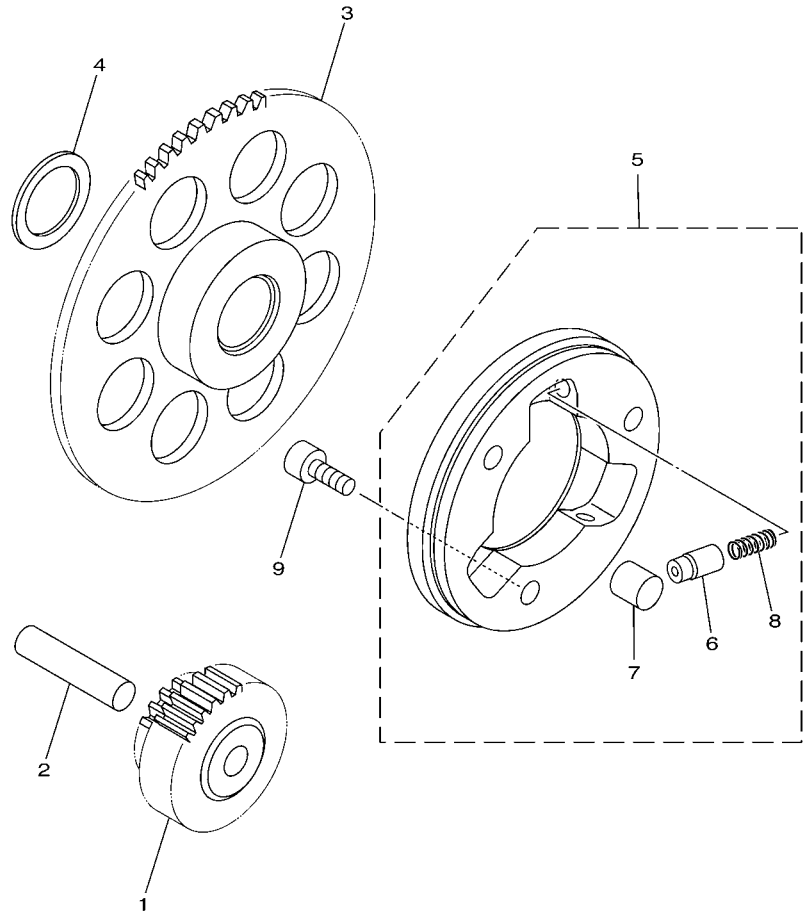

5TN1431-B120

REF. NO.	PART NO.	DESCRIPTION	5B6J					REMARKS
1	2P2-E5512-00	GEAR, IDLER 1	1					
2	93608-43157	PIN, DOWEL	1					
3	5TP-E5524-00	WHEEL, STARTER	1					
4	4WH-E5644-00	SHIM	1					
5	5HV-E5580-00	STARTER CLUTCH OUTER ASSY	1					
6	5HV-E5583-00	.CAP, STARTER CLUTCH SPRING	3					
7	93610-10174	.PIN, DOWEL	3					
8	90501-02639	.SPRING, COMPRESSION	3					
9	91317-06012	BOLT	3					

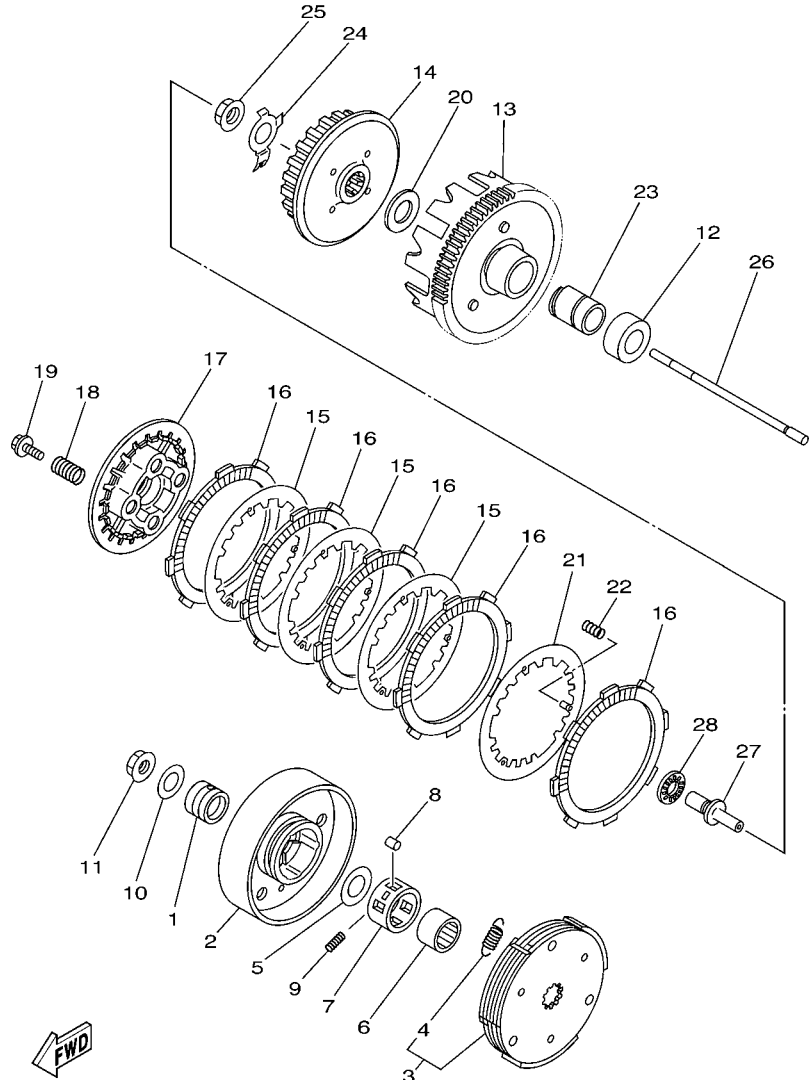

5TN3431-B130

FIG. 13 CLUTCH

REF. NO.	PART NO.	DESCRIPTION	5B6J				REMARKS
1	90387-16803	COLLAR	1				
2	2P2-E6611-00	CLUTCH HOUSING COMP.	1				
3	2P2-E6620-00	CLUTCH CARRIER ASSY	1				
4	2P2-E6626-00	.SPRING, CLUTCH WEIGHT 1	3				
5	90201-167P7	WASHER, PLATE	1				
6	5LM-E6512-00	BOSS, CLUTCH HOUSING	1				
7	5D9-E6586-00	CAGE	1				
8	93606-10800	PIN, DOWEL	3				
9	90501-04800	SPRING, COMPRESSION	1				
10	90201-12019	WASHER, PLATE	1				
11	90179-12659	NUT	1				
12	90560-17384	SPACER	1				
13	2P2-E6150-10	PRIMARY DRIVEN GEAR COMP.	1				
14	5B9-E6371-00	BOSS, CLUTCH	1				
15	2P2-E6324-00	PLATE, CLUTCH 1	3				
16	2P2-E6321-00	PLATE, FRICTION	5				
17	5B9-E6351-00	PLATE, PRESSURE 1	1				
18	90501-203G2	SPRING, COMPRESSION	4				
19	90119-05827	BOLT, WITH WASHER	4				
20	90201-178J5	WASHER, PLATE	1				
21	2P2-E6350-00	PRESSURE PLATE ASSY	1				
22	90501-050F1	SPRING, COMPRESSION	3				
23	90387-17004	COLLAR	1				
24	5TP-E6135-00	WASHER, LOCK	1				
25	90179-14001	NUT	1				
26	5LM-E6357-00	ROD, PUSH 2	1				
27	5LM-E6356-01	ROD, PUSH 1	1				

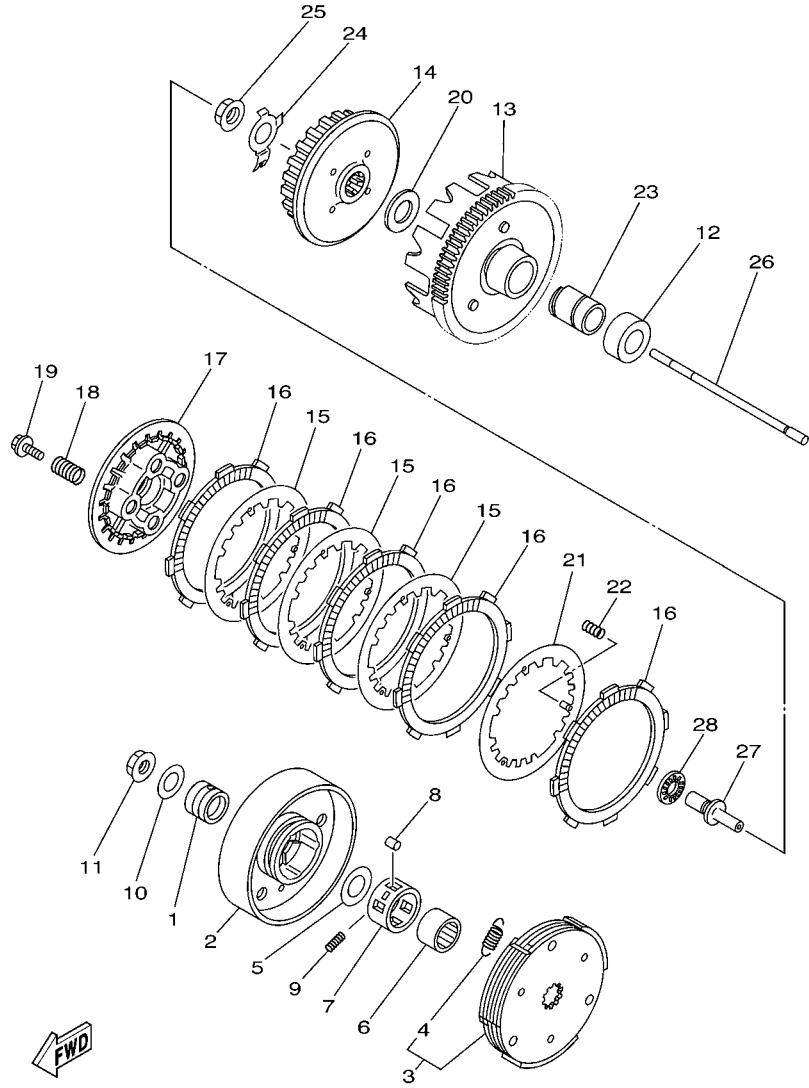

5TN3431-B130

FIG. 13 CLUTCH

REF. NO.	PART NO.	DESCRIPTION	5B6J				REMARKS
28	93340-210Y0	BEARING	1				

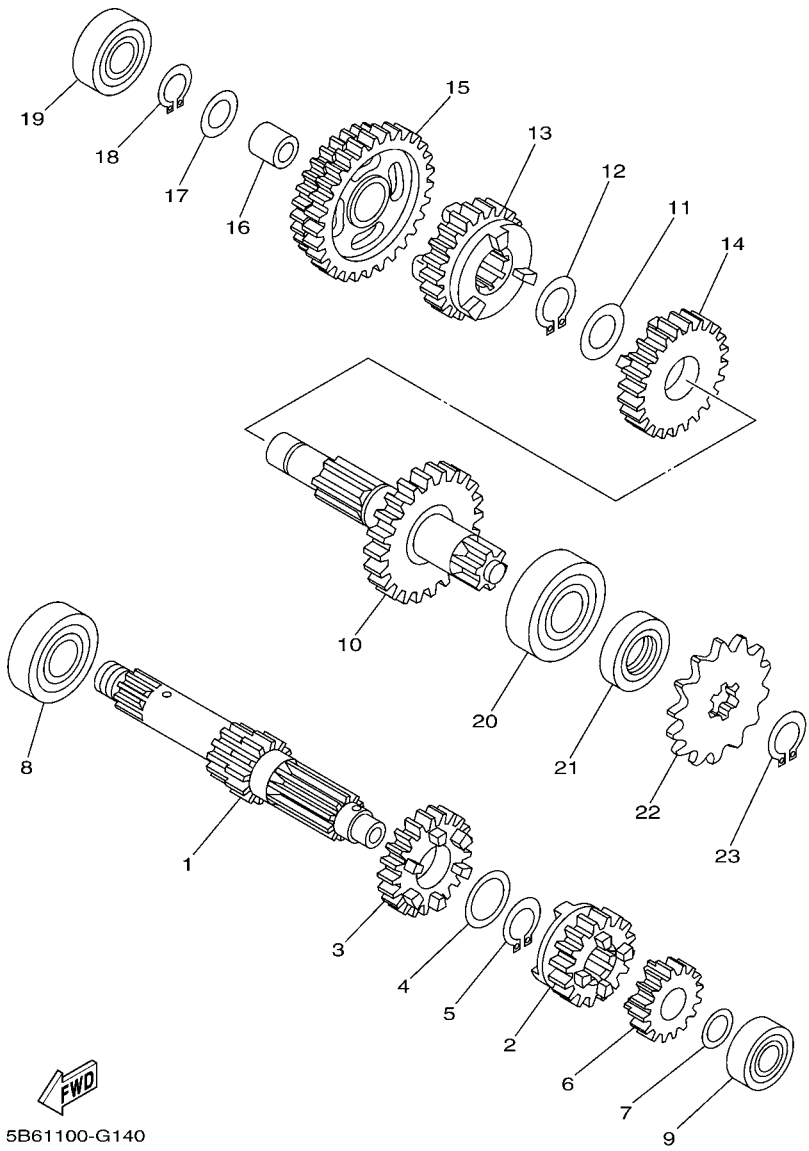

5B61100-G140

FIG. 14 TRANSMISSION

REF. NO.	PART NO.	DESCRIPTION	5B6J				REMARKS
1	4ST-E7411-00	AXLE, MAIN (12T)	1				
2	5TP-E7131-00	GEAR, 3RD PINION (21T)	1				
3	5TP-E7141-00	GEAR, 4TH PINION (21T)	1				
4	90201-20266	WASHER, PLATE (T=1.0)	1				
5	93410-20038	CIRCLIP	1				
6	5TP-E7121-00	GEAR, 2ND PINION (17T)	1				
7	90201-12166	WASHER, PLATE	1				
8	93306-203YR	BEARING	1				
9	93306-001Y7	BEARING	1				
10	5TP-E7402-00	DRIVE AXLE ASSY (33T)	1				
11	90201-20266	WASHER, PLATE (T=1.0)	1				
12	93410-20038	CIRCLIP	1				
13	5TP-E7241-00	GEAR, 4TH WHEEL (23T)	1				
14	5TP-E7231-00	GEAR, 3RD WHEEL (29T)	1				
15	5TP-E7211-00	GEAR, 1ST WHEEL (30T/38T)	1				
16	90387-1503D	COLLAR	1				
17	90201-15700	WASHER, PLATE	1				
18	99009-15400	CIRCLIP	1				
19	93306-202YW	BEARING	1				
20	93306-204YC	BEARING	1				
21	93102-20892	OIL SEAL	1				
22	93812-14814	SPROCKET, DRIVE (14T)	1				
23	93410-20038	CIRCLIP	1				

FIG. 15 SHIFT CAM & FORK

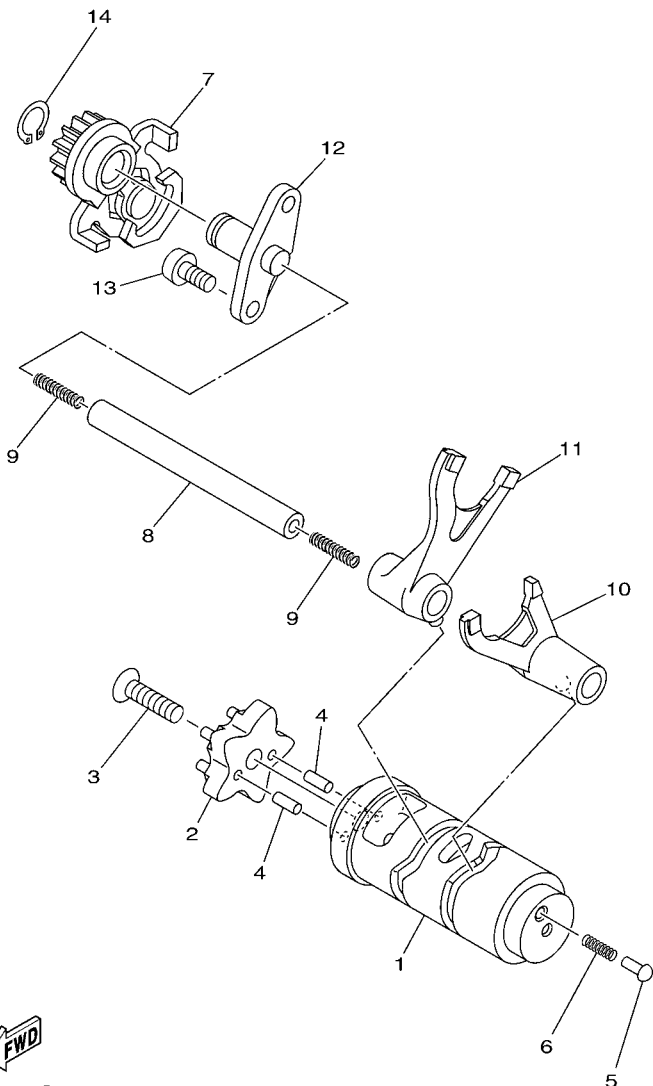

FWD
5B61100-G150

REF. NO.	PART NO.	DESCRIPTION	5B6J				REMARKS
1	5B6-E8540-00	SHIFT CAM ASSY	1				
2	2P2-E8185-00	SEGMENT	1				
3	90149-06N01	SCREW	1				
4	93604-12831	PIN, DOWEL	2				
5	4BA-18542-00	POINT, NEUTRAL	1				
6	90501-06022	SPRING, COMPRESSION	1				
7	5TP-E8120-00	SHIFT LEVER ASSY	1				
8	5TP-E8531-00	BAR, SHIFT FORK GUIDE 1	1				
9	90501-06800	SPRING, COMPRESSION	2				
10	5LM-E8511-00	FORK, SHIFT 1	1				
11	5LM-E8512-00	FORK, SHIFT 2	1				
12	5TP-E818A-00	BOSS	1				
13	92017-06016	BOLT, BUTTON HEAD	2				
14	99009-12400	CIRCLIP	1				

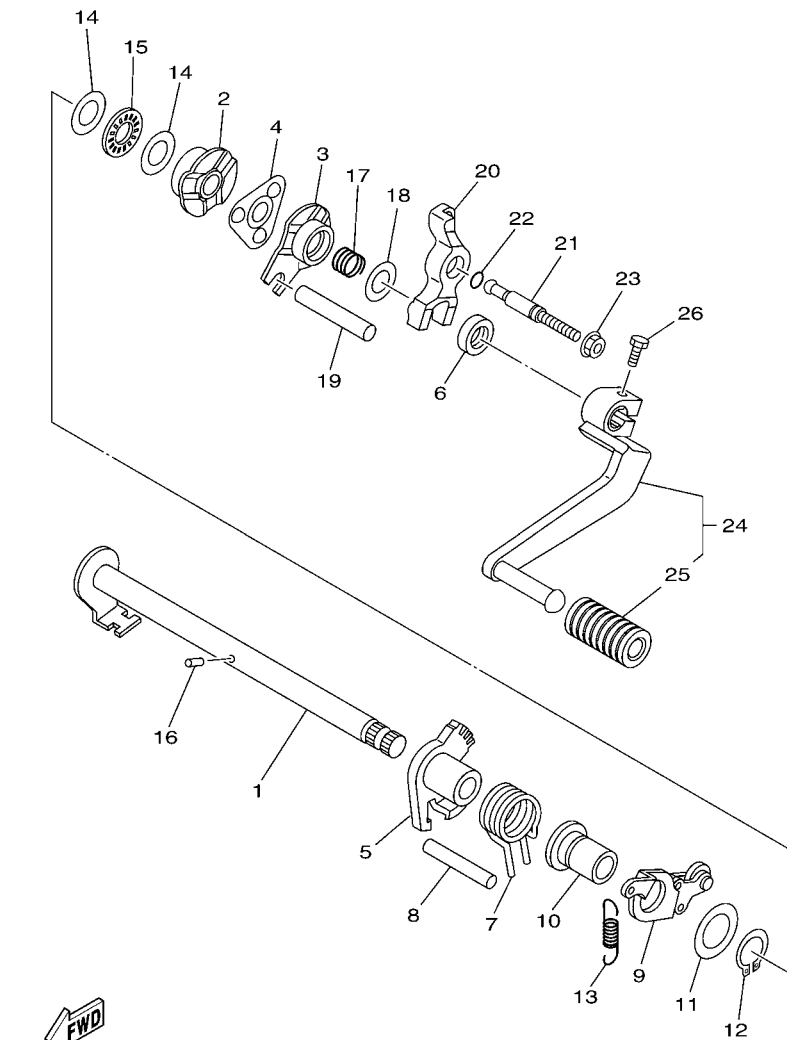

FWD
5B61100-G160

FIG. 16 SHIFT SHAFT

REF. NO.	PART NO.	DESCRIPTION	5B6J				REMARKS
1	5TP-E8101-00	SHIFT SHAFT ASSY	1				
2	5TP-E8179-00	GUIDE	1				
3	5TP-E8172-00	GUIDE, SHIFT	1				
4	5TP-E8181-00	HOLDER, PAWL	1				
5	5TP-E8152-10	LEVER, SHIFT 4	1				
6	93102-12891	OIL SEAL	1				
7	90508-29007	SPRING, TORSION	1				
8	93608-50149	PIN, DOWEL	1				
9	5TP-E8140-00	STOPPER LEVER ASSY	1				
10	5TP-E8699-00	BOSS 1	1				
11	90201-178D3	WASHER, PLATE	1				
12	99009-17400	CIRCLIP	1				
13	5TP-E8337-00	SPRING	1				
14	90201-127F4	WASHER, PLATE	2				
15	93340-212Y2	BEARING	1				
16	93604-10801	PIN, DOWEL	1				
17	90501-125E9	SPRING, COMPRESSION	1				
18	90201-126A7	WASHER, PLATE	1				
19	5LM-E8173-00	PIN, SHIFT	1				
20	2P2-E817A-00	ARM, SHIFT 3	1				
21	4YS-E8186-00	SCREW, ADJUSTING	1				
22	93210-068F7	O-RING	1				
23	95702-06500	NUT, FLANGE	1				
24	5B6-18110-00	SHIFT PEDAL ASSY	1				
25	132-18113-01	.COVER, SHIFT PEDAL	1				
26	97027-06020	BOLT, HEXAGON	1				

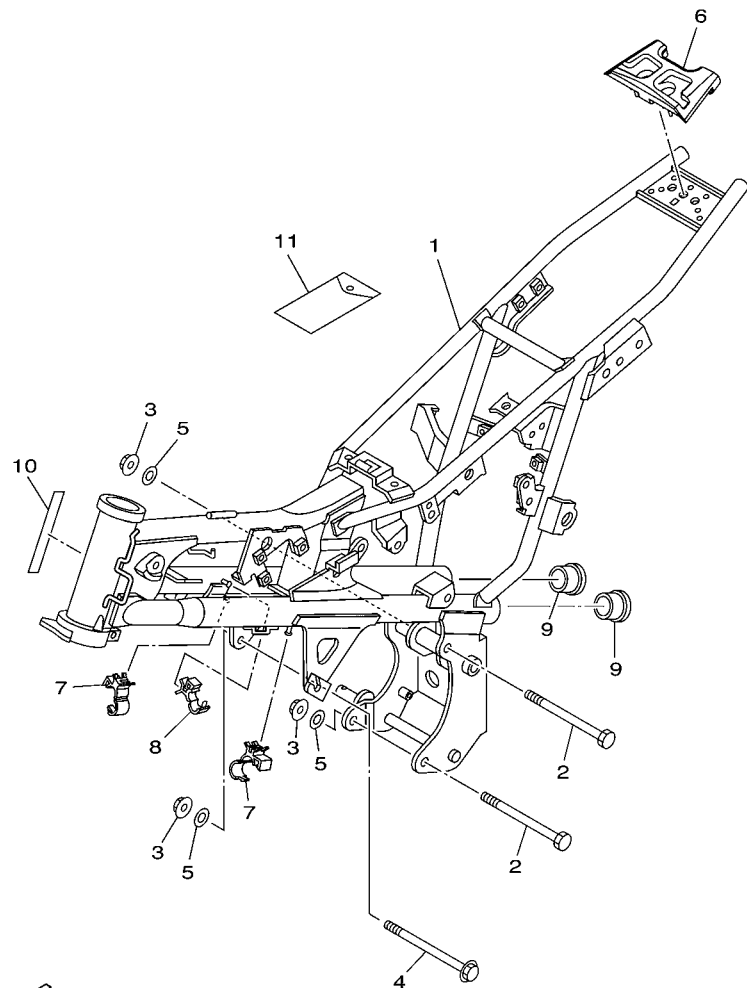

5B61110-G170

FIG. 17 FRAME

REF. NO.	PART NO.	DESCRIPTION	5B6J				REMARKS
1	5B6-21110-00	FRAME COMP.	1				
2	95812-08120	BOLT, FLANGE	2				
3	90179-08674	NUT	3				
4	90105-08223	BOLT, FLANGE	1				
5	90201-084K5	WASHER, PLATE	3				
6	5B6-2139X-00	DAMPER	1				
7	90464-15192	CLAMP	2				
8	90464-10190	CLAMP	1				
9	5B6-21279-00	PLUG, BLIND	2				
10	3HA-24141-00	PROTECTOR, FUEL TANK	1				
11	5HN-28100-00	TOOL KIT	1				

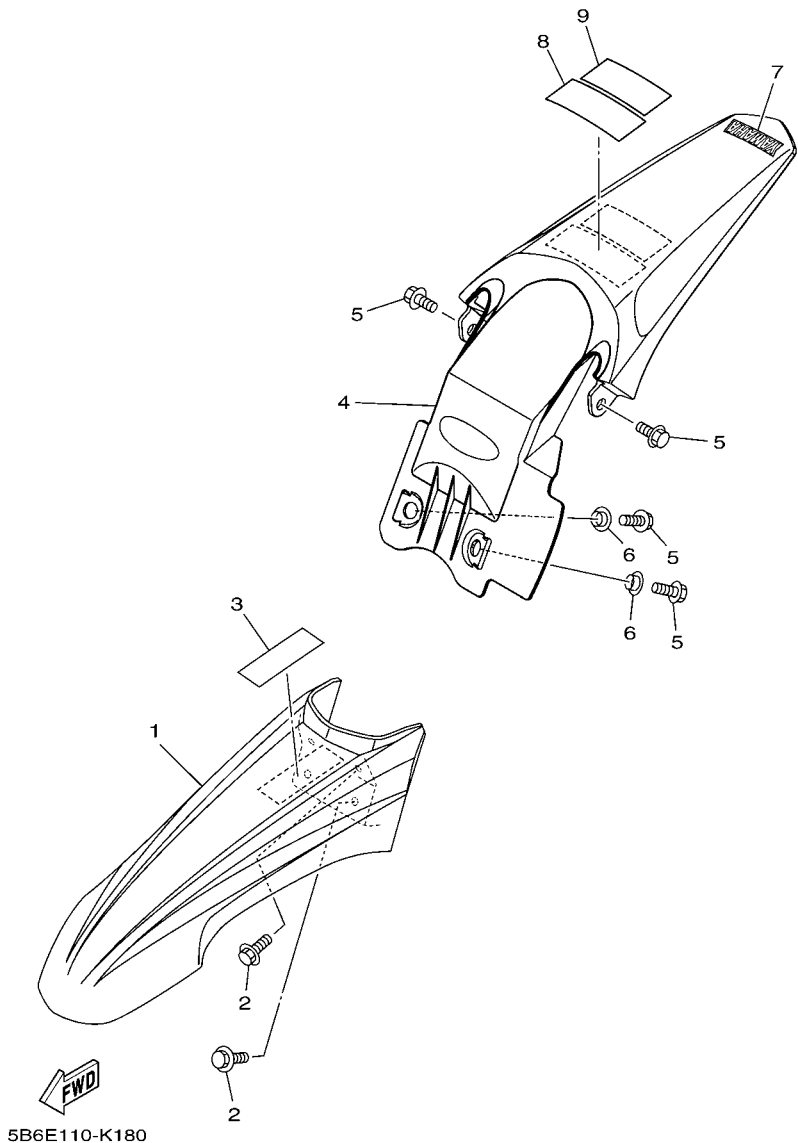

FIG. 18 FENDER

REF. NO.	PART NO.	DESCRIPTION	5B6J			REMARKS
1	5B6-21511-00	FENDER, FRONT	1			
2	90119-06051	BOLT, WITH WASHER	4			
3	3RV-21668-A0	LABEL, TIRE	1			
4	5B6-21610-00	REAR FENDER COMP.	1			
5	95802-06014	BOLT, FLANGE	4			
6	90387-06153	COLLAR	2			
7	5XC-2153E-00	EMBLEM, YAMAHA	1			
8	3PT-2118K-A1	LABEL, CAUTION	1			
9	5B6-2839Y-00	LABEL, CAUTION 2	1			

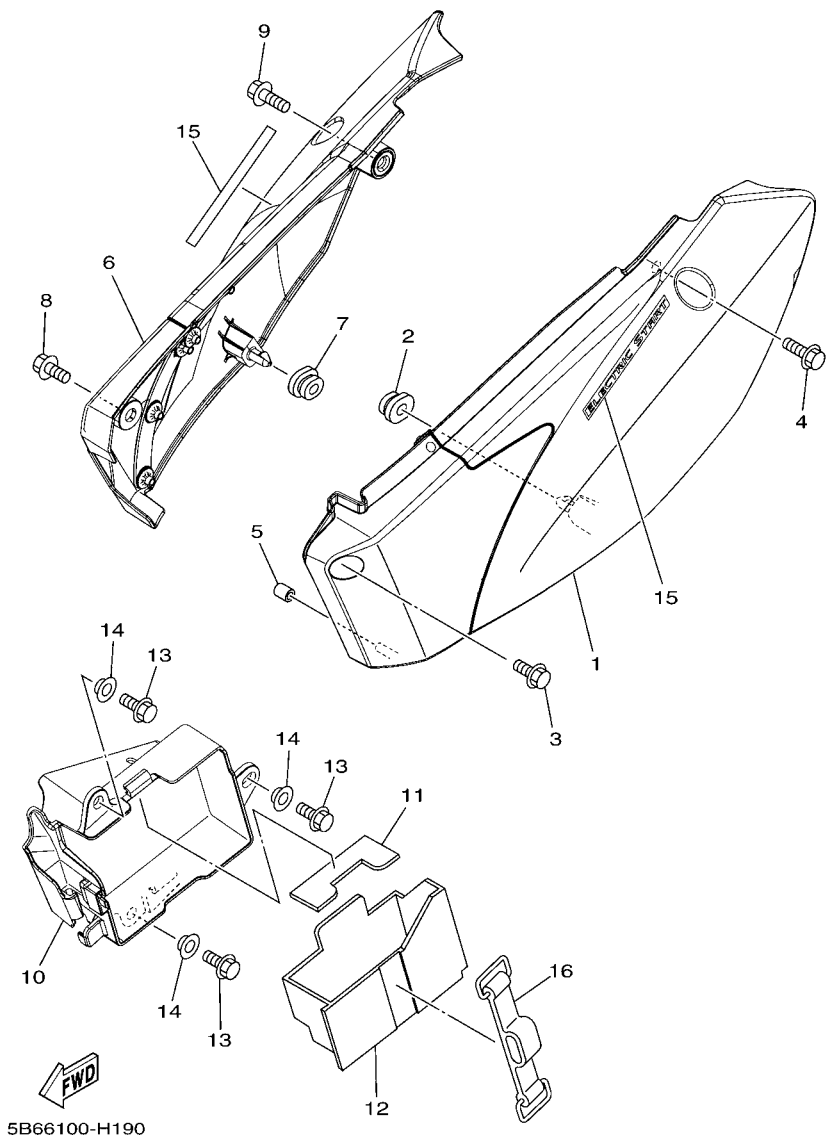
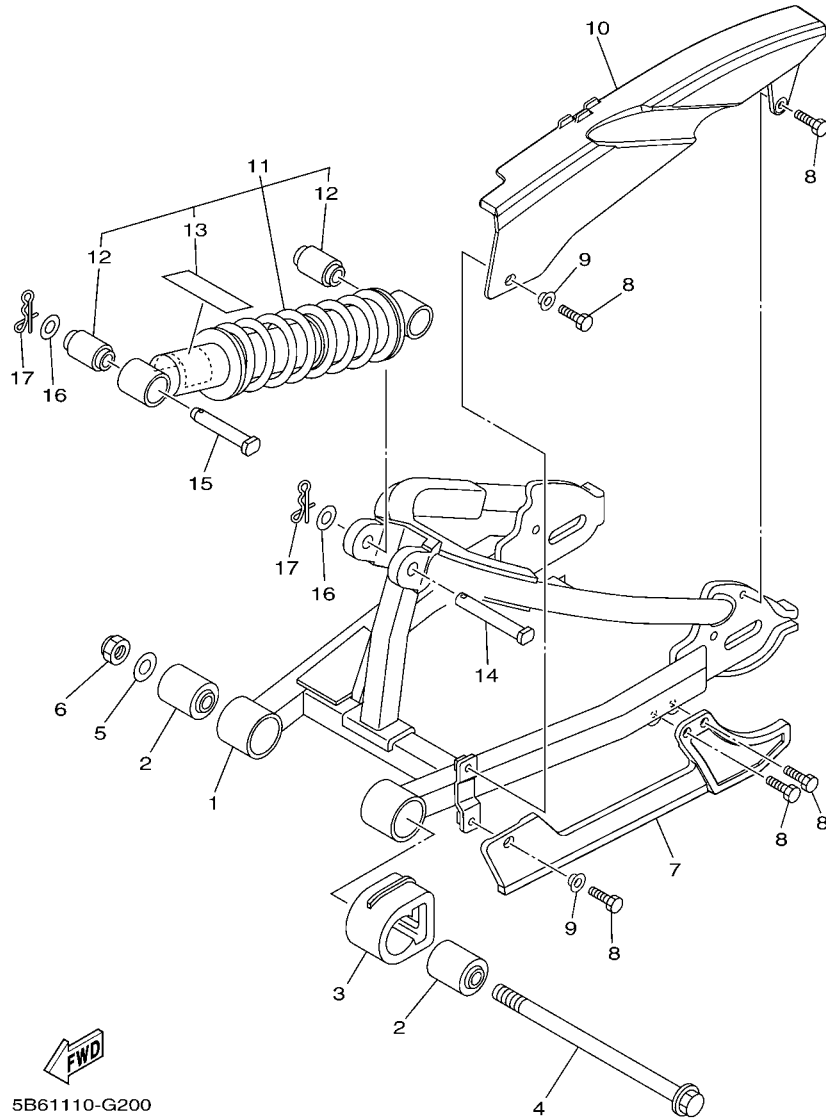

FIG. 19 SIDE COVER

REF. NO.	PART NO.	DESCRIPTION	5B6J				REMARKS
1	5B6-21710-00	SIDE COVER ASSY 1	1				
2	90480-01558	GROMMET	1				
3	95802-06014	BOLT, FLANGE	1				
4	95812-06016	BOLT, FLANGE	1				
5	5B6-21778-00	DAMPER, LOCATING 1	1				
6	5B6-21720-00	SIDE COVER ASSY 2	1				
7	90480-01558	GROMMET	1				
8	95802-06014	BOLT, FLANGE	1				
9	95812-06016	BOLT, FLANGE	1				
10	5B6-2177G-00	BOX, BATTERY	1				
11	5HN-21746-00	DAMPER	1				
12	5HN-2172W-00	COVER	1				
13	95802-06014	BOLT, FLANGE	3				
14	90387-06681	COLLAR	3				
15	5B6-21737-00	EMBLEM	2				
16	34M-82131-00	BAND, BATTERY	1				

FIG. 20 REAR ARM & SUSPENSION



5B61110-G200

REF. NO.	PART NO.	DESCRIPTION	5B6J				REMARKS
1	5B6-22110-00	REAR ARM COMP.	1				
2	5B6-22123-00	BUSH 1	2				
3	5B6-22151-00	SEAL, GUARD	1				
4	90105-12026	BOLT, FLANGE	1				
5	90201-127J6	WASHER, PLATE	1				
6	95617-12100	NUT, U	1				
7	5B6-22199-00	SUPPORT, CHAIN	1				
8	97027-05014	BOLT, HEXAGON	5				
9	90387-05021	COLLAR	2				
10	5B6-22311-00	CASE, CHAIN	1				
11	5B6-22210-00	SHOCK ABSORBER ASSY, REAR	1				
12	3M7-22216-00	.BUSH, REAR SHOCK ABSORBER	2				
13	4AA-22259-80	.LABEL, WARNING	1				
14	90240-10072	PIN, CLEVIS	1				
15	90240-10069	PIN, CLEVIS	1				
16	90201-106H5	WASHER, PLATE	2				
17	90468-20196	CLIP	2				

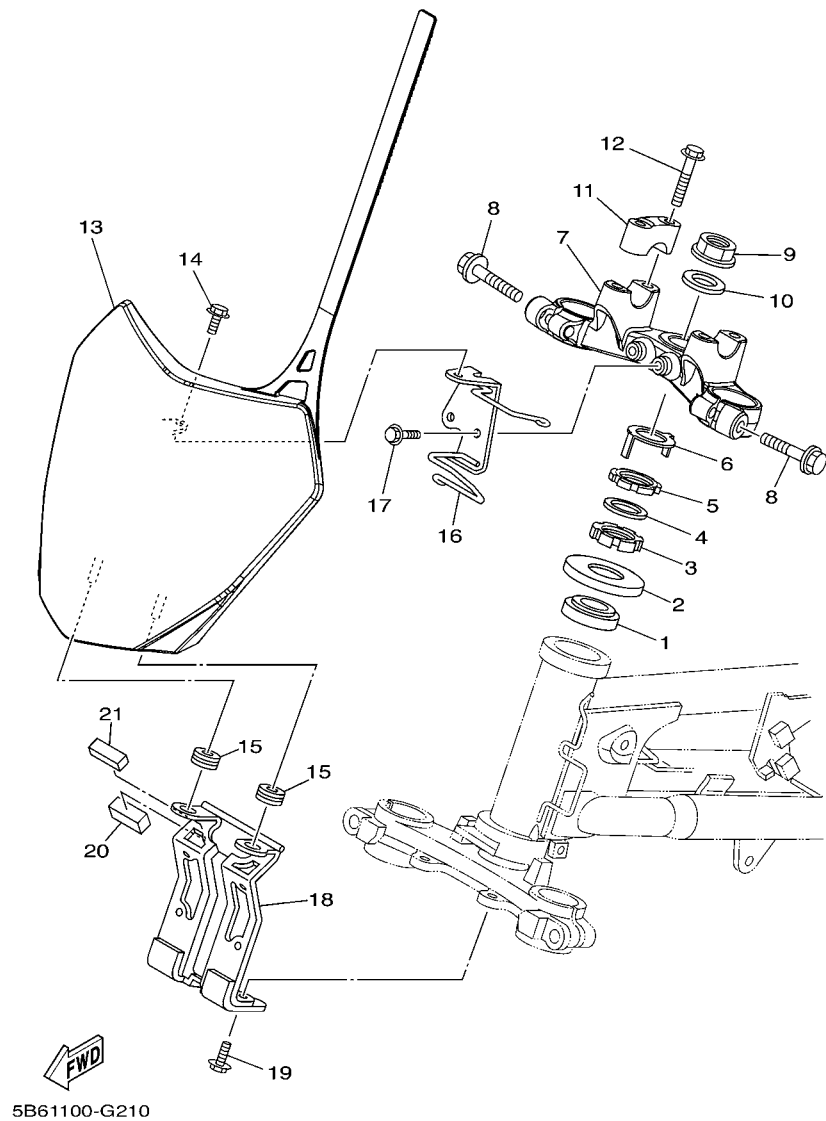

FIG. 21 STEERING

REF. NO.	PART NO.	DESCRIPTION	5B6J				REMARKS
1	93399-99949	BEARING	1				
2	5HP-23416-00	COVER, BALL RACE 2	1				
3	90179-25003	NUT	1				
4	90202-26142	WASHER, PLATE	1				
5	90179-25615	NUT	1				
6	3YF-23418-00	WASHER, SPECIAL	1				
7	5B6-23435-00	CROWN, HANDLE	1				
8	95022-08035	BOLT, FLANGE	2				
9	90179-22412	NUT	1				
10	90201-220T0	WASHER, PLATE	1				
11	1E6-23441-10-35	HOLDER, HANDLE UPPER	2				SL FOR DPBSE
12	95022-08035	BOLT, FLANGE	4				
13	5B6-23485-00	PLATE, NUMBER	1				
14	95802-06012	BOLT, FLANGE	1				
15	90480-13428	GROMMET	2				
16	5B6-2317E-00	STAY 1	1				
17	95802-06012	BOLT, FLANGE	2				
18	5B6-23486-00	STAY, PLATE	1				
19	95802-06012	BOLT, FLANGE	2				
20	5B6-23445-00	DAMPER	1				
21	5B6-23455-00	DAMPER	1				

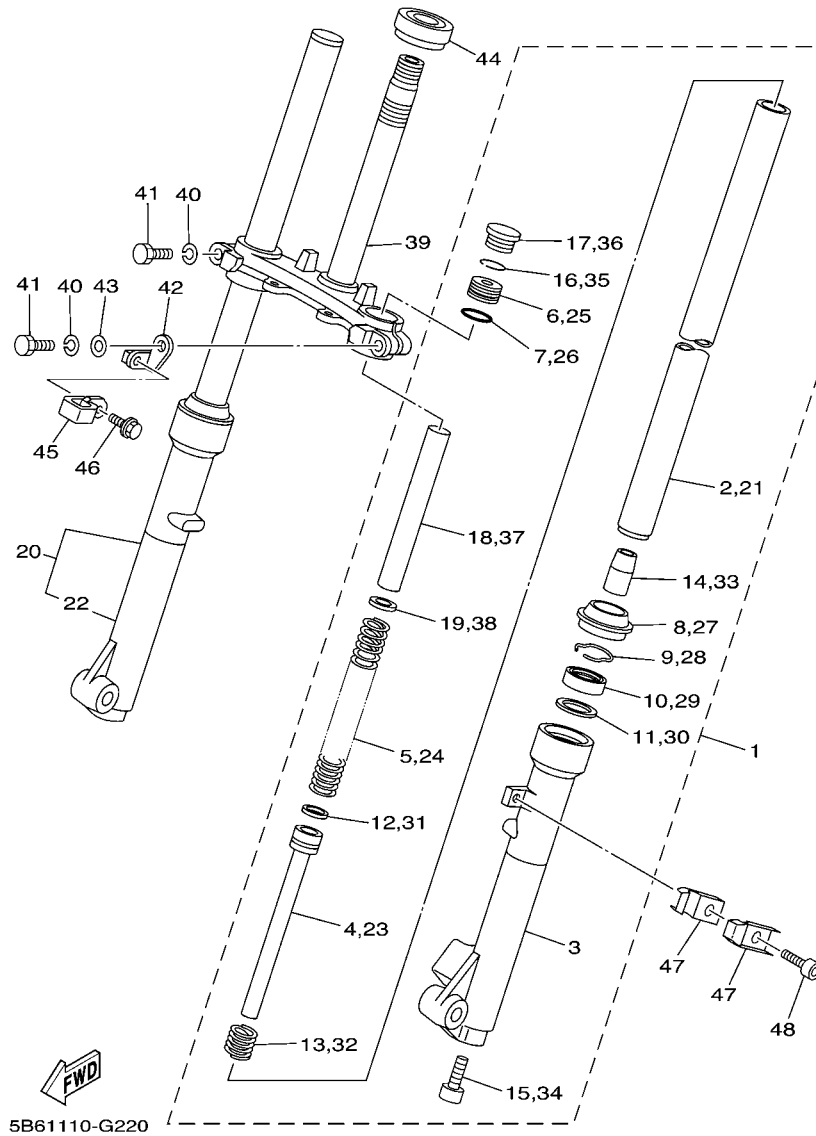

FIG. 22 FRONT FORK

REF. NO.	PART NO.	DESCRIPTION	5B6J				REMARKS
1	5B6-23102-00	FRONT FORK ASSY (L.H)	1				
2	5B6-23110-00	.INNER TUBE COMP.1	1				
3	5B6-23126-00	.TUBE, OUTER	1				
4	5B6-23170-00	.CYLINDER COMP., FRONT FORK	1				
5	5B6-23141-00	.SPRING, FRONT FORK	1				
6	5B6-2319U-00	.CAP	1				
7	5B6-23147-00	.O-RING	1				
8	5B6-23144-00	.SEAL, DUST	1				
9	2A6-23156-00	.RING, SNAP	1				
10	5B6-23145-00	.OIL SEAL	1				
11	5B6-23146-00	.WASHER, OIL SEAL	1				
12	5B6-23157-00	.RING, PISTON	1				
13	5B6-23151-00	.SPRING, REBOUND	1				
14	5B6-23173-00	.SPINDLE, TAPER	1				
15	1E7-23181-00	.BOLT, HEXAGON SOCKET HEAD	1				
16	1L9-23183-00	.RING, STOPPER	1				
17	3V2-23154-00	.CAP	1				
18	5B6-23118-00	.SPACER	1				
19	5B6-23149-00	.WASHER, SPRING UPPER	1				
20	5B6-23103-00	FRONT FORK ASSY (R.H)	1				
21	5B6-23110-00	.INNER TUBE COMP.1	1				
22	5B6-23136-00	.TUBE, OUTER	1				
23	5B6-23170-00	.CYLINDER COMP., FRONT FORK	1				
24	5B6-23141-00	.SPRING, FRONT FORK	1				
25	5B6-2319U-00	.CAP	1				
26	5B6-23147-00	.O-RING	1				
27	5B6-23144-00	.SEAL, DUST	1				

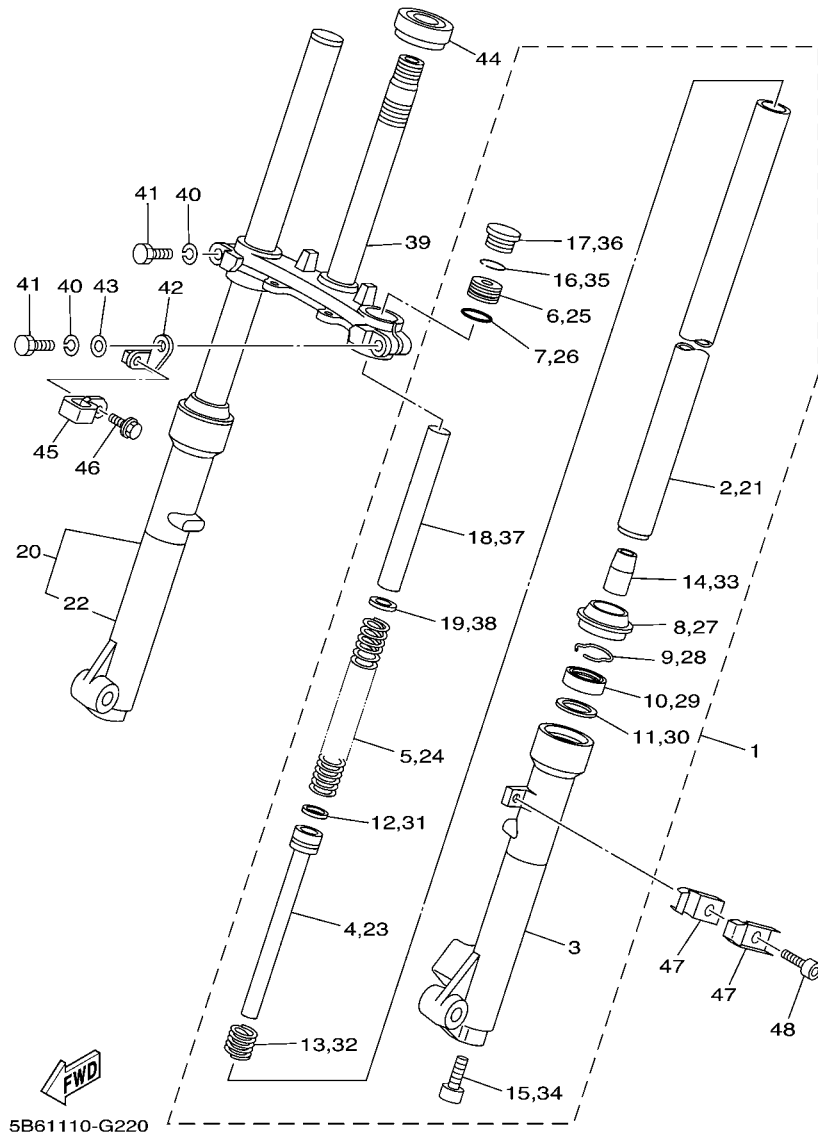

FIG. 22 FRONT FORK

REF. NO.	PART NO.	DESCRIPTION	5B6J				REMARKS
28	2A6-23156-00	.RING, SNAP	1				
29	5B6-23145-00	.OIL SEAL	1				
30	5B6-23146-00	.WASHER, OIL SEAL	1				
31	5B6-23157-00	.RING, PISTON	1				
32	5B6-23151-00	.SPRING, REBOUND	1				
33	5B6-23173-00	.SPINDLE, TAPER	1				
34	1E7-23181-00	.BOLT, HEXAGON SOCKET HEAD	1				
35	1L9-23183-00	.RING, STOPPER	1				
36	3V2-23154-00	.CAP	1				
37	5B6-23118-00	.SPACER	1				
38	5B6-23149-00	.WASHER, SPRING UPPER	1				
39	5B6-23340-00	UNDER BRACKET COMP.	1				
40	92901-10100	WASHER, SPRING	2				
41	451-23346-01	BOLT 1	2				
42	5B6-2334G-00	BRACKET 1	1				
43	92903-10600	WASHER, PLATE	1				
44	93332-00079	BEARING	1				
45	5HN-23857-00	HOLDER	1				
46	90105-05014	BOLT, FLANGE	1				
47	90462-14055	CLAMP	2				
48	91317-06012	BOLT	1				

FIG. 23 FUEL TANK

REF. NO.	PART NO.	DESCRIPTION	5B6J				REMARKS
1	5B6-24110-00	FUEL TANK COMP.	1				
2	2FJ-24610-10	CAP ASSY	1				
3	5B6-21826-10	PIPE, BREATHER	1				
4	1P6-24500-10	FUEL COCK ASSY 1	1				
5	1P6-24512-10	.GASKET	1				
6	90202-05193	WASHER, PLATE	2				
7	90149-06108	SCREW	2				
8	5B6-24311-00	PIPE, FUEL 1	1				
9	5B6-2411J-00	DAMPER, SIDE COVER	2				
10	5B6-24181-00	DAMPER, LOCATING 1	1				
11	90465-13152	CLAMP	2				
12	2X6-24183-00	DAMPER, LOCATING 3	1				
13	90467-09006	CLIP	2				
14	5B6-2137A-00	SCOOP AIR ASSY. 1	1				
15	90105-06064	BOLT, FLANGE	2				
16	90269-07076	RIVET	2				
17	5B6-2137B-00	SCOOP AIR ASSY. 2	1				
18	90105-06064	BOLT, FLANGE	2				
19	90269-07076	RIVET	2				
20	5B6-24157-00	STAY, FUEL TANK 1	1				
21	5B6-24158-00	STAY, FUEL TANK 2	1				
22	95802-06010	BOLT, FLANGE	4				
23	90480-18290	GROMMET	2				
24	90387-066J1	COLLAR	2				
25	90464-13003	CLAMP	1				
26	95802-06030	BOLT, FLANGE	2				
27	5B6-24116-00	STAY, FUEL TANK 2	1				

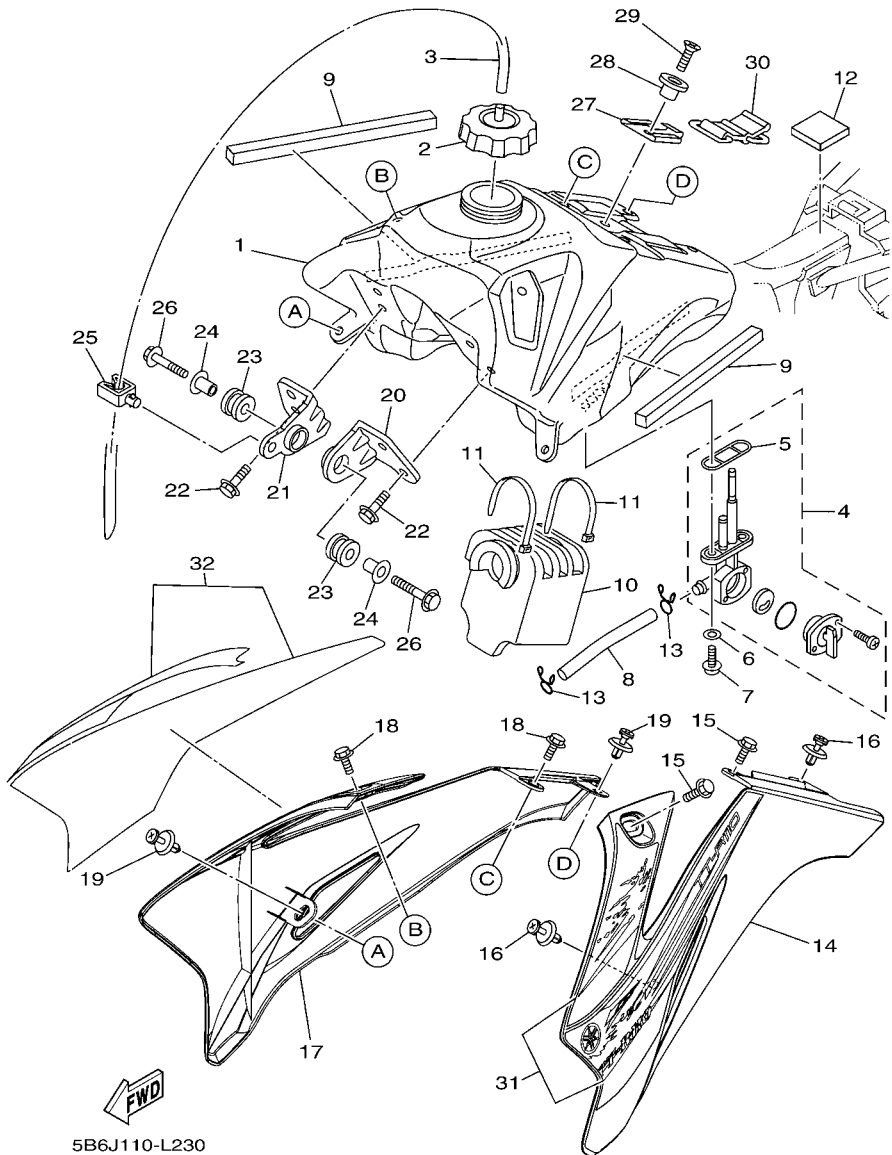
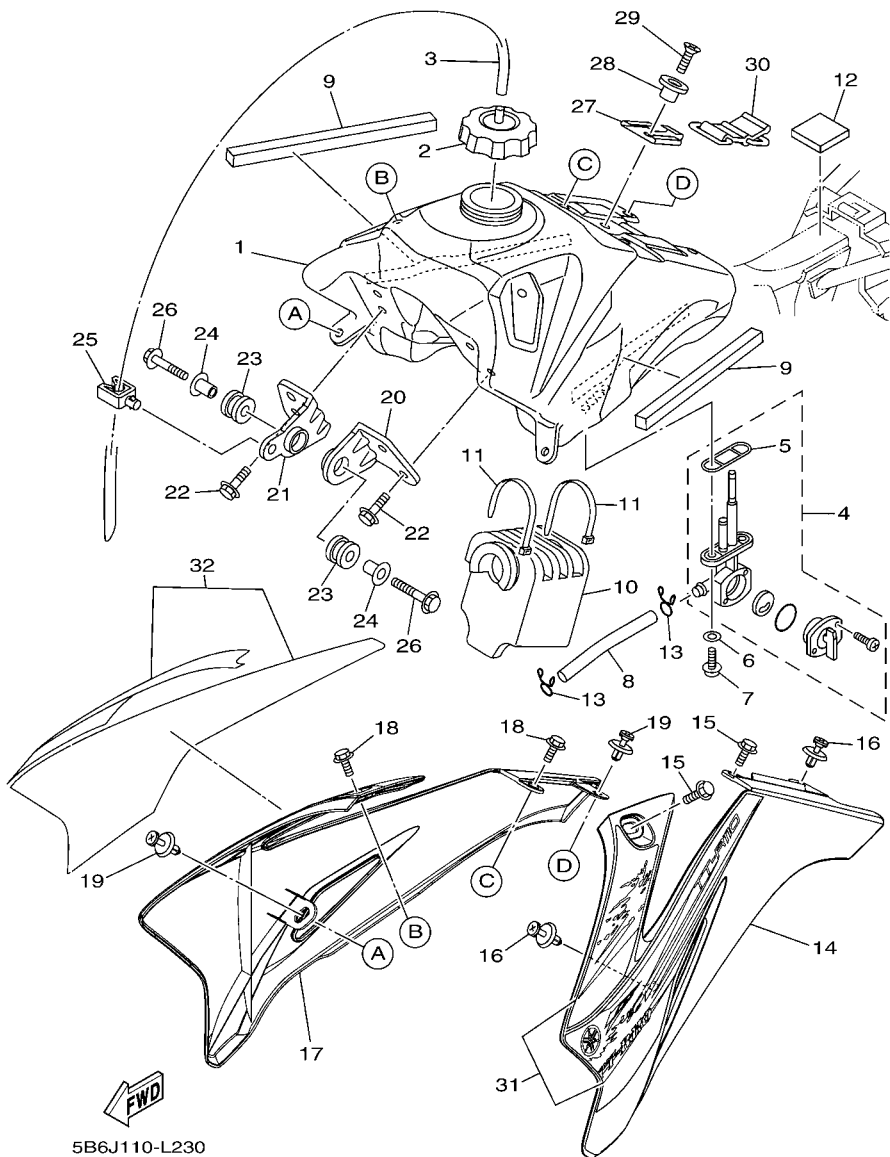

FIG. 23 FUEL TANK



5B6J110-L230

REF. NO.	PART NO.	DESCRIPTION	5B6J				REMARKS
28	4EW-2412F-00	BRACKET, SEAT	1				
29	98702-06025	SCREW, FLAT HEAD	1				
30	5B6-24173-00	BAND, TANK FITTING 1	1				
31	5B6-24230-30	GRAPHIC SET 1	1				
32	5B6-24250-30	GRAPHIC SET 2	1				

FIG. 24 SEAT

REF. NO.	PART NO.	DESCRIPTION	SB6J				REMARKS
1	5B6-24710-00	SINGLE SEAT ASSY	1				
2	5B6-2470F-00	.SEAT COVER COMP.	1				

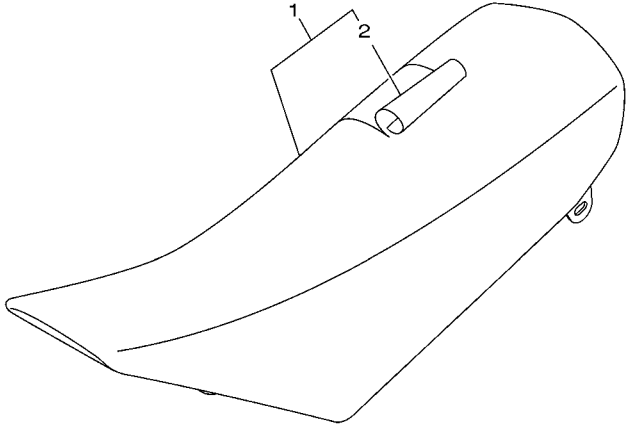

 5B61100-G240

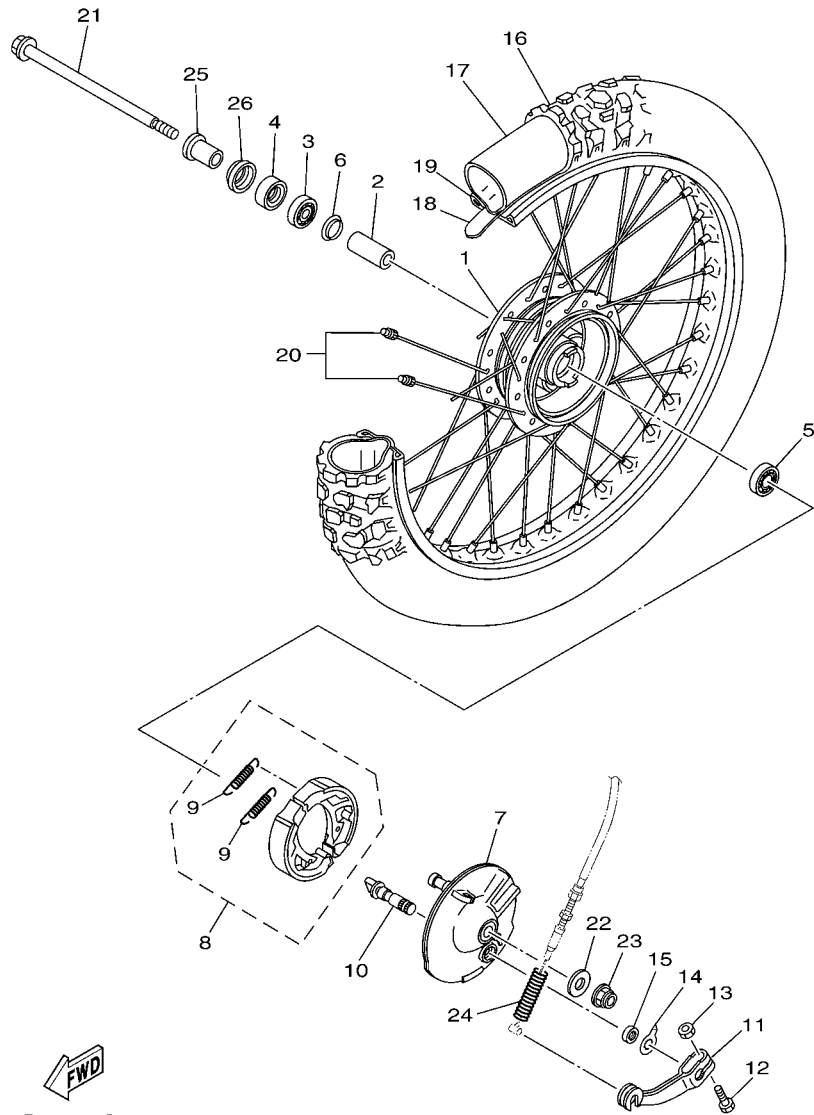

5B61100-G250

FIG. 25 FRONT WHEEL

REF. NO.	PART NO.	DESCRIPTION	5B6J				REMARKS
1	451-25111-00-35	HUB, FRONT	1				SL FOR DPBSE
2	90560-10103	SPACER	1				
3	93306-20004	BEARING	1				
4	93106-17006	OIL SEAL	1				
5	93306-20009	BEARING	1				
6	2E9-25116-00	FLANGE, SPACER 2	1				
7	5B6-25121-00-35	PLATE, BRAKE SHOE	1				SL FOR DPBSE
8	5B6-W253A-00	BRAKE SHOE KIT	1				
9	90506-14081	.SPRING, TENSION	2				
10	5B6-25151-00	CAMSHAFT	1				
11	451-25155-00	LEVER, CAMSHAFT 1	1				
12	90101-06291	BOLT	1				
13	95307-06600	NUT	1				
14	3L8-2513A-00	PLATE, INDICATOR	1				
15	93104-10001	OIL SEAL	1				
16	94125-141A6	TIRE (2.50-14 2PR)	1				CHENG SHIN
17	94225-14215	TUBE (2.25/2.50-14 TR4)	1				CHENG SHIN
18	94325-14129	BAND, RIM (2.50-14)	1				CHENG SHIN
19	94414-14227	RIM (1.40-14)	1				
20	3R0-25104-00	SPOKE SET, FRONT	1				
21	5B6-25181-00	AXLE, WHEEL	1				
22	92902-10200	WASHER	1				
23	95602-10200	NUT, U FLANGE	1				
24	90501-123A0	SPRING, COMPRESSION	1				
25	90387-10744	COLLAR	1				
26	451-25118-00	COVER, HUB DUST	1				

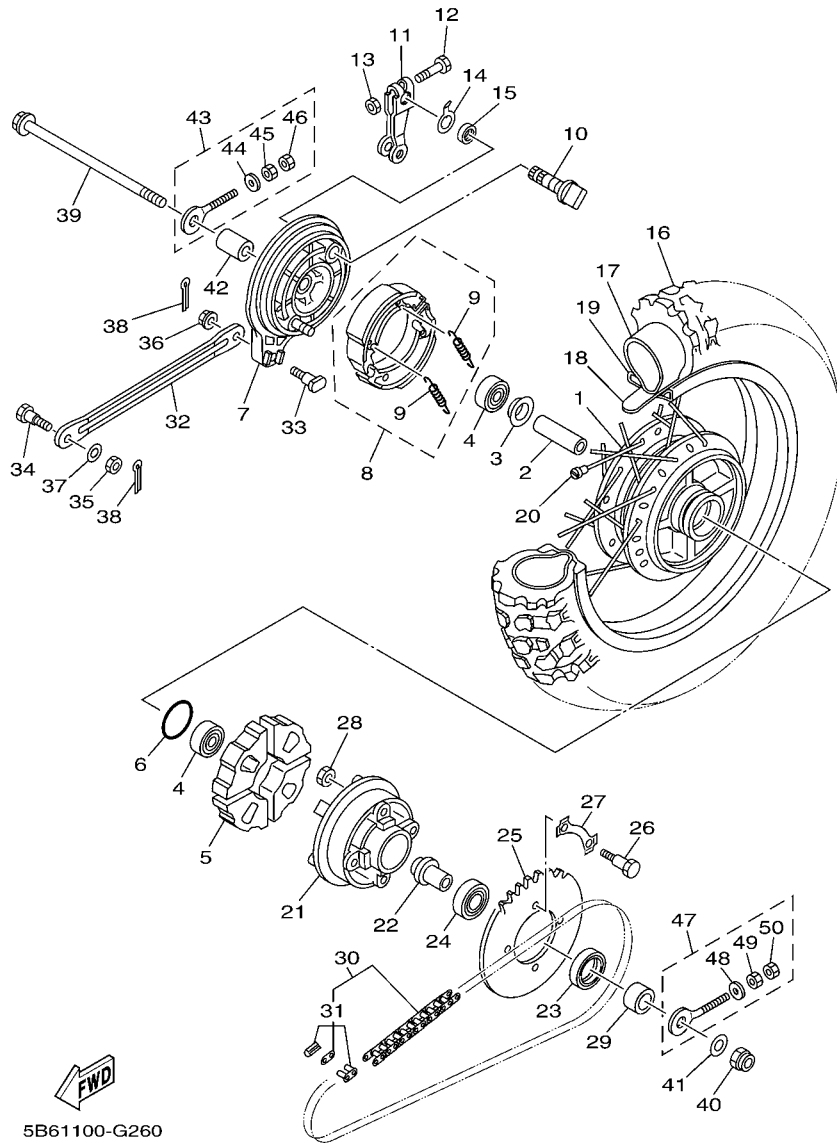

5B61100-G260

FIG. 26 REAR WHEEL

REF. NO.	PART NO.	DESCRIPTION	5B6J			REMARKS
1	21W-25311-00-35	HUB, REAR	1			SL FOR DPBSE
2	90560-12145	SPACER	1			
3	102-25315-00	FLANGE, SPACER	1			
4	93306-30111	BEARING	2			
5	21W-25364-00	DAMPER	4			
6	93210-41041	O-RING	1			
7	5B6-25321-00-35	PLATE, BRAKE SHOE	1			SL FOR DPBSE
8	4BE-W253E-00	BRAKE SHOE KIT	1			
9	90506-15260	.SPRING, TENSION	2			
10	3Y6-25351-00	CAMSHAFT	1			
11	538-25355-00	LEVER, CAMSHAFT	1			
12	90101-06278	BOLT	1			
13	95307-06600	NUT	1			
14	3Y6-2533A-01	PLATE, INDICATOR	1			
15	93109-14021	OIL SEAL	1			
16	94130-121A7	TIRE (3.00-12 2PR)	1			CHENG SHIN
17	94227-12216	TUBE (2.75/3.00-12 TR4)	1			CHENG SHIN
18	94330-12130	BAND, RIM (3.00-12)	1			CHENG SHIN
19	94416-12002	RIM (1.60-12)	1			
20	21W-25304-00	SPOKE SET, REAR	1			
21	296-25366-01-35	CLUTCH, HUB	1			SL FOR DPBSE
22	21W-25387-00	AXLE, SPROCKET	1			
23	93106-30004	OIL SEAL	1			
24	93306-00416	BEARING	1			
25	5A7-25435-01	SPROCKET, DRIVEN (35T)	1			
26	90101-08672	BOLT	4			
27	4AW-25412-00	WASHER	2			

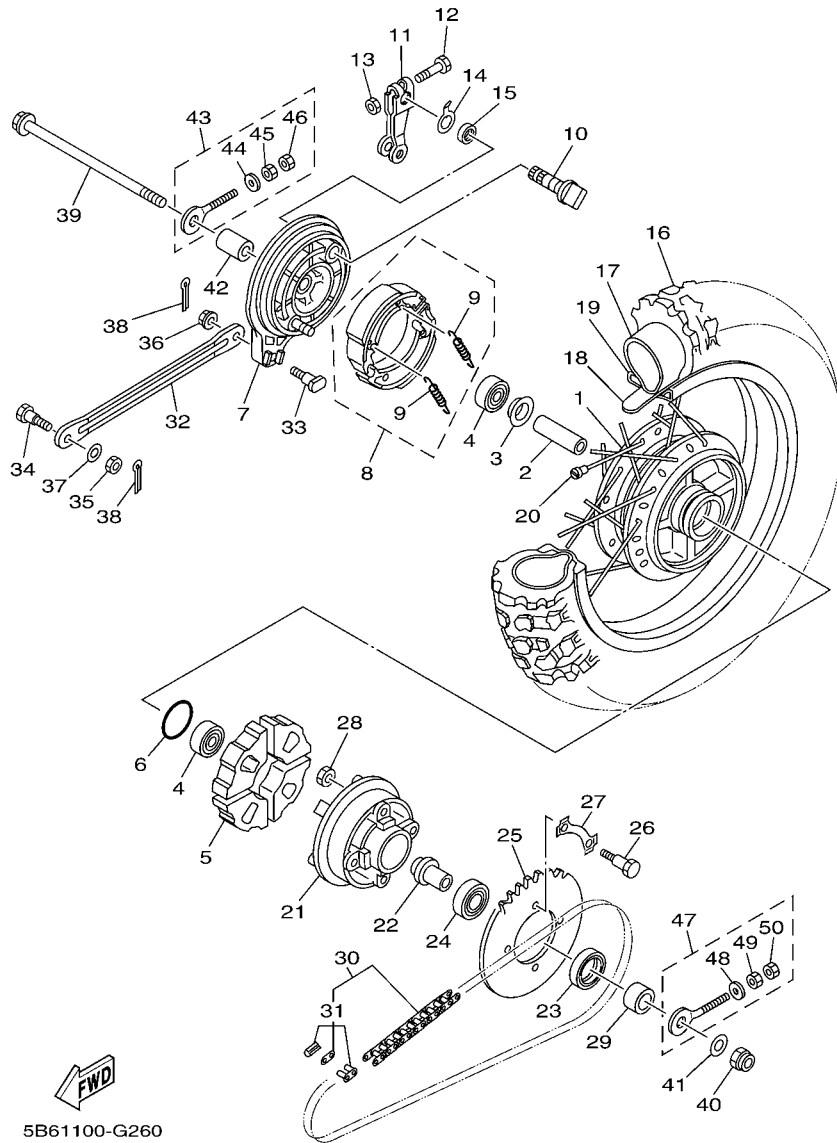

5B61100-G260

FIG. 26 REAR WHEEL

REF. NO.	PART NO.	DESCRIPTION	5B6J				REMARKS
28	90179-08168	NUT	4				
29	90387-207G3	COLLAR	1				
30	94580-52090	CHAIN (DID 420M 90LL)	1				
31	94661-66001	.JOINT, CHAIN (KMC420)	1				
32	4BC-25371-00	BAR, TENSION	1				
33	90109-08183	BOLT	1				
34	90109-08368	BOLT	1				
35	95307-08700	NUT	1				
36	95707-08500	NUT, FLANGE	1				
37	92902-08600	WASHER, PLATE	1				
38	91402-20012	PIN, COTTER	2				
39	5HN-25381-00	AXLE, WHEEL	1				
40	90185-12007	NUT, SELF-LOCKING	1				
41	90201-12045	WASHER, PLATE	1				
42	90387-12412	COLLAR	1				
43	3AC-2538G-10	PULLER, CHAIN	1				
44	90201-061A5	.WASHER, PLATE	1				
45	90170-06184	.NUT	1				
46	95307-06600	.NUT	1				
47	4GL-2538G-10	PULLER, CHAIN	1				
48	90201-061A5	.WASHER, PLATE	1				
49	90170-06184	.NUT	1				
50	95307-06600	.NUT	1				

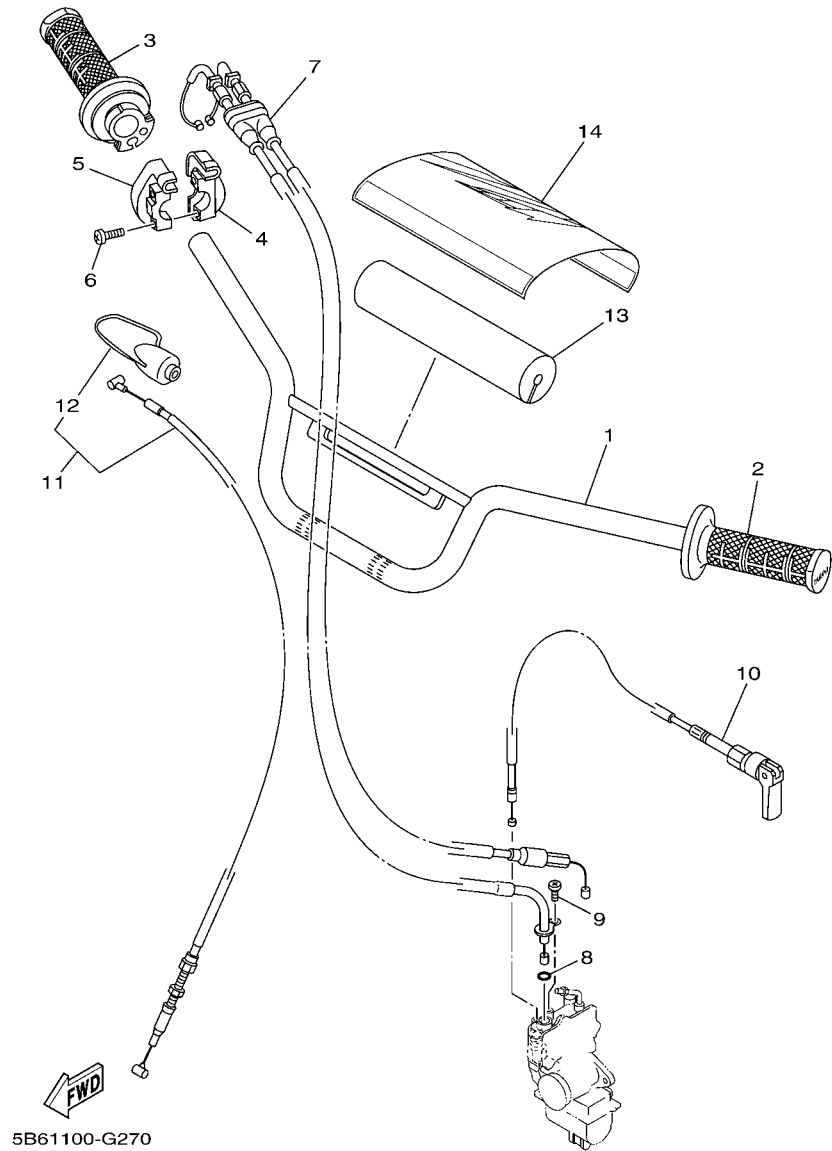
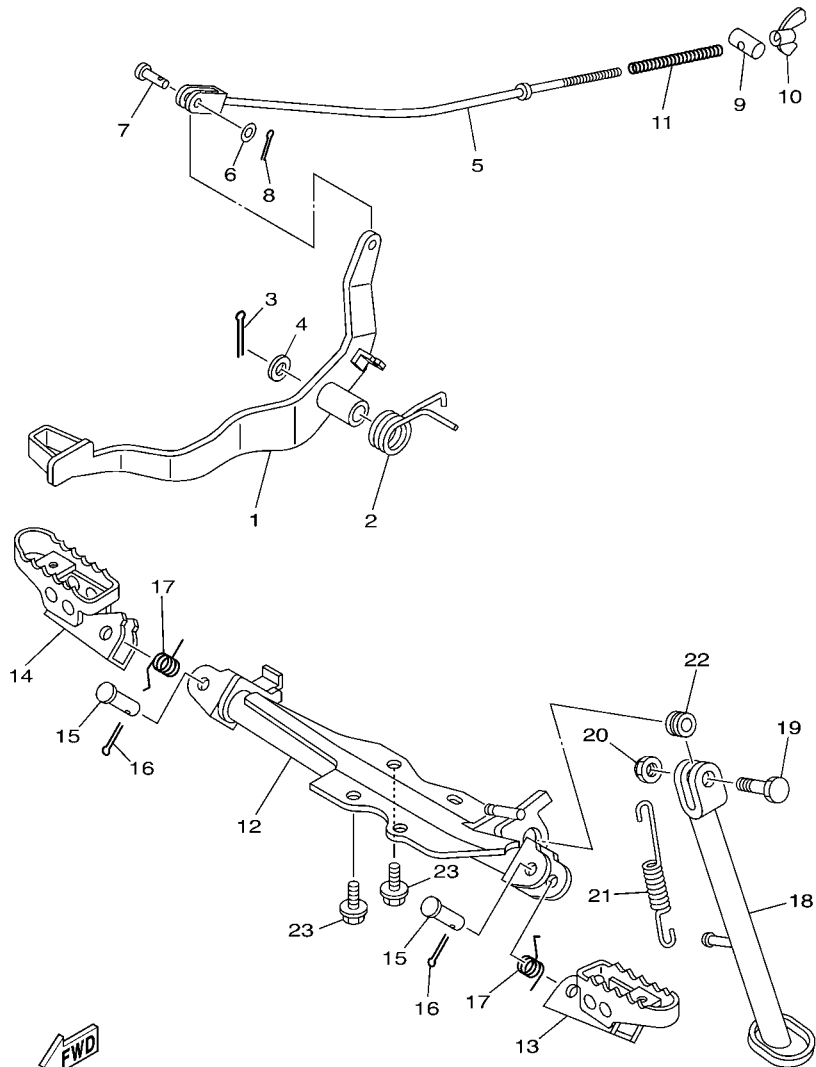

FIG. 27 STEERING HANDLE & CABLE

REF. NO.	PART NO.	DESCRIPTION	5B6J				REMARKS
1	5B6-26111-00	HANDLEBAR	1				
2	4GY-26241-00	GRIP	1				
3	5B6-26240-00	GRIP ASSY	1				
4	5BE-26281-01	CAP, GRIP UPPER	1				
5	5BE-26282-00	CAP, GRIP UNDER	1				
6	98507-05020	SCREW, PAN HEAD	2				
7	5B6-26302-00	THROTTLE CABLE ASSY	1				
8	93210-06667	O-RING	1				
9	98502-05008	SCREW, PAN HEAD	1				
10	5B6-26331-00	CABLE, STARTER 1	1				
11	5B6-26341-00	WIRE, BRAKE 1	1				
12	498-26372-00	.COVER, HANDLE LEVER 1	1				
13	5B6-26124-00	PROTECTOR, HANDLEBAR	1				
14	5B6-26143-00	COVER, HAND UPPER 1	1				



5B61100-G280

FIG. 28 STAND & FOOTREST

REF. NO.	PART NO.	DESCRIPTION	5B6J				REMARKS
1	5B6-27211-00	PEDAL, BRAKE	1				
2	90508-40016	SPRING, TORSION	1				
3	91402-20020	PIN, COTTER	1				
4	92902-12600	WASHER, PLATE	1				
5	5B6-27231-00	ROD, BRAKE	1				
6	92902-06200	WASHER	1				
7	90240-06076	PIN, CLEVIS	1				
8	91402-20012	PIN, COTTER	1				
9	90249-12008	PIN	1				
10	90175-06013	NUT, WING	1				
11	90501-10245	SPRING, COMPRESSION	1				
12	5B6-27411-00	FOOTREST 1	1				
13	3LD-27411-08	FOOTREST 1	1				
14	3LD-27421-08	FOOTREST 2	1				
15	90240-10002	PIN, CLEVIS	2				
16	91402-25015	PIN, COTTER	2				
17	90508-20007	SPRING, TORSION	2				
18	5B6-27311-00	STAND, SIDE	1				
19	90101-10003	BOLT	1				
20	90185-10037	NUT, SELF-LOCKING	1				
21	90506-26270	SPRING, TENSION	1				
22	90387-10003	COLLAR	1				
23	95812-08016	BOLT, FLANGE	4				

FIG. 29 GENERATOR

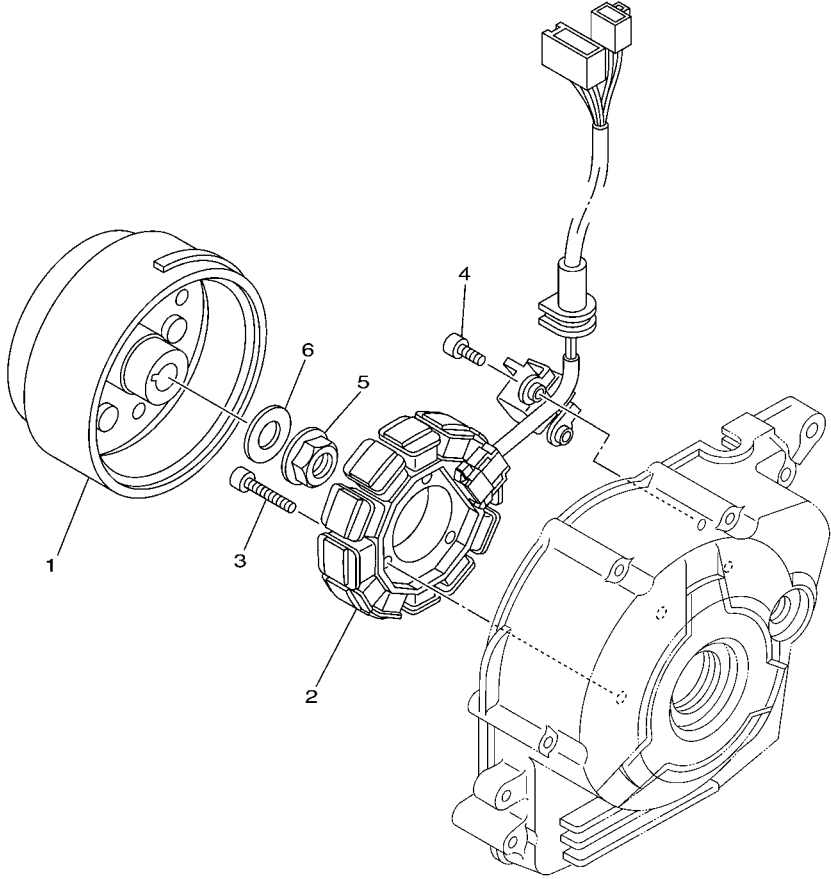

REF. NO.	PART NO.	DESCRIPTION	5B6J				REMARKS
1	5TP-H1450-00	ROTOR ASSY	1				
2	5B6-H1410-01	STATOR ASSY	1				
3	91317-06025	BOLT	3				
4	91317-06014	BOLT	2				
5	95707-12500	NUT, FLANGE	1				
6	90201-122H1	WASHER, PLATE	1				

 5TN1431-B320

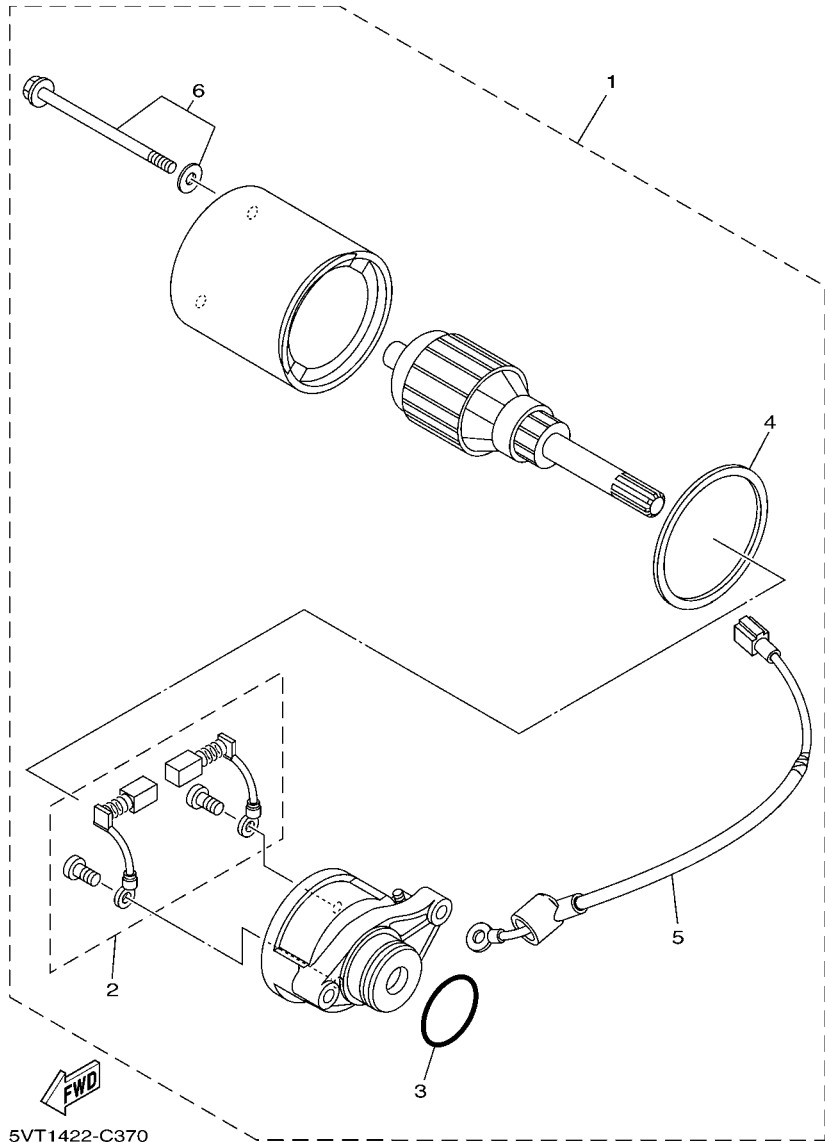

FIG. 30 STARTING MOTOR

REF. NO.	PART NO.	DESCRIPTION	5B6J				REMARKS
1	5B6-H1800-01	STARTING MOTOR ASSY	1				
2	5TP-H1801-00	.BRUSH SET	1				
3	5TP-H182L-00	.O-RING 1	1				
4	4ST-81861-00	.GASKET	1				
5	5B6-H183G-00	.CORD COMP.	1				
6	5TP-H1828-00	.SCREW 2	2				

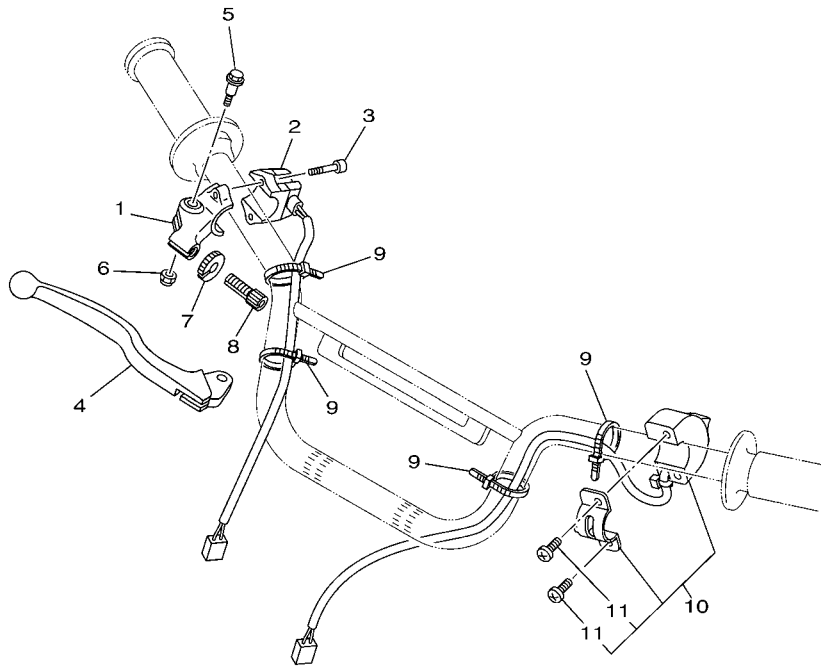

FIG. 31 HANDLE SWITCH & LEVER

REF. NO.	PART NO.	DESCRIPTION	SB6J				REMARKS
1	38V-82921-00	HOLDER, LEVER 2	1				
2	5B6-83976-11	SWITCH, HANDLE 1	1				
3	91317-05020	BOLT	2				
4	23X-83922-00	LEVER 2	1				
5	90109-06799	BOLT	1				
6	95607-06100	NUT, U	1				
7	90179-08148	NUT	1				
8	90123-08013	BOLT	1				
9	437-83936-01	BAND, SWITCH CORD	4				
10	5B6-83976-00	SWITCH, HANDLE 1	1				
11	98507-04014	.SCREW, PAN HEAD	2				

 5B61100-G310

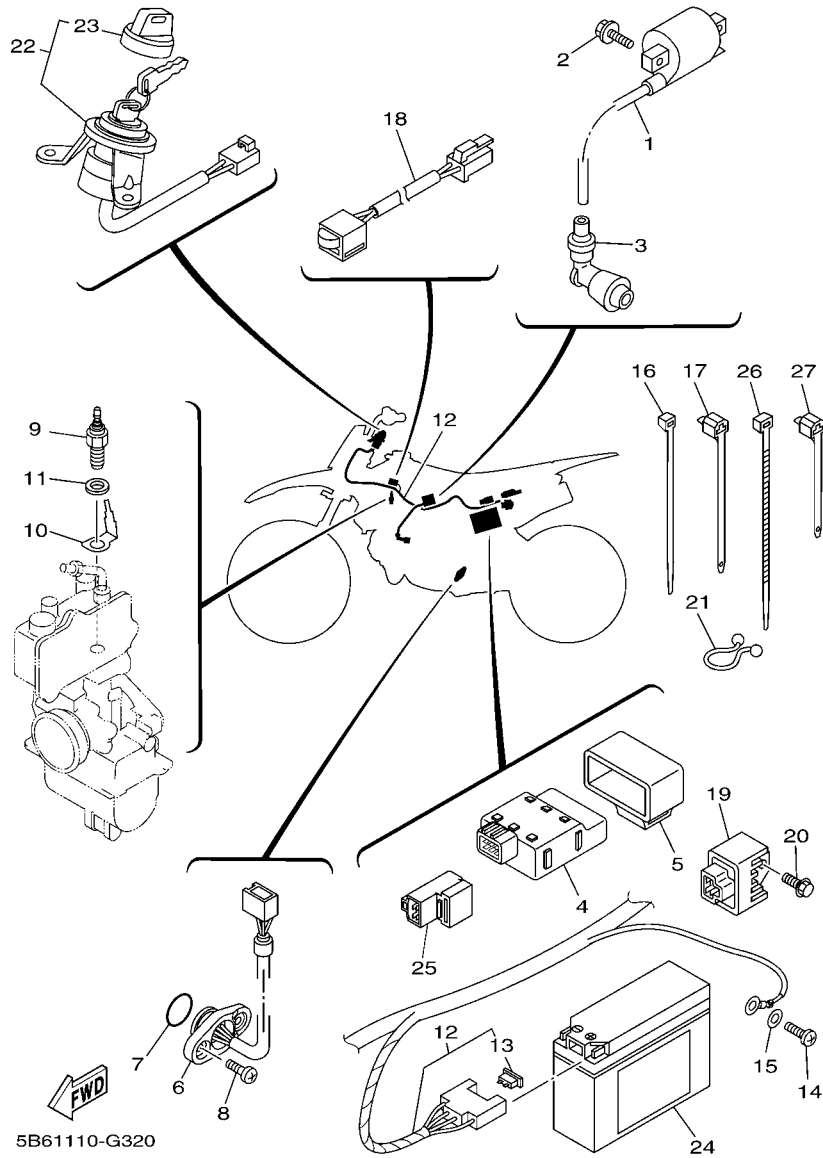

FIG. 32 ELECTRICAL 1

REF. NO.	PART NO.	DESCRIPTION	5B6J				REMARKS
1	4KJ-82310-10	IGNITION COIL ASSY	1				
2	95022-06016	BOLT, FLANGE	2				
3	4BP-82370-00	PLUG CAP ASSY	1				
4	5B6-85540-00	C.D.I. UNIT ASSY	1				
5	3MB-85546-00	BAND	1				
6	3S0-H2540-00	NEUTRAL SWITCH ASSY	1				
7	93210-228G1	O-RING	1				
8	98507-05010	SCREW, PAN HEAD	2				
9	5FU-83790-20	HEATER ASSY (30W)	1				
10	5FU-82103-00	TERMINAL 1	1				
11	90201-08016	WASHER, PLATE	1				
12	5B6-82590-01	WIRE HARNESS ASSY	1				
13	42X-82151-00	.FUSE (10A-BL)	1				
14	97880-06012	SCREW, PAN HEAD	1				
15	92990-06600	WASHER, PLATE	1				
16	90465-13152	CLAMP	2				
17	90465-13M24	CLAMP	1				
18	5FU-82560-50	THERMO SWITCH ASSY	1				
19	3LA-81960-01	RECTIFIER & REGULATOR ASSY	1				
20	95022-06012	BOLT, FLANGE	1				
21	90464-16039	CLAMP	1				
22	5B6-82510-00	MAIN SWITCH ASSY	1				
23	3HN-82579-00	.CAP, KEY	1				
24	4JS-82100-01	BATTERY ASSY (GS GT4B-5)	1				
25	29U-81950-93	RELAY ASSY	1				
26	1UA-82591-00	BAND	2				
27	90465-13M39	CLAMP	1				

NUMERICAL INDEX

PART NO.	REF. NO.	PART NO.	REF. NO.	PART NO.	REF. NO.	PART NO.	REF. NO.	PART NO.	REF. NO.	PART NO.	REF. NO.
4ST-11134-11	1 - 2	5B6-1479H-00	8 - 13	5B6-23141-00	22 - 5	5B6-24157-00	23 - 20	5B6-26341-00	27 - 11	3S0-E1636-00	2 - 9
5TN-12117-00	3 - 6	5HP-1479J-00	8 - 10		22 - 24	5B6-24158-00	23 - 21	498-26372-00	27 - 12	3S0-E1638-00	2 - 9
4TR-13474-01	6 - 20	5B6-1490J-00	7 - 5	5B6-23144-00	22 - 8	5B6-24173-00	23 - 30	5B6-27211-00	28 - 1	5TN-E1651-02	2 - 4
4GL-13595-01	6 - 2	256-14919-00	7 - 34		22 - 27	22W-24181-00	8 - 12	5B6-27231-00	28 - 5	5LM-E1681-00	2 - 2
5B6-14101-10	7 - 1	1A8-14953-00	7 - 30	5B6-23145-00	22 - 10	5B6-24181-00	23 - 10	5B6-27311-00	28 - 18	5TP-E2111-00	3 - 1
5DV-14103-00	7 - 13	5HN-14985-00	7 - 14		22 - 29	2X6-24183-00	23 - 12	5B6-27411-00	28 - 12	5TN-E2114-00	3 - 4
5HN-14104-00	7 - 9	3F7-14991-00	7 - 26	5B6-23146-00	22 - 11	5B6-24230-30	23 - 31	3LD-27411-08	28 - 13	3S0-E2118-00	3 - 5
5HN-1410A-00	7 - 15	5LW-14994-00	7 - 41		22 - 30	5B6-24250-30	23 - 32	3LD-27421-08	28 - 14	5ER-E2119-00	3 - 3
5B6-14112-25	7 - 17	5B6-15418-00	10 - 12	5B6-23147-00	22 - 7	5B6-24311-00	23 - 8	5HN-28100-00	17 - 11	5TP-E2121-00	3 - 2
1V3-14126-00	7 - 35	156-15618-01	11 - 12		22 - 26	1P6-24500-10	23 - 4	5B6-2839Y-00	18 - 9	5TN-E2126-00	3 - 7
5HN-14135-00	7 - 16	5B6-15620-00	11 - 11	5B6-23149-00	22 - 19	1P6-24512-10	23 - 5	4ST-81861-00	30 - 4	2P2-E2151-00	3 - 8
812-14137-00	7 - 29	5B6-18110-00	16 - 24		22 - 38	2FJ-24610-10	23 - 2	29U-81950-93	32 - 25	4ST-E2156-00	3 - 11
5KA-14141-13	7 - 4	132-18113-01	16 - 25	5B6-23151-00	22 - 13	5B6-2470F-00	24 - 2	3LA-81960-01	32 - 19	2P2-E2158-00	3 - 10
2MM-14142-12	7 - 6	4BA-18542-00	15 - 5		22 - 32	5B6-24710-00	24 - 1	4JS-82100-01	32 - 24	5VV-E2159-10	3 - 9
18A-14143-19	7 - 3	5B6-21110-00	17 - 1	3V2-23154-00	22 - 17	3R0-25104-00	25 - 20	5FU-82103-00	32 - 10	5TP-E2170-00	4 - 1
241-14147-00	7 - 18	3PT-2118K-A1	18 - 8		22 - 36	451-25111-00-35	25 - 1	34M-82131-00	19 - 16	5TP-E2176-00	4 - 6
5HN-14148-00	7 - 38	5B6-21279-00	17 - 9	2A6-23156-00	22 - 9	2E9-25116-00	25 - 6	42X-82151-00	32 - 13	2P2-E2210-00	4 - 13
5DW-14150-00	7 - 7	5B6-2137A-00	23 - 14		22 - 28	451-25118-00	25 - 26	4KJ-82310-10	32 - 1	3S0-E2213-00	4 - 14
4GL-14155-10	7 - 40	5B6-2137B-00	23 - 17	5B6-23157-00	22 - 12	5B6-25121-00-35	25 - 7	4BP-82370-00	32 - 3	2P2-E2231-00	4 - 10
522-14161-00	7 - 37	5B6-2139X-00	17 - 6		22 - 31	3L8-2513A-00	25 - 14	5B6-82510-00	32 - 22	2P2-E2241-00	4 - 11
353-14186-00	7 - 8	5B6-21511-00	18 - 1	5B6-23170-00	22 - 4	5B6-25151-00	25 - 10	5FU-82560-50	32 - 18	3S0-E3104-00	5 - 1
12R-14191-00	7 - 10	5XC-2153E-00	18 - 7		22 - 23	451-25155-00	25 - 11	3HN-82579-00	32 - 23	5TP-E3324-00	5 - 9
5YT-14193-00	7 - 36	5B6-21610-00	18 - 4	5B6-23173-00	22 - 14	5B6-25181-00	25 - 21	5B6-82590-01	32 - 12	5TP-E3325-00	5 - 2
4GL-14239-00	7 - 2	3RV-21668-A0	18 - 3		22 - 33	21W-25304-00	26 - 20	1UA-82591-00	32 - 26	5TP-E3329-00	5 - 4
4GL-14275-01	7 - 31	5B6-21710-00	19 - 1	5B6-2317E-00	21 - 16	21W-25311-00-35	26 - 1	38V-82921-00	31 - 1	4ST-E3411-00	5 - 8
4GL-14292-10	7 - 22	5B6-21720-00	19 - 6	1E7-23181-00	22 - 15	102-25315-00	26 - 3	5FU-83790-20	32 - 9	5TP-E3451-00	5 - 10
4GL-14293-00	7 - 24	5HN-2172W-00	19 - 12		22 - 34	5B6-25321-00-35	26 - 7	23X-83922-00	31 - 4	5B6-E3586-00	6 - 1
4GL-14348-00	7 - 19	5B6-21737-00	19 - 15	1L9-23183-00	22 - 16	3Y6-2533A-01	26 - 14	437-83936-01	31 - 9	5TP-E5113-00	10 - 11
5B6-14411-00	6 - 7	5HN-21746-00	19 - 11		22 - 35	3Y6-25351-00	26 - 10	5B6-83976-00	31 - 10	3S0-E5150-01	9 - 1
5B6-14412-00	6 - 8	5B6-21778-00	19 - 5	5B6-2319U-00	22 - 6	538-25355-00	26 - 11	5B6-83976-11	31 - 2	5TP-E5155-00	9 - 7
5Y1-14419-00	6 - 19	5B6-2177G-00	19 - 10		22 - 25	21W-25364-00	26 - 5	5B6-85540-00	32 - 4	5TP-E5316-00	9 - 16
5B6-14437-00	6 - 11	5B6-21826-10	23 - 3	5B6-23340-00	22 - 39	296-25366-01-35	26 - 21	3MB-85546-00	32 - 5	5B6-E5362-00	10 - 19
5XT-1443E-00	6 - 17	5B6-22110-00	20 - 1	451-23346-01	22 - 41	4BC-25371-00	26 - 32	5TP-E1111-30	1 - 1	5B6-E5371-00	9 - 3
5B6-14451-00	6 - 10	5B6-22123-00	20 - 2	5B6-2334G-00	22 - 42	5HN-25381-00	26 - 39	5TP-E1111F-00	4 - 4	5B6-E5411-00	10 - 1
5B6-14453-00	6 - 12	5B6-22151-00	20 - 3	5HP-23416-00	21 - 2	21W-25387-00	26 - 22	5B6-E1166-00	9 - 4	5B6-E5421-00	10 - 14
59V-14457-00	6 - 14	5B6-22199-00	20 - 7	3YF-23418-00	21 - 6	3AC-2538G-10	26 - 43	3S0-E1181-00	1 - 13	5B6-E5436-00	10 - 22
3LD-14462-00	6 - 13	5B6-22210-00	20 - 11	5B6-23435-00	21 - 7	4GL-2538G-10	26 - 47	4ST-E1185-00	1 - 5	3S0-E5451-00	10 - 2
5B6-14472-00	6 - 9	3M7-22216-00	20 - 12	1E6-23441-10-35	21 - 11	4AW-25412-00	26 - 27	4ST-E1186-00	1 - 8	4ST-E5461-11	10 - 15
4GL-14536-10	7 - 25	4AA-22259-80	20 - 13	5B6-23445-00	21 - 20	5A7-25435-01	26 - 25	4YS-E1198-00	5 - 7	2P2-E5512-00	12 - 1
4GL-14577-10	7 - 23	5B6-22311-00	20 - 10	5B6-23455-00	21 - 21	5B6-26111-00	27 - 1	5TP-E1310-01	1 - 16	5TP-E5524-00	12 - 3
5DV-14594-10	7 - 39	5B6-23102-00	22 - 1	5B6-23485-00	21 - 13	5B6-26124-00	27 - 13	4ST-E1351-02	1 - 18	5HV-E5580-00	12 - 5
3DM-14613-00	8 - 14	5B6-23103-00	22 - 20	5B6-23486-00	21 - 18	5B6-26143-00	27 - 14	5TP-E1422-00	2 - 5	5HV-E5583-00	12 - 6
5B6-14711-00	8 - 1	5B6-23110-00	22 - 2	5HN-23857-00	22 - 45	5B6-26240-00	27 - 3	5ER-E1445-00	2 - 6	5LM-E5641-00	11 - 2
5B6-14718-00	8 - 4		22 - 21	5B6-24110-00	23 - 1	4GY-26241-00	27 - 2	5TP-E1603-20	2 - 12	4WH-E5644-00	11 - 6
5B6-14728-00	8 - 5	5B6-23118-00	22 - 18	5B6-24116-00	23 - 27	5BE-26281-01	27 - 4	5TP-E1605-20	2 - 12		12 - 4
5B6-14738-00	8 - 6		22 - 37	5B6-2411J-00	23 - 9	5BE-26282-00	27 - 5	5TP-E1607-20	2 - 12	5TP-E5660-00	11 - 1
5HP-14758-00	8 - 9	5B6-23126-00	22 - 3	4EW-2412F-00	23 - 28	5B6-26302-00	27 - 7	3S0-E1631-00-A0	2 - 9	3S0-E5664-00	11 - 9
5B6-14780-00	8 - 2	5B6-23136-00	22 - 22	3HA-24141-00	17 - 10	5B6-26331-00	27 - 10	5LM-E1633-00	2 - 10	5LM-E5664-00	11 - 10

NUMERICAL INDEX

PART NO.	REF. NO.	PART NO.	REF. NO.	PART NO.	REF. NO.	PART NO.	REF. NO.	PART NO.	REF. NO.	PART NO.	REF. NO.
4WH-E5671-00	11 - 4	5B6-H183G-00	30 - 5	90201-08326	8 - 16	90464-15192	17 - 7	91402-20012	26 - 38	93306-203YR	14 - 8
5TP-E6135-00	13 - 24	3S0-H2540-00	32 - 6	90201-084K5	17 - 5	90464-16039	32 - 21		28 - 8	93306-204YC	14 - 20
2P2-E6150-10	13 - 13	5B6-W253A-00	25 - 8	90201-08609	1 - 10	90465-08230	1 - 19	91402-20020	28 - 3	93306-205YG	2 - 7
2P2-E6321-00	13 - 16	4BE-W253E-00	26 - 8	90201-106H5	20 - 16	90465-10833	9 - 12	91402-25015	28 - 16	93306-30111	26 - 4
2P2-E6324-00	13 - 15	5TP-WE140-20	2 - 1	90201-12019	13 - 10	90465-13152	23 - 11	91810-14809	1 - 14	93310-526Y6	2 - 3
5HV-E6346-00	9 - 2	90101-06278	26 - 12	90201-12045	26 - 41		32 - 16		9 - 8	93332-00079	22 - 44
2P2-E6350-00	13 - 21	90101-06291	25 - 12	90201-12166	14 - 7	90465-13M24	32 - 17		9 - 14	93340-210Y0	13 - 28
5B9-E6351-00	13 - 17	90101-08590	4 - 8	90201-122H1	29 - 6	90465-13M39	32 - 27		10 - 3	93340-212Y2	16 - 15
5LM-E6356-01	13 - 27	90101-08672	26 - 26	90201-126A7	16 - 18	90467-09006	23 - 13		10 - 16	93399-99949	21 - 1
5LM-E6357-00	13 - 26	90101-10003	28 - 19	90201-127F4	16 - 14	90467-11106	6 - 18	92017-06016	15 - 13	93410-20038	14 - 5
5B9-E6371-00	13 - 14	90105-05014	22 - 46	90201-127J6	20 - 5	90467-13064	9 - 5	92901-10100	22 - 40		14 - 12
5LM-E6512-00	13 - 6	90105-06064	23 - 15	90201-15700	14 - 17	90467-13808	9 - 6	92902-06200	28 - 6		14 - 23
5D9-E6586-00	13 - 7		23 - 18	90201-167P7	13 - 5	90467-22080	6 - 15	92902-08600	26 - 37	93440-10153	1 - 3
2P2-E6611-00	13 - 2	90105-08223	17 - 4	90201-178D3	16 - 11	90468-20196	20 - 17	92902-10200	25 - 22	93450-14088	2 - 11
2P2-E6620-00	13 - 3	90105-12026	20 - 4	90201-178J5	13 - 20	90468-23194	11 - 3	92902-12600	28 - 4	93604-10801	16 - 16
2P2-E6626-00	13 - 4	90109-06799	31 - 5	90201-20266	14 - 4	90480-01558	19 - 2	92903-10600	22 - 43	93604-12831	15 - 4
5TP-E7121-00	14 - 6	90109-08183	26 - 33		14 - 11		19 - 7	92907-04100	7 - 12	93606-10800	13 - 8
5TP-E7131-00	14 - 2	90109-08368	26 - 34	90201-220T0	21 - 10	90480-13428	21 - 15		7 - 21	93608-43157	12 - 2
5TP-E7141-00	14 - 3	90110-08097	8 - 17	90202-05193	23 - 6	90480-18290	23 - 23		7 - 28	93608-50149	16 - 8
5TP-E7211-00	14 - 15	90116-06804	1 - 4	90202-26142	21 - 4	90501-02639	12 - 8		7 - 33	93610-10174	12 - 7
5TP-E7231-00	14 - 14	90116-08807	9 - 15	90206-19027	11 - 5	90501-04800	13 - 9	92990-06600	32 - 15	93812-14814	14 - 22
5TP-E7241-00	14 - 13	90119-05827	13 - 19	90240-06076	28 - 7	90501-050F1	13 - 22	93101-10843	10 - 21	94125-141A6	25 - 16
5TP-E7402-00	14 - 10	90119-06051	18 - 2	90240-10002	28 - 15	90501-06022	15 - 6	93102-12891	16 - 6	94130-121A7	26 - 16
4ST-E7411-00	14 - 1	90123-08013	31 - 8	90240-10069	20 - 15	90501-06800	15 - 9	93102-15890	11 - 14	94225-14215	25 - 17
5TP-E8101-00	16 - 1	90149-06108	23 - 7	90240-10072	20 - 14	90501-10245	28 - 11	93102-20892	14 - 21	94227-12216	26 - 17
5TP-E8120-00	15 - 7	90149-06N01	15 - 3	90249-12008	28 - 9	90501-123A0	25 - 24	93104-10001	25 - 15	94325-14129	25 - 18
5TP-E8140-00	16 - 9	90155-06007	5 - 5	90269-07076	23 - 16	90501-125E9	16 - 17	93106-17006	25 - 4	94330-12130	26 - 18
5TP-E8152-10	16 - 5	90159-06056	6 - 21		23 - 19	90501-203G2	13 - 18	93106-30004	26 - 23	94414-14227	25 - 19
5TP-E8172-00	16 - 3	90170-06184	26 - 45	90280-03017	2 - 8	90506-14081	25 - 9	93109-14021	26 - 15	94416-12002	26 - 19
5LM-E8173-00	16 - 19		26 - 49	90340-12808	5 - 6	90506-15260	26 - 9	93210-06667	27 - 8	94568-B3086	4 - 9
5TP-E8179-00	16 - 2	90175-06013	28 - 10	90340-14812	10 - 7	90506-26270	28 - 21	93210-068F7	16 - 22	94580-52090	26 - 30
2P2-E817A-00	16 - 20	90176-08026	1 - 11	90340-32806	10 - 9	90508-20007	28 - 17	93210-10804	4 - 2	94661-66001	26 - 31
5TP-E8181-00	16 - 4	90179-08148	31 - 7	90387-05021	20 - 9	90508-26016	11 - 8	93210-148F8	10 - 8	94700-00880	1 - 12
2P2-E8185-00	15 - 2	90179-08168	26 - 28	90387-06153	18 - 6	90508-29007	16 - 7	93210-198F9	10 - 20	95022-06012	32 - 20
4YS-E8186-00	16 - 21	90179-08674	17 - 3	90387-06681	19 - 14	90508-40016	28 - 2	93210-228G1	32 - 7	95022-06016	32 - 2
5TP-E818A-00	15 - 12	90179-12659	13 - 11	90387-066J1	23 - 24	90560-10103	25 - 2	93210-25552	6 - 4	95022-06025	10 - 13
5TP-E8337-00	16 - 13	90179-14001	13 - 25	90387-10003	28 - 22	90560-12145	26 - 2	93210-258G2	6 - 3	95022-06040	9 - 11
5LM-E8511-00	15 - 10	90179-22412	21 - 9	90387-10744	25 - 25	90560-17384	13 - 12	93210-328G3	10 - 10		10 - 4
5LM-E8512-00	15 - 11	90179-25003	21 - 3	90387-12412	26 - 42	91317-05020	31 - 3	93210-41041	26 - 6		10 - 17
5TP-E8531-00	15 - 8	90179-25615	21 - 5	90387-1503D	14 - 16	91317-06012	4 - 5	93210-448G4	1 - 9	95022-06050	10 - 5
5B6-E8540-00	15 - 1	90183-04047	8 - 11	90387-16803	13 - 1		12 - 9	93210-568G8	1 - 17		10 - 18
5TP-E8699-00	16 - 10	90185-10037	28 - 20	90387-17004	13 - 23		22 - 48	93210-638G6	1 - 6	95022-06060	9 - 10
5B6-H1410-01	29 - 2	90185-12007	26 - 40	90387-207G3	26 - 29	91317-06014	29 - 4	93306-001Y7	14 - 9	95022-08035	21 - 8
5TP-H1450-00	29 - 1	90201-05017	8 - 7	90430-06014	4 - 15	91317-06016	4 - 12	93306-002X2	4 - 3		21 - 12
5B6-H1800-01	30 - 1	90201-061A5	26 - 44	90462-10801	9 - 13	91317-06018	4 - 16	93306-00416	26 - 24	95027-06010	8 - 3
5TP-H1801-00	30 - 2		26 - 48	90462-14055	22 - 47	91317-06025	6 - 6	93306-20004	25 - 3	95027-06090	1 - 15
5TP-H1828-00	30 - 6	90201-08016	32 - 11	90464-10190	17 - 8		29 - 3	93306-20009	25 - 5	9502L-06080	9 - 9
5TP-H182L-00	30 - 3	90201-08326	4 - 7	90464-13003	23 - 25	91317-06040	6 - 5	93306-202YW	14 - 19		10 - 6

NUMERICAL INDEX

PART NO.	REF. NO.	PART NO.	REF. NO.	PART NO.	REF. NO.	PART NO.	REF. NO.	PART NO.	REF. NO.
95307-06600	25 - 13								
	26 - 13								
	26 - 46								
	26 - 50								
95307-08700	26 - 35								
95602-10200	25 - 23								
95607-06100	31 - 6								
95617-12100	20 - 6								
95702-06500	16 - 23								
95707-06500	8 - 15								
95707-08500	26 - 36								
95707-12500	29 - 5								
95802-06010	23 - 22								
95802-06012	21 - 14								
	21 - 17								
	21 - 19								
95802-06014	18 - 5								
	19 - 3								
	19 - 8								
	19 - 13								
95802-06030	23 - 26								
95812-06016	19 - 4								
	19 - 9								
95812-08016	10 - 23								
	28 - 23								
95812-08120	17 - 2								
97017-06025	11 - 13								
97027-05014	20 - 8								
97027-06020	16 - 26								
97880-06012	32 - 14								
98502-05008	27 - 9								
98507-04010	7 - 27								
98507-04012	7 - 20								
98507-04014	7 - 11								
	31 - 11								
98507-04016	7 - 32								
98507-05010	32 - 8								
98507-05020	27 - 6								
98507-06016	1 - 7								
98702-06025	23 - 29								
98907-06025	6 - 16								
98980-06008	8 - 8								
99001-05600	5 - 3								
99009-12400	15 - 14								
99009-15400	14 - 18								
99009-17400	16 - 12								
99009-19400	11 - 7								