

**PARTS  
CATALOGUE  
CATALOGO  
DE REPUESTOS**

**YW125X** (2DU4) COLOMBIA

---



1P2DU-261S1

( )

YW125X  
CATALOGO DE REPUESTOS  
©2015 por Yamaha Motor Co., Ltd.  
1ª edición, marzo 2015  
Todos los derechos reservados.  
Toda reproducción o uso no autorizado  
sin el consentimiento escrito de  
Yamaha Motor Co., Ltd.  
quedan expresamente prohibidos  
Impreso en Japón.

YW125X  
PARTS CATALOGUE  
©2015 by Yamaha Motor Co., Ltd.  
1st edition, March 2015  
All rights reserved.  
Any reprinting or unauthorized use  
without the written permission of  
Yamaha Motor Co., Ltd.  
is expressly prohibited.  
Printed in Japan.

# PROLOGO

Este catálogo de repuestos corresponde a las piezas para el o los modelos que figuran en la página de portada. Al formular el pedido de repuestos, se ruega citar este catálogo y especificar correctamente el número y el nombre de las piezas.

1. Las modificaciones y agregados que se hayan realizado después de la edición de este Catálogo de Repuestos, serán anunciados en las Informaciones de Recambios. Es recomendable que se hagan las correcciones necesarias en el Catálogo de Repuestos de acuerdo con las Informaciones de Recambios.

2. Abreviaciones

En este. Catálogo de Repuestos se emplean las siguientes abreviaciones.

“UR” Usar el número de partes especificado

“UN” Usar la cantidad necesaria

“AP” Piezas sustitutivas

“LM” Fabricación local (Hay que pedir los repuestos en las cercanías)

“F#” N° de bastidor (N° aplicable a la máquina)

“O/S” Sobredimensionado

3. La cantidad de componentes para el montaje

- Los componentes, suministrados como conjunto, se describen con un punto (.) que precede al nombre del parte como se indica a continuación.
- La numeración que aparece a la derecha de cada descripción indica la cantidad de partes por cada unidad de conjunto.

CODIGO N°	DESCRIPCION	CANT.	OBSERVACIONES
2F5-83310-60	ENSAMBLAJE DE LA LUZ	2	
115-83311-60	.BOMBILLA (6V-18W)	1	

4. Los colores de los componentes se indican como sigue en la columna de “OBSERVACIONES”.

CODIGO N°	DESCRIPCION	CANT.	OBSERVACIONES
2N4-24110-00-X5	COMP. DEL TANQUE	2	MXR
3J1-24240-10	.GRAFICO, DEL TANQUE	1	PARA MXR

5. Debe tenerse en cuenta que las ilustraciones sirven como guía para la búsqueda de los números de partes y no deben usarse para el montaje. Durante el montaje, se recomienda usar el manual de taller correspondiente.

6. EL asterisco (\*) antes del número de referencia indica los elementos modificados después de la primera edición.

# FOREWORD

This Parts Catalogue is related to the parts for the model(s) on the cover page. When you are ordering replacement parts, please refer to this Parts Catalogue and quote both part numbers and part names correctly.

1. Modifications or additions which have been made after the issue of the Parts Catalogue will be announced in the Parts News.

It is advisable that you make the necessary corrections to the Parts Catalogue according to the Parts News.

2. Abbreviations

The following abbreviations are used in this Parts Catalogue.

“UR” Use specified parts number.

“UN” Use as many as needed.

“AP” Alternate Parts

“LM” Locally Made (Parts need to be ordered locally)

“F#” Frame No. (Applicable machine No.)

“O/S” Over Size

3. The number of components for assembly

- Parts, which are to be supplied in an assembly, are listed with a dot (.) in front of the part name as shown below.
- The numeral appearing to the right of each component part indicates the quantity of parts for each assembly unit.

PART NO.	DESCRIPTION	Q'TY	REMARKS
2F5-83310-60	FRONT FLASHER LIGHT ASSY	2	
115-83311-60	.BULB (6V-18W)	1	

4. Applicable colours of graphics are represented in the “REMARKS” as shown below.

PART NO.	DESCRIPTION	Q'TY	REMARKS
2N4-24110-00-X5	FUEL TANK COMP.	2	MXR
3J1-24240-10	.GRAPHIC, FUEL TANK	1	FOR MXR

5. Note that the illustrations for reference in finding parts numbers are not to be used for assembling. When assembling, please use the applicable service manual.

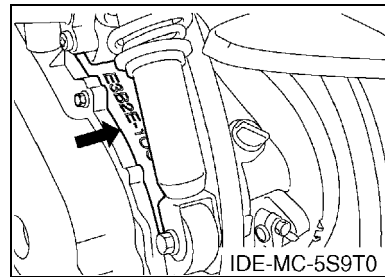
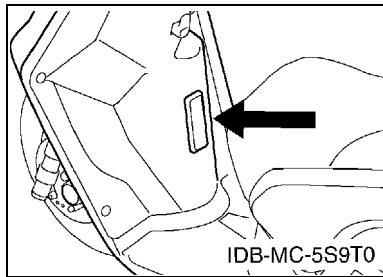
6. The asterisk (\*) before a reference number indicates modified items after the first edition.

# PROLOGO

## 7. Números de serie

Nº de Serie del bastidor

Nº de Serie del motor



## 8. Códigos de color aplicables (El símbolo (\*) muestra el color de modelo.)

Abreviatura	Nombre de color	Código de color
DNMM	DARK GRAY METALLIC M	1265
MDS	MIDNIGHT SILVER	007M
MT1(*)	MAT TITAN 1	0620
NMM	GRAY METALLIC M	1373
PRM2(*)	PURPLISH RED METALLIC 2	0793
SL	SILVER	0035
SMX(*)	BLACK METALLIC X	0903
VOS2(*)	VIVID ORANGE SOLID 2	0921
VPBM2	VIVID PURPLISH BLUE METALLIC 2	0631
WM1(*)	WHITE METALLIC 1	0233
YB	YAMAHA BLACK	0033

## 9. Nº de serie inicial aplicable

Nº de Serie del bastidor

Nº de serie	Nombre de la columna de cantidades	Código de Modelo

Nº de Serie del motor

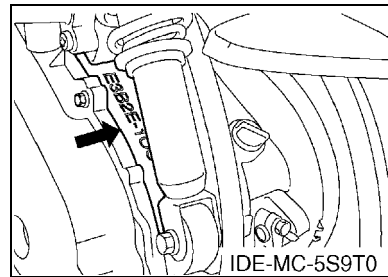
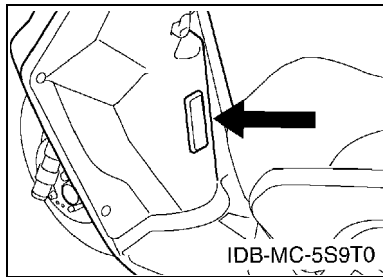
Nº de serie	Nombre de la columna de cantidades	Código de Modelo

# FOREWORD

## 7. Applicable Serial No.

Frame Serial No.

Engine Serial No.



## 8. Applicable Colour Code (The (\*) mark shows Model colour.)

Abbreviation	Colour Name	Colour Code
DNMM	DARK GRAY METALLIC M	1265
MDS	MIDNIGHT SILVER	007M
MT1(*)	MAT TITAN 1	0620
NMM	GRAY METALLIC M	1373
PRM2(*)	PURPLISH RED METALLIC 2	0793
SL	SILVER	0035
SMX(*)	BLACK METALLIC X	0903
VOS2(*)	VIVID ORANGE SOLID 2	0921
VPBM2	VIVID PURPLISH BLUE METALLIC 2	0631
WM1(*)	WHITE METALLIC 1	0233
YB	YAMAHA BLACK	0033

## 9. Applicable Starting Serial No.

Frame Serial No.

Serial No.	Name Of Q'ty Column	Model Code

Engine Serial No.

Serial No.	Name Of Q'ty Column	Model Code

# CONTENIDO

## MOTOR

CILINDRO .....	1
CIGUENAL & PISTON .....	3
VALVULA .....	4
CUBIERTA DE AIRE & VENTILADOR .....	5
BOMBA DE ACEITE .....	6
ADMISION .....	7
CARBURADOR .....	8
DESCARGA .....	10
CARTER .....	11
ARRANQUE .....	13
EMBRAGUE .....	14
TRANSMISION .....	16

## SHASIS

CUADRO .....	17
GUARDABARRO DELANTERO .....	19
CUBIERTA LATERAL .....	20
BRAZO TRASERO & SUSPENSION .....	22
HORQUILLA DELANTERA .....	23
DEPOSITO DE COMBUSTIBLE .....	25
ASIENTO .....	27
RUEDA DELANTERA .....	28
CALIBRE FRENO DELANTERA .....	29
RUEDA TRASERA .....	30
MANILLAR & CABLE .....	31
CILINDRO MAESTRO DELANTERO .....	32
SOPORTE & APOYAPIE .....	33
PATA PROTEGIDA .....	34
BOVEDA 1 .....	36
GENERADOR .....	37
MOTOR DE ARRANQUE .....	38
LUZ DE DESTELLADOR .....	39
MEDIDOR .....	40
FARO DELANTERO .....	41
LUZ DE COLA .....	42
INTERRUPTOR DE MANILLAR&PALANC .....	43
EQUIPO ELECTRICO 1 .....	44

## INDICE

INDICE NUMERICO .....	46
-----------------------	----

# CONTENTS

## ENGINE

CYLINDER .....	1
CRANKSHAFT & PISTON .....	3
VALVE .....	4
AIR SHROUD & FAN .....	5
OIL PUMP .....	6
INTAKE .....	7
CARBURETOR .....	8
EXHAUST .....	10
CRANKCASE .....	11
STARTER .....	13
CLUTCH .....	14
TRANSMISSION .....	16

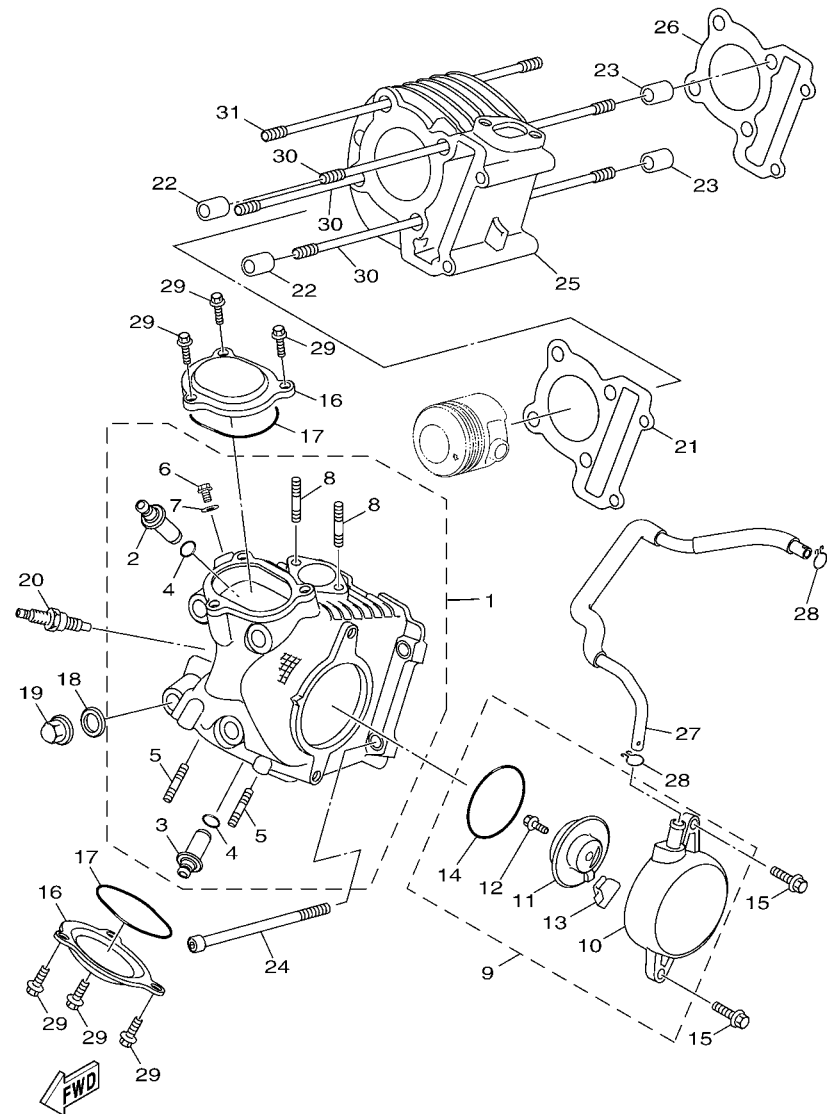
## CHASSIS

FRAME .....	17
FRONT FENDER .....	19
SIDE COVER .....	20
REAR ARM & SUSPENSION .....	22
FRONT FORK .....	23
FUEL TANK .....	25
SEAT .....	27
FRONT WHEEL .....	28
FRONT BRAKE CALIPER .....	29
REAR WHEEL .....	30
STEERING HANDLE & CABLE .....	31
FRONT MASTER CYLINDER .....	32
STAND & FOOTREST .....	33
LEG SHIELD .....	34
COWLING 1 .....	36
GENERATOR .....	37
STARTING MOTOR .....	38
FLASHER LIGHT .....	39
METER .....	40
HEADLIGHT .....	41
TAILLIGHT .....	42
HANDLE SWITCH & LEVER .....	43
ELECTRICAL 1 .....	44

## INDEX

NUMERICAL INDEX .....	46
-----------------------	----





58P4261-M010

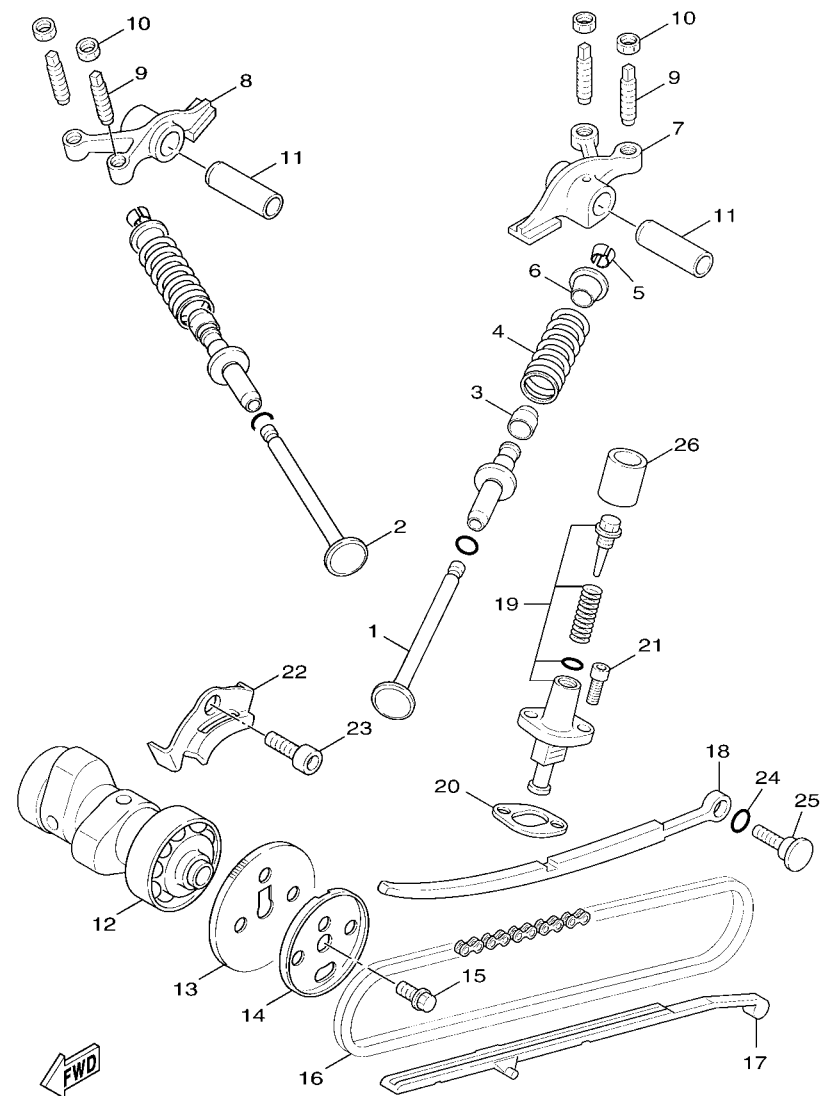
FIG. 1 CILINDRO

CYLINDER

REF. Nº	CODIGO Nº PART NO.	DESCRIPCION DESCRIPTION	2DU4				OBSERVACIONES REMARKS
1	24P-E1102-00	CULATA DE CILINDRO COMPLETA CYLINDER HEAD ASSY	1				
2	5ML-11133-10	.GUIA DE VALVULA 1 .GUIDE, VALVE 1	2				
3	5ML-11134-10	.GUIA DE VALVULA 2 .GUIDE, VALVE 2	2				
4	93210-09802	.ANILLO O .O-RING	4				
5	90116-08806	.ESPARRAGO .BOLT, STUD	2				
6	90153-06803	.TORNILLO HEXAGONAL .SCREW, HEXAGON	1				
7	90430-06014	.JUNTA .GASKET	1				
8	95617-06625	.PERNO DE PUNTAL .BOLT, STUD	2				
9	5ML-E1160-00	RESPIRADERO COMPLETO BREATHER ASSY	1				
10	5ML-E1185-00	.CUBIERTA CULATA CIL.LAT.3 .COVER, CYLINDER HEAD SIDE 3	1				
11	5ML-E1165-00	.PLACA RESPIRADERO .PLATE, BREATHER	1				
12	97517-06512	.PERNO CON ARANDELA .BOLT, WITH WASHER	1				
13	4CW-E1155-00	.SELLO LABERINTO .SEAL, LABYRINTH	1				
14	93210-71803	.ANILLO O .O-RING	1				
15	95027-06020	PERNO, DE BRIDA BOLT, FLANGE	2				
16	5ML-E1186-00	CUBIERTA CULATA CIL.LAT.2 COVER, CYLINDER HEAD SIDE 2	2				
17	93210-54008	ANILLO O O-RING	2				
18	90201-08609	ARANDELA PLANA WASHER, PLATE	4				
19	90176-08816	TUERCA CORONA NUT, CROWN	4				
20	94700-00881	BUJIA (DENSO U22ESR-N) PLUG, SPARK (DENSO U22ESR-N)	1				
21	5ML-E1181-00	JUNTA, DE CULATA 1 GASKET, CYLINDER HEAD 1	1				
22	91810-14807	PASADOR DE CLAVIJA PIN, DOWEL	2				
23	91810-14807	PASADOR DE CLAVIJA PIN, DOWEL	2				
24	91317-06100	PERNO BOLT	2				
25	5ML-E1311-20	CILINDRO 1 CYLINDER 1	1				
26	5ML-E1351-20	JUNTA, DE CILINDRO GASKET, CYLINDER	1				
27	58P-E4987-00	TUBO HOSE	1				





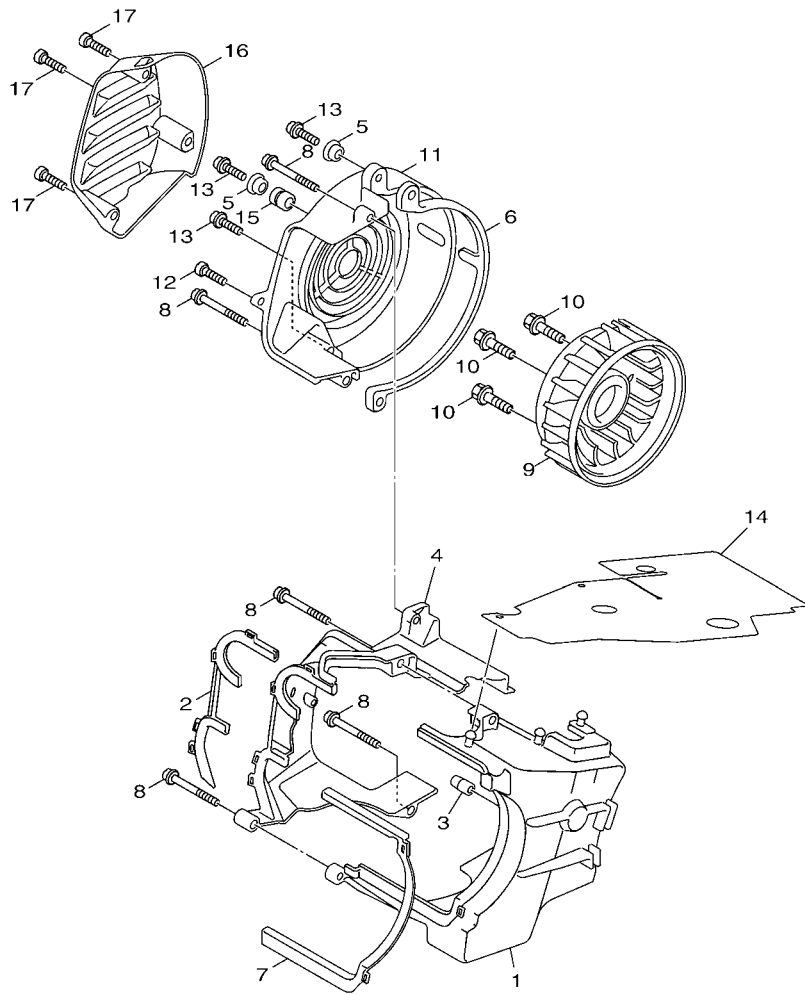


24S1210-H030

FIG. 3 VALVULA

VALVE

REF. Nº	CODIGO Nº PART NO.	DESCRIPCION DESCRIPTION	2DU4				OBSERVACIONES REMARKS
1	4C6-E2111-00	VALVULA DE ADMISION VALVE, INTAKE	2				
2	4C6-E2121-00	VALVULA DE ESCAPE VALVE, EXHAUST	2				
3	5ML-E2119-00	SELLO DE ACEITE VALVULA SEAL, VALVE STEM	4				
4	5ML-12113-00	RESORTE VALVULA INTERNA SPRING, VALVE INNER	4				
5	5WG-E2118-00	SEGURO DE VALVULA LOCK, VALVE SPRING RETAINER	8				
6	4C6-E2117-00	RETEN RESORTE DE VALVULA RETAINER, VALVE SPRING	4				
7	1P3-E2151-00	BRAZO DE BALANCIN DE VALVULA ARM, VALVE ROCKER	1				
8	1P3-E2161-00	BRAZO DE BALANCIN DE VALVULA ARM, VALVE ROCKER 2	1				
9	5FM-E2159-00	TORNILLO DE AJUSTE DE VALVULA SCREW, VALVE ADJUSTING	4				
10	90170-05800	TUERCA NUT	4				
11	5HK-E2156-00	EJE DE BALANCIN SHAFT, ROCKER 2	2				
12	5S9-E2170-01	ARBOL DE LEVAS COMPLETO 1 CAMSHAFT ASSY 1	1				
13	5LW-E2176-00	CATALINA DE CADENA SPROCKET, CAM CHAIN	1				
14	5ML-E1145-00	PLACA RESPIRADERO 2 PLATE, BREATHER 2	1				
15	95817-08016	TORNILLO BOLT, FLANGE	1				
16	94568-75094	CADENA CHAIN	1				
17	5ML-E2231-00	TOPE DE GUIA 1 GUIDE, STOPPER 1	1				
18	5ML-E2241-00	TOPE DE GUIA 2 GUIDE, STOPPER 2	1				
19	5ML-E2210-00	TENSOR CADENA DE LEVA TENSIONER ASSY, CAM CHAIN	1				
20	4DH-E2213-01	EMPAQUE DE CAJA TENSOR GASKET, TENSIONER CASE	1				
21	91317-06016	PERNO BOLT	2				
22	5ML-E111F-00	PLACA PLATE	1				
23	91317-06012	PERNO BOLT	1				
24	93210-15862	ANILLO O O-RING	1				
25	3B3-E2157-00	PERNO BOLT	1				
26	4CW-E2232-00	AMORTIGUADOR DAMPER	1				

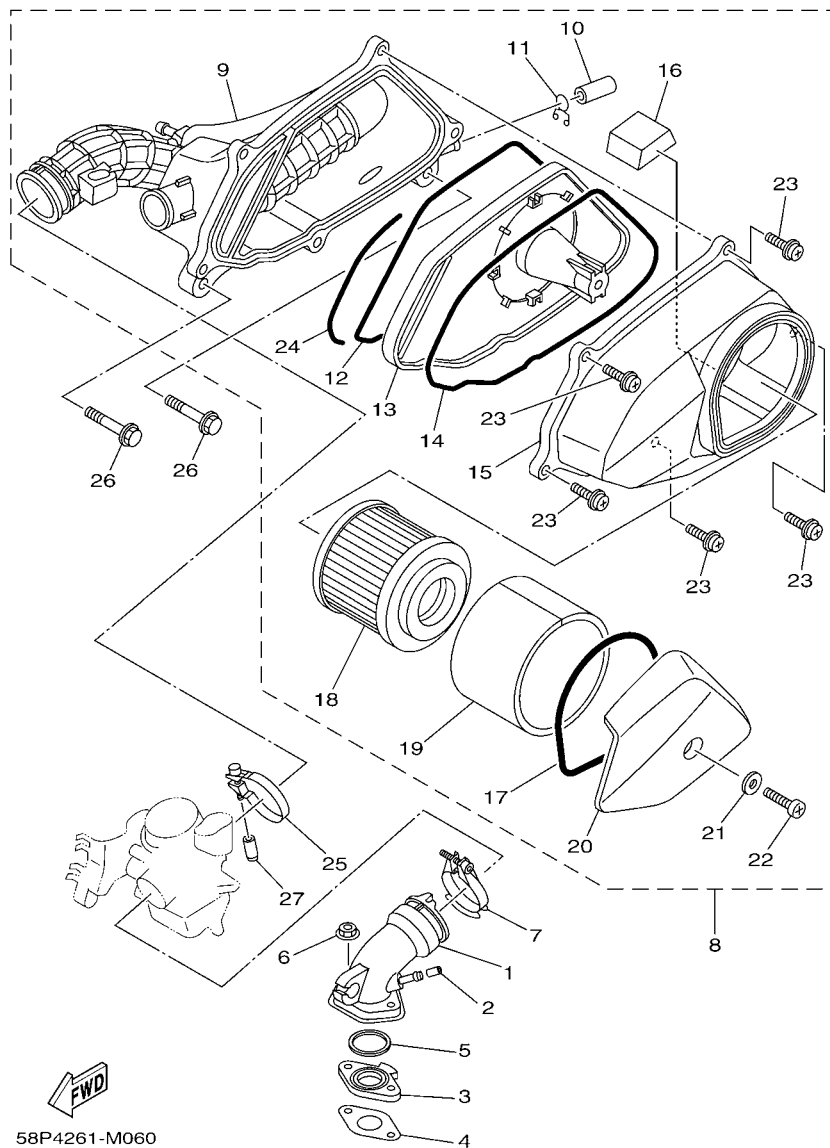


58P4261-M040

FIG. 4 CUBIERTA DE AIRE & VENTILADOR AIR SHROUD & FAN

REF. N°	CODIGO N° PART NO.	DESCRIPCION DESCRIPTION	2DU4				OBSERVACIONES REMARKS
1	5ML-E2651-00	CUBIERTA DE PASO DE AIRE 1 AIR SHROUD, CYLINDER 1	1				
2	5ML-E2668-00	AMORTIGUADOR DE CUBIERTA 3 DAMPER, AIR SHROUD 3	1				
3	3KW-E3569-00	TAPON CIEGO PLUG, BLIND	1				
4	5ML-E2652-00	CUBIERTA DE PASO DE AIRE 2 AIR SHROUD, CYLINDER 2	1				
5	90387-068F9	ESPACIADOR COLLAR	3				
6	5ML-E2658-00	AMORTIGUADOR DE CUBIERTA 1 DAMPER, AIR SHROUD 1	1				
7	5ML-E2659-00	AMORTIGUADOR DE CUBIERTA 2 DAMPER, AIR SHROUD 2	1				
8	97707-60530	TORNILLO ROSCA HEMBRA SCREW, TAPPING	5				
9	5TY-E2611-00	VENTILADOR FAN	1				
10	90119-06857	TORNILLO CON ARANDELA BOLT, WITH WASHER	4				
11	5ML-E2653-01	CUBIERTA DE PASO DE AIRE 3 AIR SHROUD, CYLINDER 3	1				
12	97707-60516	TORNILLO ROSCA HEMBRA SCREW, TAPPING	1				
13	98980-06020	TORNILLO DE LIGAR SCREW, BIND	3				
14	58P-E2682-00	PROTECTOR PROTECTOR, HEAT	1				
15	90480-12497	TAPON GROMMET	1				
16	5S9-E262H-00	GUIA 1 GUIDE 1	1				
17	97707-60520	TORNILLO ROSCA HEMBRA SCREW, TAPPING	3				





58P4261-M060

FIG. 6 ADMISION

INTAKE

REF. N°	CODIGO N° PART NO.	DESCRIPCION DESCRIPTION	2DU4				OBSERVACIONES REMARKS
1	24P-E3585-01	MULTIPLE MANIFOLD	1				
2	24P-E4251-00	NIPLE NIPPLE	1				
3	5ML-E3595-00	TOBERA JOINT	1				
4	5ML-E3556-20	EMPAQUE GASKET, MANIFOLD	1				
5	93210-27800	ANILLO O O-RING	1				
6	95707-06500	TUERCA DE BRIDA NUT, FLANGE	2				
7	5ML-E3474-00	BANDA BAND	1				
8	58P-E4410-00	FILTRO DE AIRE COMPLETO AIR CLEANER ASSY.	1				
9	58P-WE441-00	.CAJA COMPLETO FILTRO DE AIRE .AIR CLEANER CASE COMP.	1				
10	58P-E443E-00	.TUBO, DRENAJE .PIPE, DRAIN	1				
11	90467-12052	.PRESILLA .CLIP	1				
12	58P-E4462-00	.SELLO .SEAL	1				
13	58P-E4484-00	.PLACA .PLATE, CLEANER CASE FITTING	1				
14	58P-E4467-00	.SELLO .SEAL	1				
15	58P-WE442-00	.TAPA CAJA DEL FILTRO 1 .CAP CLEANER CASE 1	1				
16	58P-E442G-00	.AMORTIGUADOR 3 .DAMPER 3	1				
17	58P-E4452-00	.SELLO .SEAL	1				
18	5HK-E4451-00	.ELEMENTO DEL FILTRO DEL AIRE .ELEMENT, AIR CLEANER	1				
19	58P-E4461-00	.ELEMENTO COMPLETO .ELEMENT, AIR CLEANER 2	1				
20	58P-E4422-00	.TAPA CAJA DE FILTRO 2 .CAP, CLEANER CASE 2	1				
21	90201-064H0	.ARANDELA PLANA .WASHER, PLATE	1				
22	90154-06827	.TORNILLO DE LIGAR .SCREW, BINDING	1				
23	97607-06220	.TORNILLO CAB CON PLANA C/ARAN .SCREW, WITH WASHER	5				
24	58P-E446R-00	.SELLO .SEAL	1				
25	5ML-E3575-00	BANDA BAND	1				
26	95807-06030	TORNILLO BOLT, FLANGE	2				
27	1CD-E4169-00	FUNDA CAP	1				

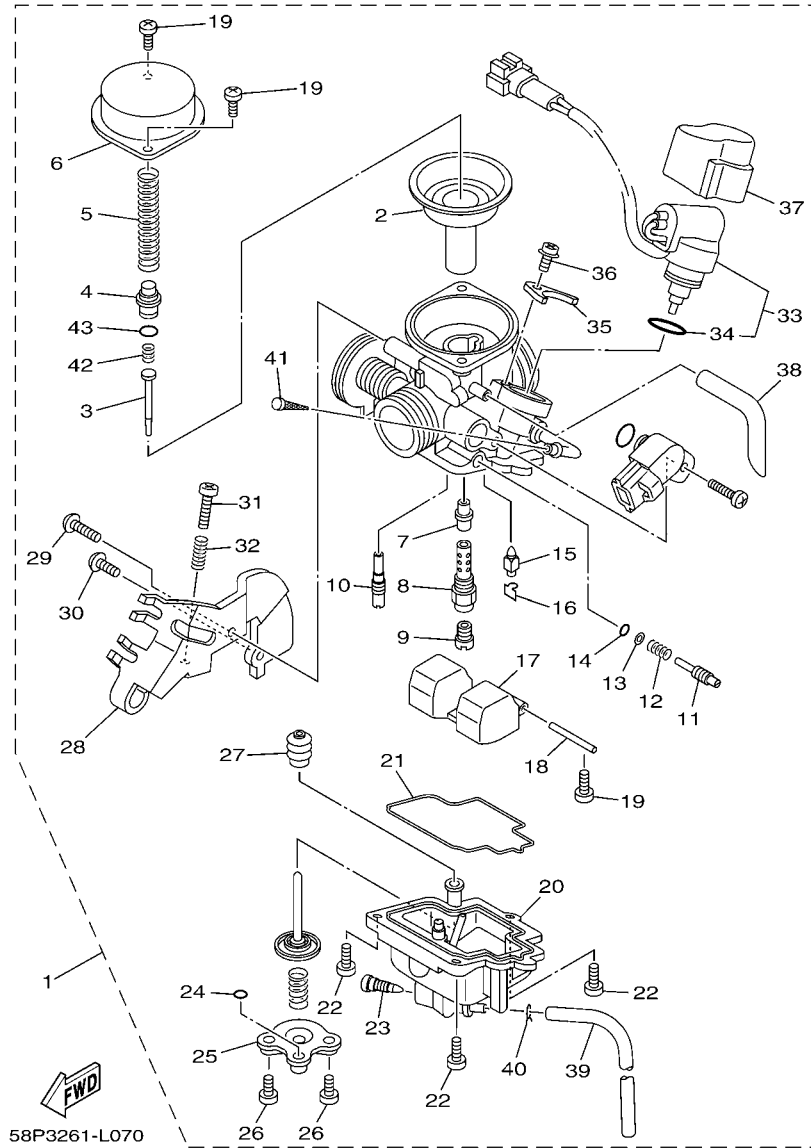


FIG. 7 CARBURADOR

CARBURETOR

REF. Nº	CODIGO Nº PART NO.	DESCRIPCION DESCRIPTION	2DU4				OBSERVACIONES REMARKS
1	24P-E4901-20	CARBURADOR COMPLETO 1 CARBURETOR ASSY 1	1				
2	24P-E4940-00	.DIAFRAGMA COMPLETO .DIAPHRAGM ASSY	1				
3	24P-E4916-20	.AGUJA DE SURTIDOR .JET NEEDLE COMP.	1				
4	5TY-E4936-00	.ASIENTO DE RESORTE .SEAT, SPRING	1				
5	24P-E4933-00	.RESORTE DE DIAFRAGMA .SPRING, DIAPHRAGM	1				
6	5TY-E4958-00	.CUBIERTA DE DIAFRAGMA .COVER, DIAPHRAGM	1				
7	5TY-E4947-00	.INYECTOR DE AGUJA .JET, NEEDLE	1				
8	24P-E414G-00	.AEUJA DE CARB. .PIPE, MAIN BLEED	1				
9	24P-E4943-78	.INYECTOR PRINCIPAL .JET, MAIN	1				
10	24P-E4948-00	.INYECTOR .JET	1				
11	24P-E4211-00	.TORNILLO DE AJUSTE DE PILOTO .SCREW, PILOT ADJUSTING	1				
12	4JH-14160-00	.BOBINA .COIL, SPRING	1				
13	3TJ-14952-40	.ARANDELA .WASHER	1				
14	3TJ-14562-40	.ANILLO O .O-RING	1				
15	5ML-E4590-00	.VALVULA DE AGUJA COMPLETA .NEEDLE VALVE ASSY	1				
16	663-14159-00	.PRESILLA .CLIP	1				
17	5TY-E4985-00	.BOIA .FLOAT	1				
18	5ML-E4386-00	.PASADOR DE BOIA .PIN, FLOAT	1				
19	688-14592-00	.TORNILLO .SCREW	3				
20	24P-E4980-00	.CUERPO CAMARA DE BOIA .BODY, FLOAT CHAMBER	1				
21	5TY-E4984-00	.EMPAQUE CAMARA DE BOIA .GASKET, FLOAT CHAMBER	1				
22	98502-04012	.TORNILLO .SCREW, PAN HEAD	3				
23	3TJ-14191-40	.TORNILLO, DE DRENAJE .PLUG, DRAIN	1				
24	3TJ-14536-40	.EMPAQUE .GASKET	1				
25	5ML-E4958-00	.CUBIERTA DE DIAFRAGMA .COVER, DIAPHRAGM	1				
26	5ML-E4592-00	.TORNILLO .SCREW	2				
27	5ML-E4969-00	.TAPA .CAP	1				



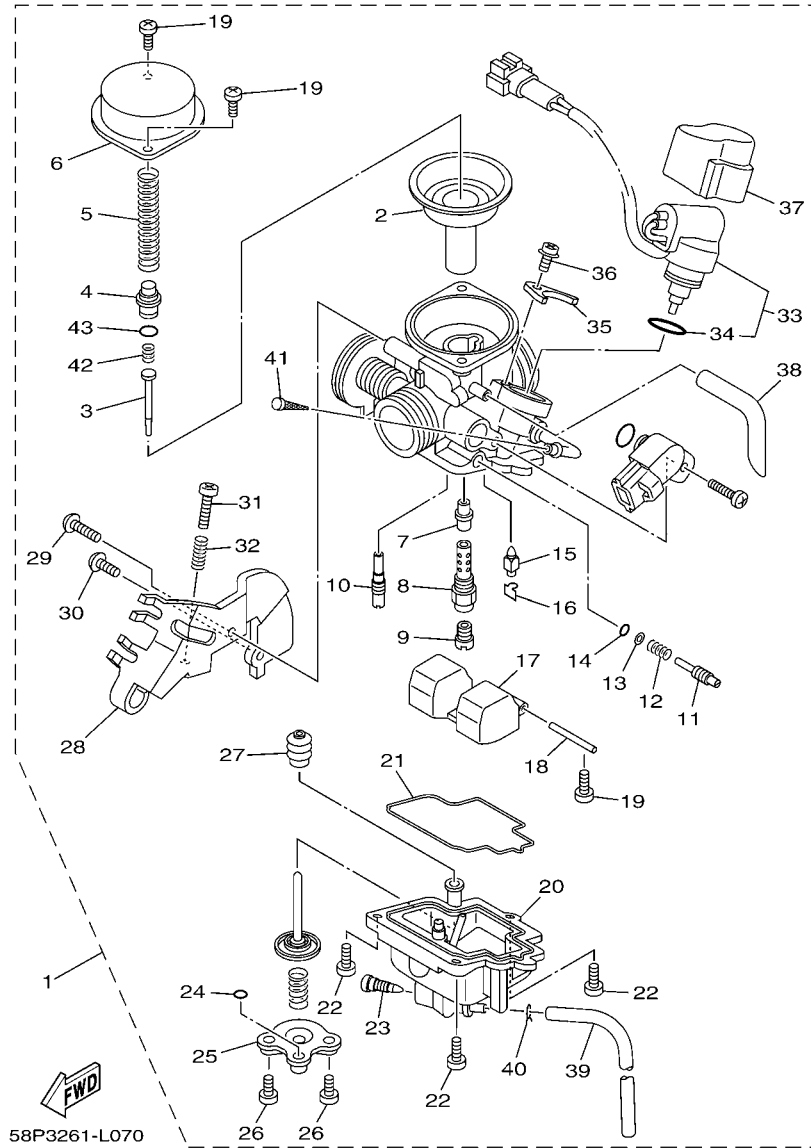


FIG. 7 CARBURADOR

CARBURETOR

REF. N°	CODIGO N° PART NO.	DESCRIPCION DESCRIPTION	2DU4				OBSERVACIONES REMARKS
28	5UA-E4926-00	.SOPORTE DE OBTURADOR 1 .BRACKET, THROTTLE 1	1				
29	5TY-E4245-00	.TORNILLO DE GUIA .SCREW, GUIDE	1				
30	5TY-E4245-10	.TORNILLO DE GUIA .SCREW, GUIDE	1				
31	5TY-E4922-00	.TORNILLO DE OBTURADOR .SCREW, THROTTLE	1				
32	5JG-14531-00	.RESORTE TORNILLO AJUSTE .SPRING, ADJUST SCREW	1				
33	24P-E4493-20	.EMBOLO CONJUNTO .PLUNGER STARTER ASSY	1				
34	5ML-E4854-00	.ANILLO-O .O-RING	1				
35	5ML-E4945-00	.PLACA .PLATE	1				
36	5TY-E4871-00	.TORNILLO .SCREW	1				
37	5TY-E4967-00	.CUBIERTA .COVER	1				
38	5TY-E4197-20	.TUBO RESPIRADERO .PIPE	1				
39	24P-E4196-00	.TUBO DE DRENASE .PIPE, OVER FLOW 1	1				
40	5BE-14937-00	.PRESILLA .CLIP	1				
41	5TY-E4994-00	.FILTRO .NET, FILTER	1				
42	5ML-E4935-00	.RESORTE .SPRING	1				
43	3TJ-14564-40	.ANILLO O .O-RING	1				

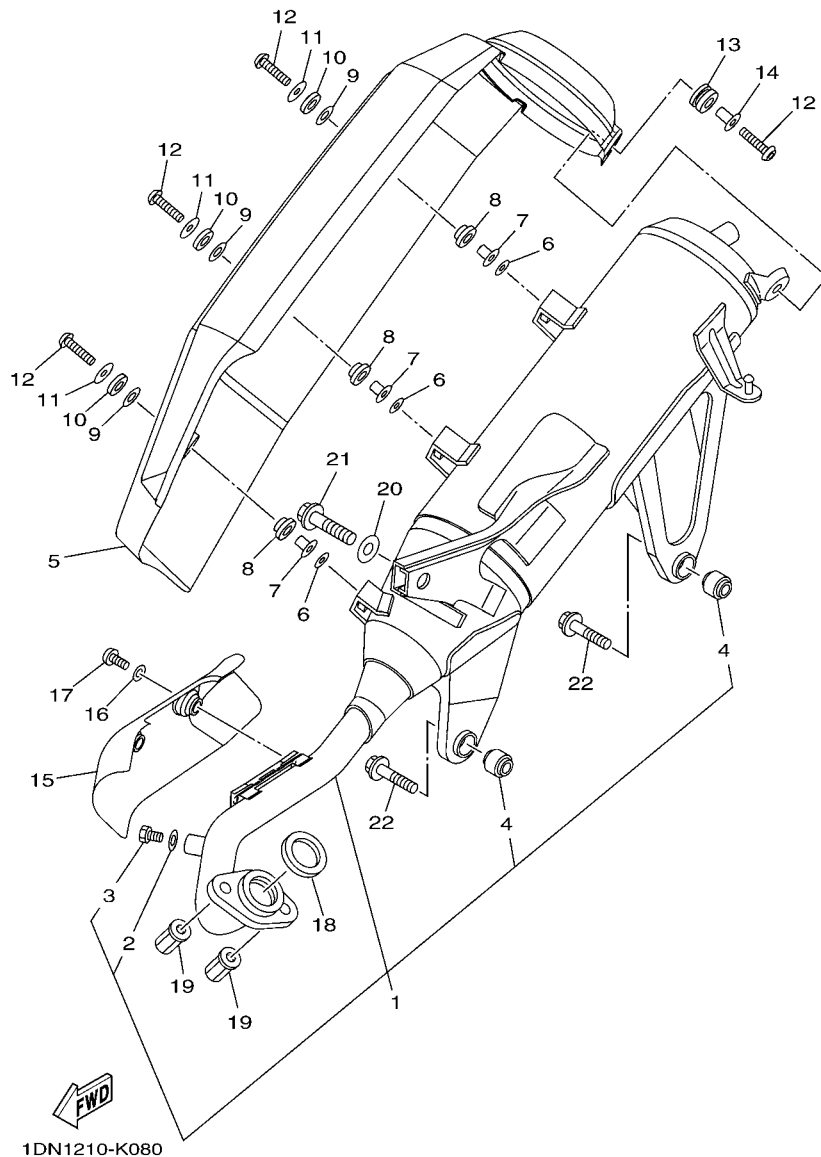


FIG. 8 DESCARGA

EXHAUST

REF. N°	CODIGO N° PART NO.	DESCRIPCION DESCRIPTION	2DU4				OBSERVACIONES REMARKS
1	58P-E4610-10	TUBO DE ESCAPE COMPLETO 1 EXHAUST PIPE ASSY 1	1				
2	92990-06600	.ARANDELA PLANA .WASHER, PLATE	1				
3	97080-06008	.PERNO .BOLT, HEX.	1				
4	5ML-E4737-10	.AMORTIGUADOR DE SILENCIADOR .DAMPER, MUFFLER	2				
5	1CE-E4708-00	PROTECTOR COMPLETA PROTECTOR ASSY	1				
6	4CW-E4766-00	ARANDELA DE PROTECTOR WASHER, PROTECTOR	3				
7	5JS-E4779-00	COLLAR COLLAR	3				
8	5JS-E4445-00	TAPON PROTECTOR GROMMET	3				
9	5JS-E4759-00	ARANDELA WASHER	3				
10	5JS-E4617-00	ARANDELA WASHER	3				
11	90201-06055	ARANDELA PLANA WASHER, PLATE	3				
12	90111-06801	TORNILLO BOLT,HEX. SOCKET BUTTON	4				
13	90480-14810	TAPON GROMMET	1				
14	90387-061N6	ESPACIADOR COLLAR	1				
15	1CE-E4628-00	PROTECTOR DE TUBO DE ESCAPE PROTECTOR, EXHAUST PIPE	1				
16	92990-06200	ARANDELA PLANA WASHER, PLAIN	2				
17	98980-06016	TORNILLO DE LIGAR SCREW, BIND	2				
18	4DH-14613-00	JUNTA, TUBO DE ESCAPE GASKET, EXHAUST PIPE	1				
19	90179-08804	TUERCA NUT	2				
20	90201-101J1	ARANDELA PLANA WASHER, PLATE	1				
21	95817-10035	TORNILLO BOLT, FLANGE	1				
22	90105-08835	TORNILLO BOLT, FLANGE	2				

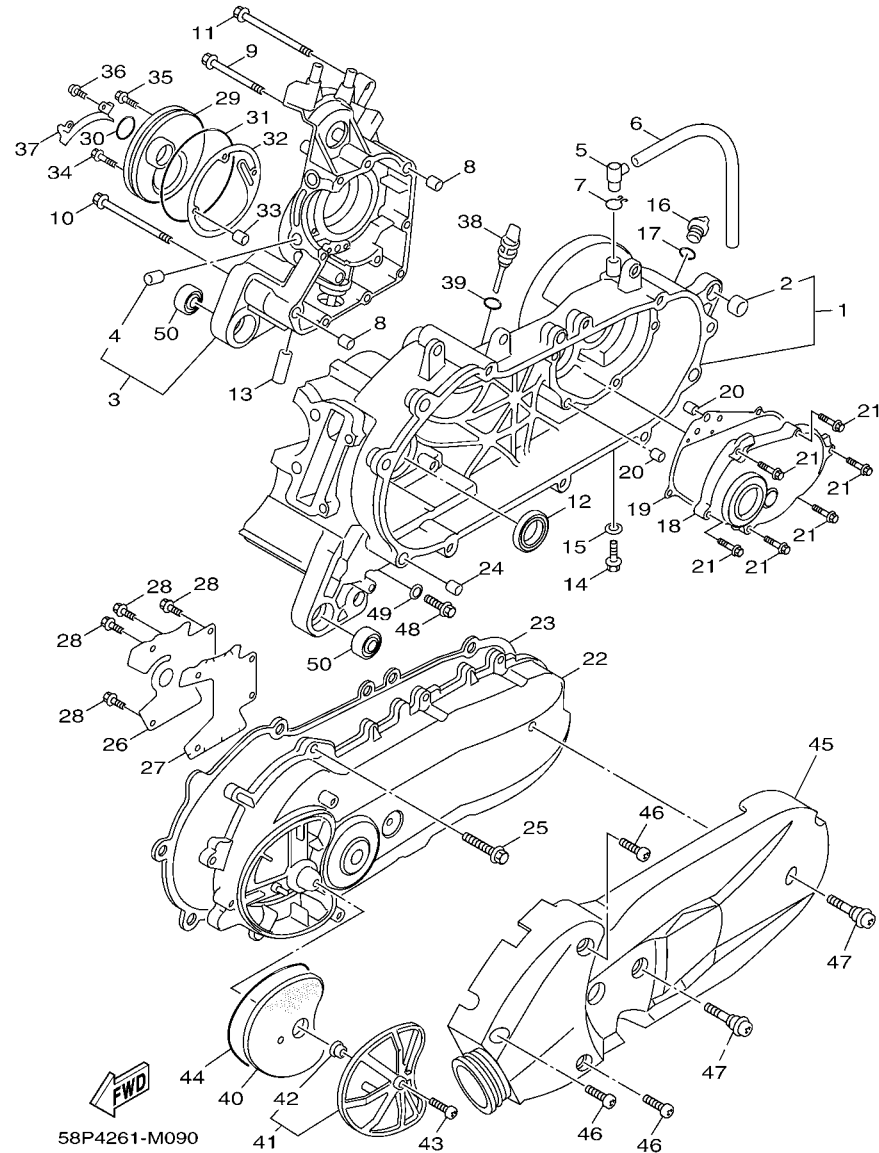


FIG. 9 CARTER

CRANKCASE

REF. Nº	CODIGO Nº PART NO.	DESCRIPCION DESCRIPTION	2DU4				OBSERVACIONES REMARKS
1	5S9-WE511-01	CARTER, MANIVELA 1 CRANKCASE 1	1				
2	4X6-F2216-00	.BUJE DEL AMORTIGUADOR TRASERO .BUSH, REAR SHOCK ABSORBER	1				
3	5S9-WE512-00	CARTER 2 CRANKCASE 2	1				
4	5ML-E5138-00	.BOQUILLA 1 .NOZZLE 1	1				
5	5CA-E5371-00	RESPIRADERO BREATHER	1				
6	90446-13803	TUBO RESEIRADERO HOSE	1				
7	90467-12052	PRESILLA CLIP	1				
8	91810-14807	PASADOR DE CLAVIJA PIN, DOWEL	2				
9	90105-06808	TORNILLO BOLT, FLANGE	6				
10	90105-06810	TORNILLO BOLT, FLANGE	1				
11	90105-06817	TORNILLO BOLT, FLANGE	1				
12	93102-22843	SELLO ACEITE OIL SEAL	1				
13	5ML-E3416-00	TUBO DE ACEITE 1 PIPE, OIL 1	1				
14	95817-08016	TORNILLO BOLT, FLANGE	1				
15	90430-08816	JUNTA GASKET	1				
16	4Y4-E5363-00	TÁPÓN DE ACEITE PLUG, OIL	1				
17	93210-14805	ANILLO O O-RING	1				
18	5S9-E5421-02	TAPA DE CARTER DERECHA COVER, CRANKCASE 2	1				
19	5S9-E5461-00	JUNTA TAPA CARTER DERECHO 2 GASKET, CRANKCASE COVER 2	1				
20	91810-14807	PASADOR DE CLAVIJA PIN, DOWEL	2				
21	90105-06895	TORNILLO BOLT, FLANGE	8				
22	24P-E5411-01	CUBIERTA DE CARTER 1 COVER, CRANKCASE 1	1				
23	5S9-E5451-10	EMPAQ DE CUBIERTA DE CARTER GASKET, CRANKCASE COVER 1	1				
24	91810-14807	PASADOR DE CLAVIJA PIN, DOWEL	2				
25	95027-06025	PERNO, DE BRIDA BOLT, FLANGE	9				
26	5ML-E5191-00	PLACA PLATE	1				
27	5ML-E5455-00	EMPAQUE 1 GASKET 1	1				

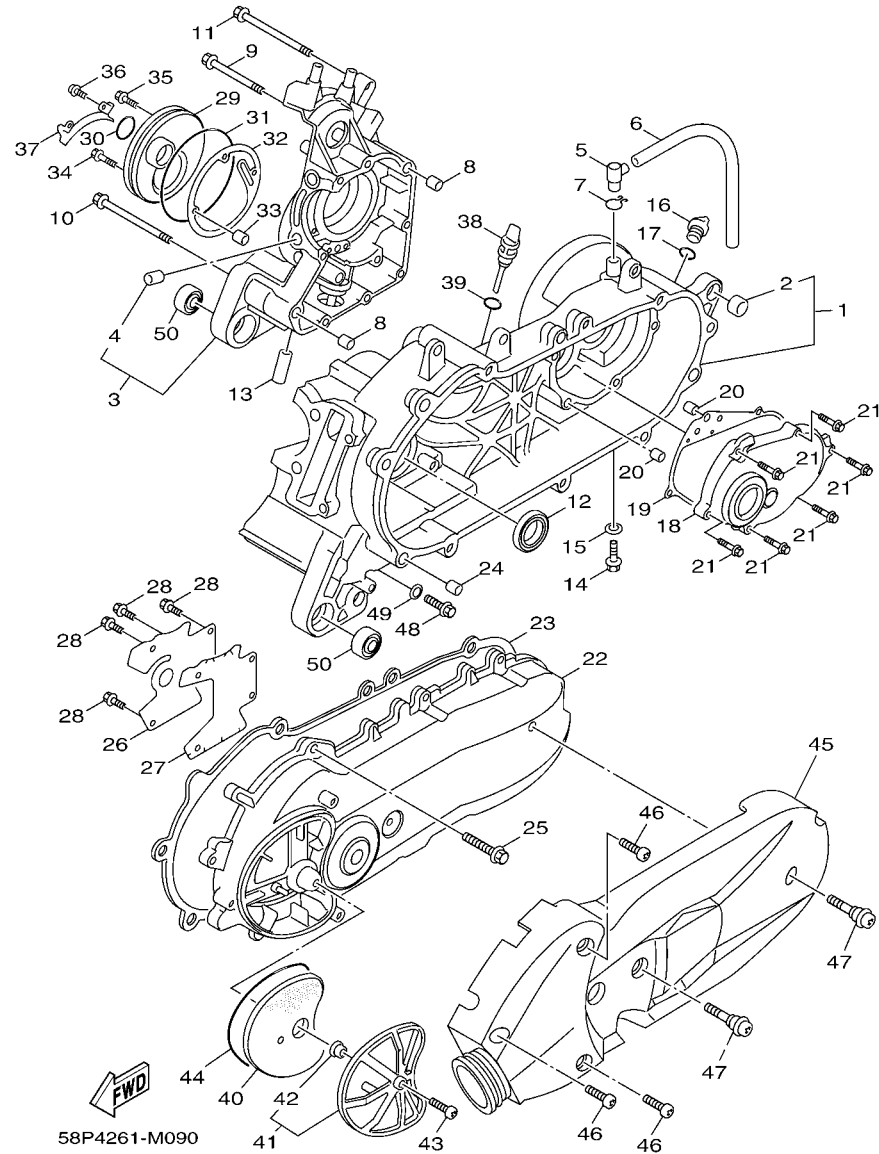


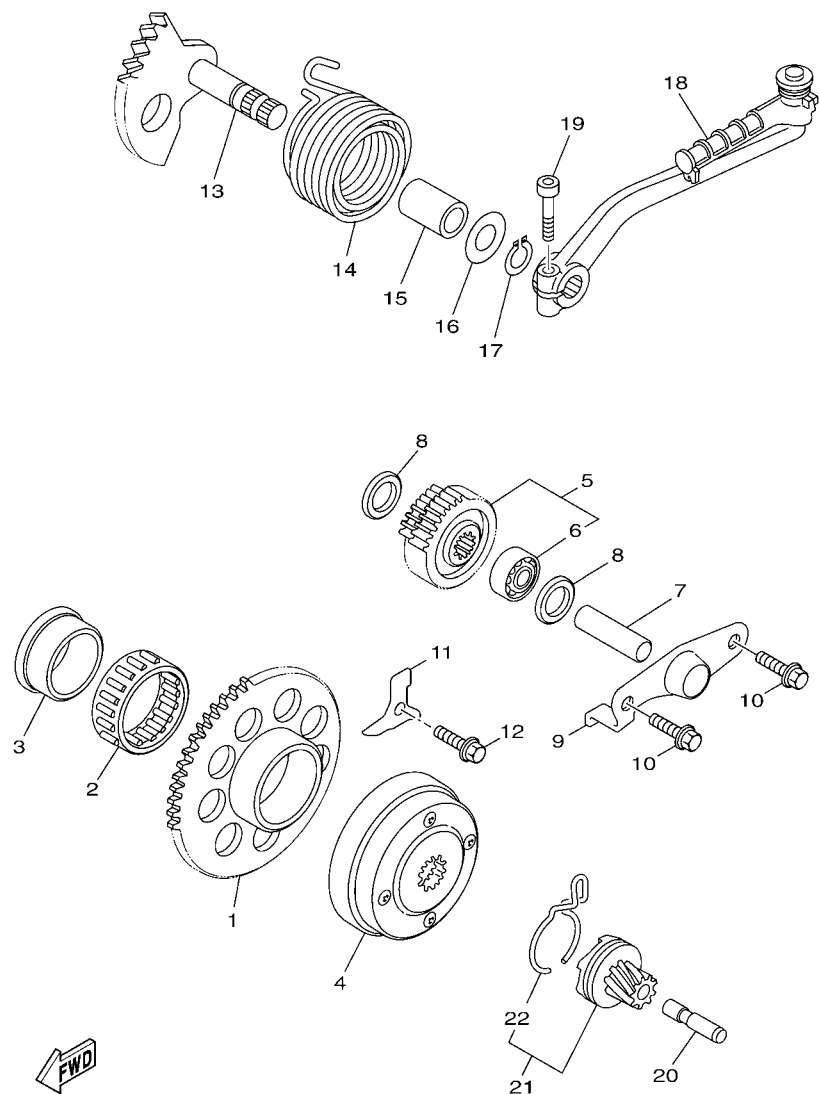
FIG. 9 CARTER

CRANKCASE

REF. Nº	CODIGO Nº PART NO.	DESCRIPCION DESCRIPTION	2DU4				OBSERVACIONES REMARKS
28	95027-06010	PERNO, DE BRIDA BOLT, FLANGE	4				
29	5ML-E5417-00	CUBIERTA DE TAPA COVER, CAP	1				
30	93102-19293	SELLO ACEITE OIL SEAL	1				
31	93211-07801	ANILLO O O-RING	1				
32	5ML-E5453-00	EMPAQ GASKET	1				
33	99480-05010	PASADOR PIN	1				
34	90105-06809	TORNILLO BOLT, FLANGE	2				
35	90105-06807	TORNILLO BOLT, FLANGE	1				
36	90105-06806	TORNILLO BOLT, FLANGE	1				
37	5ML-E5113-00	PLACA PLATE	1				
38	5S9-E5362-00	TAPON DEL NIVEL DE ACEITE PLUG, OIL LEVEL	1				
39	5ML-E3769-00	ANILLO O O-RING	1				
40	5ML-E5407-00	ELEMENTO 1 ELEMENT 1	1				
41	5ML-E5404-00	COJINETE DE RODILLOS GUIDE, ELEMENT	1				
42	90387-06819	.ESPACIADOR .COLLAR	1				
43	90154-06826	TORNILLO DE LIGAR SCREW, BINDING	1				
44	5ML-E5472-00	SELLO DE CONDUCTO DE AIRE SEAL, AIR DUCT	1				
45	58P-XE543-00	CUBIERTA DE CARTER 3 COVER, CRANKCASE 3	1				
46	90154-06827	TORNILLO DE LIGAR SCREW, BINDING	3				
47	4DM-E5481-00	PERNO 1 BOLT 1	2				
48	90340-12802	TORNILLO, DE DRENAJE PLUG, STRAIGHT SCREW	1				
49	90201-12172	ARANDELA PLANA WASHER, PLATE	1				
50	93306-003Y4	COJINETE BEARING	2				

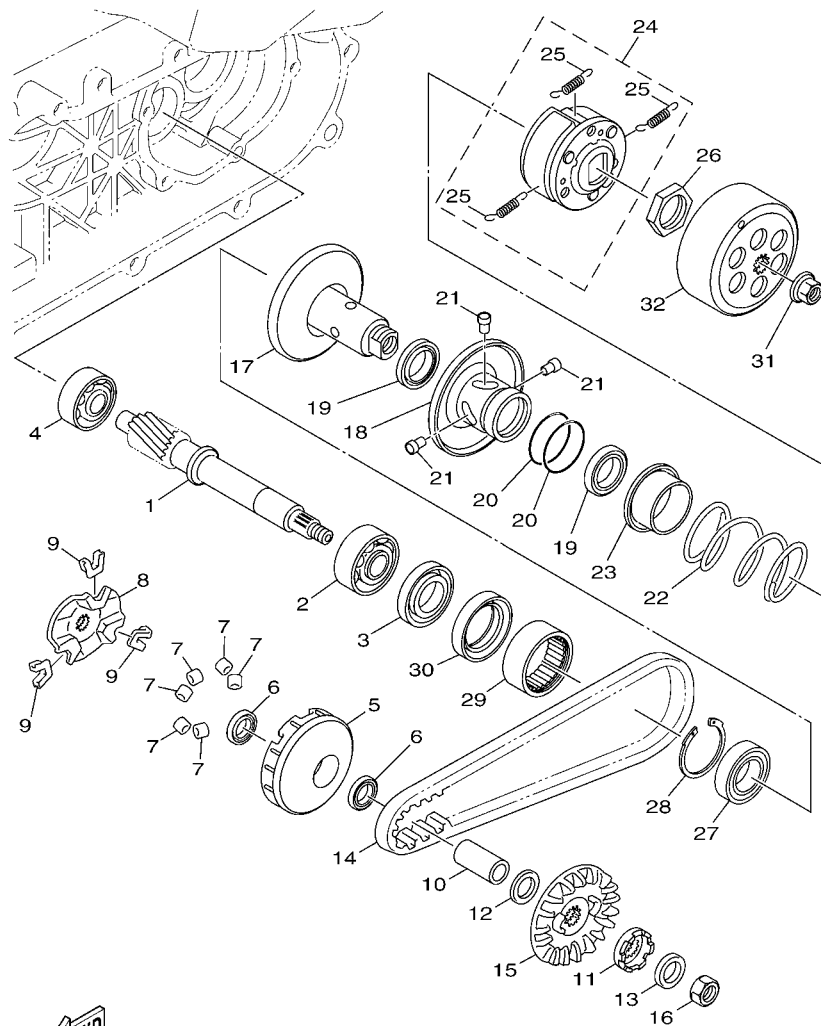
FIG. 10 ARRANQUE

STARTER



  
24S1210-H100

REF. N°	CODIGO N° PART NO.	DESCRIPCION DESCRIPTION	2DU4				OBSERVACIONES REMARKS
1	5S9-E5524-00	RUEDA DE ARRANQUE WHEEL, STARTER	1				
2	93310-450X2	COJINETE DE RODILLOS BEARING	1				
3	5LW-E5538-00	COPA 2 BOSS, GEAR 2	1				
4	5TY-E5570-01	EMBRAGUE DEL ARRANQUE COMPLETA STARTER CLUTCH ASSY	1				
5	5S9-E5650-00	ENGRENAJE NEUTRO COMPLETO IDLE GEAR ASSY	1				
6	93315-110Y6	.COJINETE DE RODILLOS .BEARING	1				
7	5CA-E5521-00	EJE 1 SHAFT 1	1				
8	90201-108A3	ARANDELA PLANA WASHER, PLATE	2				
9	5S9-E5532-00	PLACA DE ENGRENAGE NEUTRO PLATE, IDLE GEAR	1				
10	95027-06012	PERNO, DE BRIDA BOLT, FLANGE	2				
11	5TY-E5645-00	FLACA PLATE	1				
12	95027-06012	PERNO, DE BRIDA BOLT, FLANGE	1				
13	5ML-E5601-01	EJE DE ARR. DE PIE COMPL KICK SHAFT ASSY	1				
14	90508-32609	RESORTE DE TORSION SPRING, TORSION	1				
15	90380-15817	CASQUILLO SOLIDO BUSH, SOLID	1				
16	90201-155G5	ARANDELA PLANA WASHER, PLATE	1				
17	99009-15400	PRESILLA REDONDA CIRCLIP	1				
18	5ML-E5620-00	PEDAL DE ARRANQUE COMPLETO KICK CRANK ASSY	1				
19	91317-06030	PERNO BOLT	1				
20	5ML-E5659-00	EJE SHAFT	1				
21	5ML-E5670-00	PINON DE PEDAL COMPLETA 2 KICK PINION ASSY 2	1				
22	5ML-E5673-00	.PRESILLA .CLIP	1				



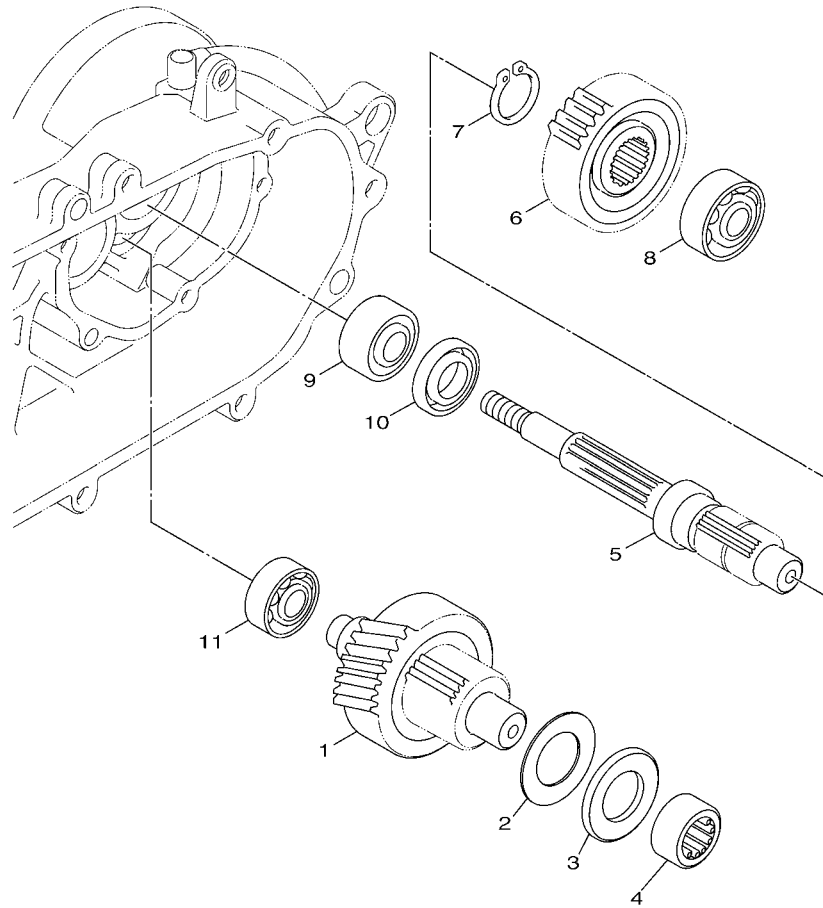
58P8261-P110

FIG. 11 EMBRAGUE

CLUTCH

REF. Nº	CODIGO Nº PART NO.	DESCRIPCION DESCRIPTION	2DU4				OBSERVACIONES REMARKS
1	5CA-E6111-01	ENGRANAJE TRACC.PRIMARIA GEAR, PRIMARY DRIVE	1				
2	93306-272X0	COJINETE BEARING	1				
3	93102-22800	SELLO ACEITE OIL SEAL	1				
4	93306-203YS	COJINETE BEARING	1				
5	5ML-E7620-02	ROLDANA PRIMARIA MOVIL PRIMARY SLIDING SHEAVE COMP.	1				
6	93101-21170	SELLO ACEITE OIL SEAL	2				
7	24P-E7632-00	CONTRAPESO WEIGHT	6				
8	5ML-E7623-00	LEVA CAM	1				
9	4CW-E7653-00	CORREDERA SLIDER	3				
10	90387-16801	ESPACIADOR COLLAR	1				
11	5ML-E5657-00	EMBRAGUE SIN RETORNO CLUTCH, ONEWAY	1				
12	90208-12050	ARANDELA DE RESORTE CONICO WASHER, CONICAL SPRING	1				
13	90201-168S9	ARANDELA PLANA WASHER, PLATE	1				
14	5S9-E7641-00	CORREA EN V V-BELT	1				
15	4HP-E7611-00	PISCO FIXADOR DE POREA SHEAVE, PRIMARY FIXED	1				
16	95307-12700	TUERCA NUT	1				
17	4CW-E7660-20	ROLDANA SECUNDARIA FIJA COMPL. SECONDARY FIXED SHEAVE COMP.	1				
18	5S9-E7670-10	ROLDANA SECUNDARIA CORREDIZA SECONDARY SLIDING SHEAVE	1				
19	93104-41119	SELLO ACEITE OIL SEAL	2				
20	93210-43800	ANILLO O O-RING	2				
21	4CW-E7664-00	PASADOR DE GUIA PIN, GUIDE	3				
22	90501-45801	RESORTE DE COMPRESION SPRING, COMPRESSION	1				
23	5TY-E7644-01	ASIENTO DE RESORTE SEAT, SPRING	1				
24	1P5-E6620-10	PORTADOR DE EMBRAGUE COMPLETO CLUTCH CARRIER ASSY	1				
25	1P5-E6626-00	RESORTE CONTRAPESO EMBRAGUE 1 SPRING, CLUTCH WEIGHT 1	3				
26	90170-36279	TUERCA NUT	1				
27	93306-903Y1	COJINETE BEARING	1				





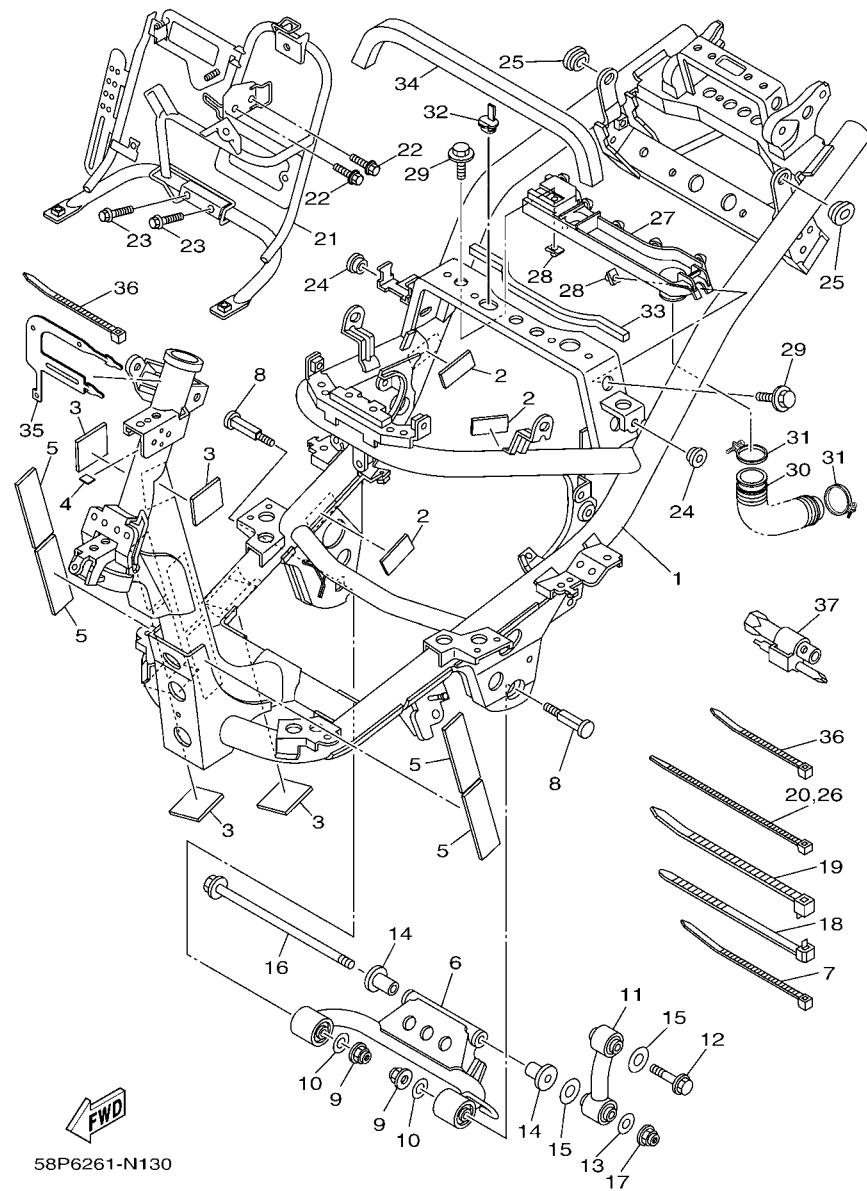
  
24P1261-H120

FIG. 12 TRANSMISION

TRANSMISION

REF. Nº	CODIGO Nº PART NO.	DESCRIPCION DESCRIPTION	2DU4				OBSERVACIONES REMARKS
1	5S9-E7410-00	EJE PRINCIPAL COMPLETO(11/40T) MAIN AXLE COMP. (11/40T)	1				
2	90201-15831	ARANDELA PLANA WASHER, PLATE	1				
3	90201-15803	ARANDELA PLANA WASHER, PLATE	1				
4	93311-315Y2	COJINETE DE RODILLOS BEARING	1				
5	5S9-E7421-00	EJE SECUNDARIO AXLE, DRIVE	1				
6	5S9-E7211-00	ENGRANAJE RUEDA DE 1 RA (44T) GEAR, 1ST WHEEL (44T)	1				
7	99009-25400	PRESILLA REDONDA CIRCLIP	1				
8	93306-303Y8	COJINETE BEARING	1				
9	93306-272Y0	COJINETE BEARING	1				
10	93102-32800	SELLO ACEITE OIL SEAL	1				
11	93306-301YL	COJINETE BEARING	1				



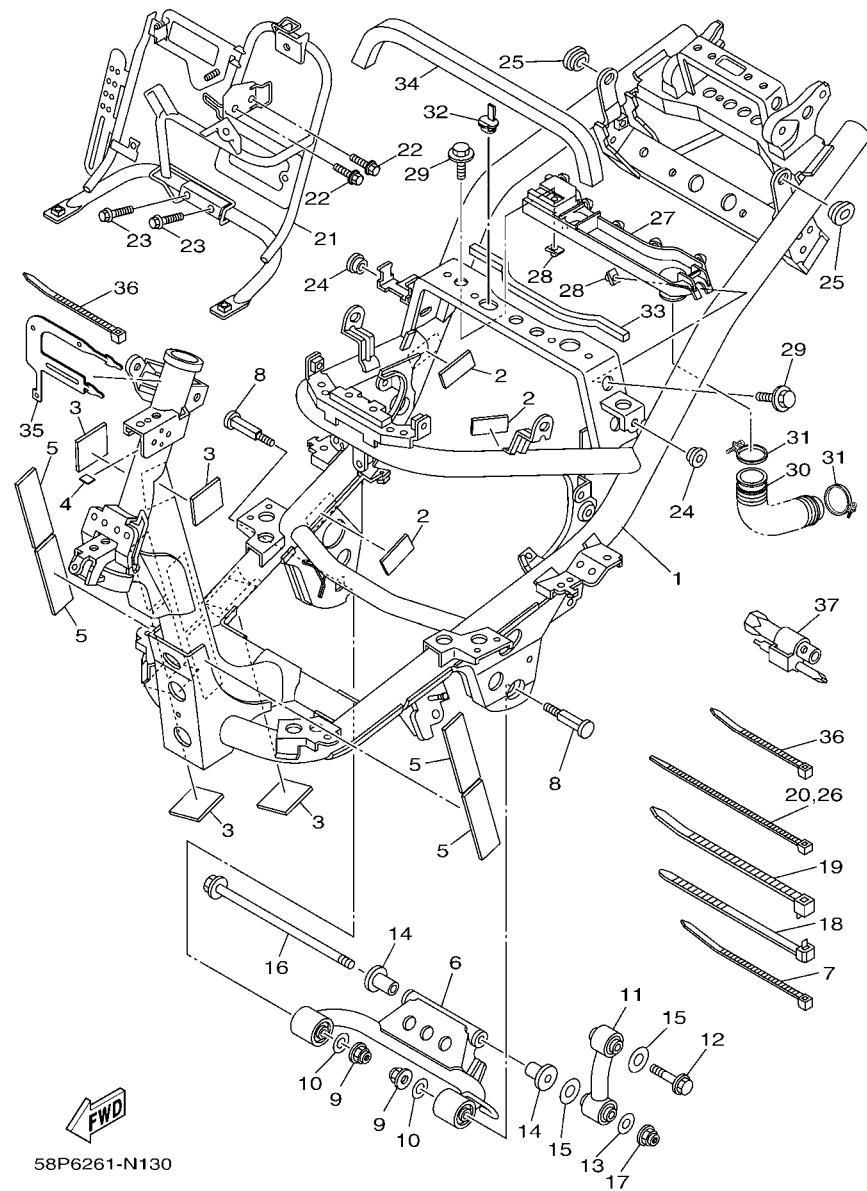


58P6261-N130

FIG. 13 CUADRO

FRAME

REF. N°	CODIGO N° PART NO.	DESCRIPCION DESCRIPTION	2DU4			OBSERVACIONES REMARKS
1	58P-F1110-10-P0	ARMAZON COMPLETO FRAME COMP.	1			UR VPBM2 PARA A UR VPBM2 FOR A
	58P-F1110-10-P1	ARMAZON COMPLETO FRAME COMP.	1			UR MT1 PARA B UR MT1 FOR B
	58P-F1110-10-7M	ARMAZON COMPLETO FRAME COMP.	1			UR MDS PARA C,D,E UR MDS FOR C,D,E
2	5ML-F1541-00	AMORTIGUADOR 1 DAMPER 1	3			
3	90520-02834	EQUILIBRIO, CUBIERTA DAMPER, PLATE	4			
4	90520-01801	EQUILIBRIO, CUBIERTA DAMPER, PLATE	1			
5	5SU-F622F-00	AMORTIGUADOR, DE UBICACION 1 DAMPER, LOCATING 1	4			
6	5S9-F1420-00	SOPORTE DE MOTOR COMPLETO ENGINE BRACKET COMP. 2	1			
7	90464-40801	BRIDA CLAMP	1			
8	3UH-F1481-00	PERNO DE MONTAJE DE MOTOR 1 BOLT, ENGINE MOUNTING 1	2			
9	90185-10801	TUERCA AUTOBLOCANTE NUT, SELF-LOCKING	2			
10	90201-105A2	ARANDELA PLANA WASHER, PLATE	2			
11	5ML-F1480-10	SOPORTE DE MOTOR STAY, ENGINE	1			
12	5S9-F1482-00	PERNO DE MONTAJE DE MOTOR 2 BOLT, ENGINE MOUNTING 2	1			
13	90201-105A2	ARANDELA PLANA WASHER, PLATE	1			
14	5ML-F1544-01	COLLAR 1 COLLAR 1	2			
15	90202-15803	ARANDELA DE PLANA WASHER, PLATE	2			
16	5ML-F1481-00	PERNO DE MONTAJE DE MOTOR 1 BOLT, ENGINE MOUNTING 1	1			
17	90185-10801	TUERCA AUTOBLOCANTE NUT, SELF-LOCKING	1			
18	90464-12812	BRIDA CLAMP	2			
19	4C7-H2594-00	GRAMPA CLAMP	1			
20	90464-60800	BRIDA CLAMP	1			
21	2DU-F128A-00	MENSULA DE REGULADOR BRACKET, REGULATOR	1			
22	95807-06010	TORNILLO BOLT, FLANGE	2			
23	95817-08030	TORNILLO BOLT, FLANGE	2			
24	90480-13814	TAPON GROMMET	2			
25	90480-01558	TAPON GROMMET	4			



58P6261-N130

FIG. 13 CUADRO

FRAME

REF. Nº	CODIGO Nº PART NO.	DESCRIPCION DESCRIPTION	2DU4				OBSERVACIONES REMARKS
26	90464-60800	BRIDA CLAMP	1				
27	58P-F110F-00	CONDUCTO 1 DUCT 1	1				
28	90183-06813	TUERCA DE RESORTE NUT, SPRING	2				
29	90119-06096	TORNILLO CON ARANDELA BOLT, WITH WASHER	2				
30	58P-F110G-01	CONDUCTO 2 DUCT 2	1				
31	58P-F1823-00	GRAMPA DE MANGUERA CLAMP, HOSE	2				
32	58P-F6199-00	TAPON PLUG, BLIND	1				
33	90520-10816	EQUILIBRIO, CUBIERTA DAMPER, PLATE	1				
34	90520-20812	EQUILIBRIO, CUBIERTA DAMPER, PLATE	1				
35	58P-F162H-00	CHARNELA 3 FLAP 3	1				
36	90464-26800	BRIDA CLAMP	3				
37	24P-F8100-00	JUEGO DE HERRAMIENTAS TOOL KIT	1				

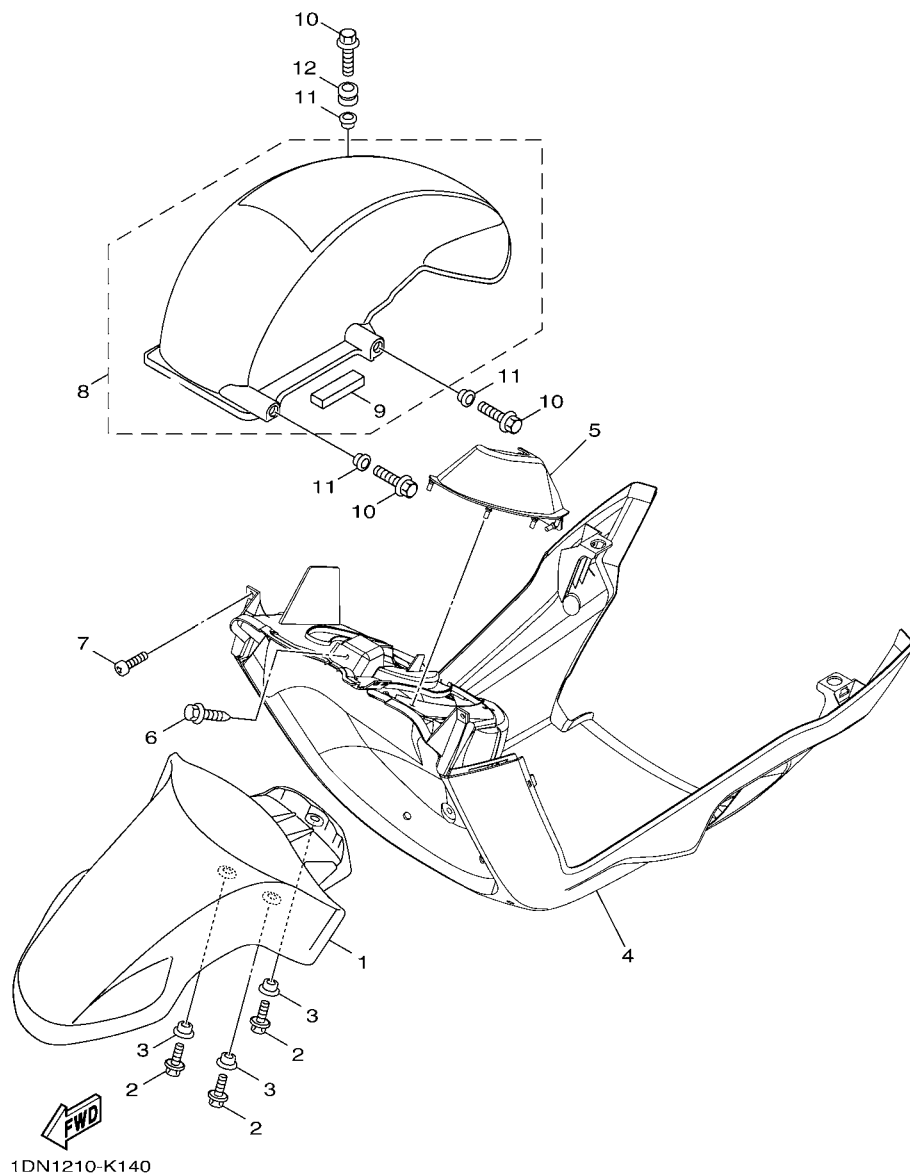


FIG. 14 GUARDABARRO DELANTERO FRONT FENDER

REF. N°	CODIGO N° PART NO.	DESCRIPCION DESCRIPTION	2DU4				OBSERVACIONES REMARKS
1	58P-F1511-01	GUARDABARRO DELANTERO FENDER, FRONT	1				
2	90119-06821	TORNILLO CON ARANDELA BOLT, WITH WASHER	3				
3	90387-068F8	ESPACIADOR COLLAR	3				
4	5S9-F1552-02	GUARDABARRO FENDER, INNER	1				
5	5ML-F151B-00	TAPA CAP	1				
6	90119-06821	TORNILLO CON ARANDELA BOLT, WITH WASHER	1				
7	97707-50016	TORNILLO SCREW, TRUSS HEAD TAPPING	2				
8	5S9-XF161-00	GUARDABARRO TRASERO FENDER, REAR	1				
9	5CA-F1639-00	.AMORTIGUADOR 2 .DAMPER 2	1				
10	95807-06016	TORNILLO BOLT, FLANGE	3				
11	90387-06868	ESPACIADOR COLLAR	3				
12	90480-12813	TAPON GROMMET	1				

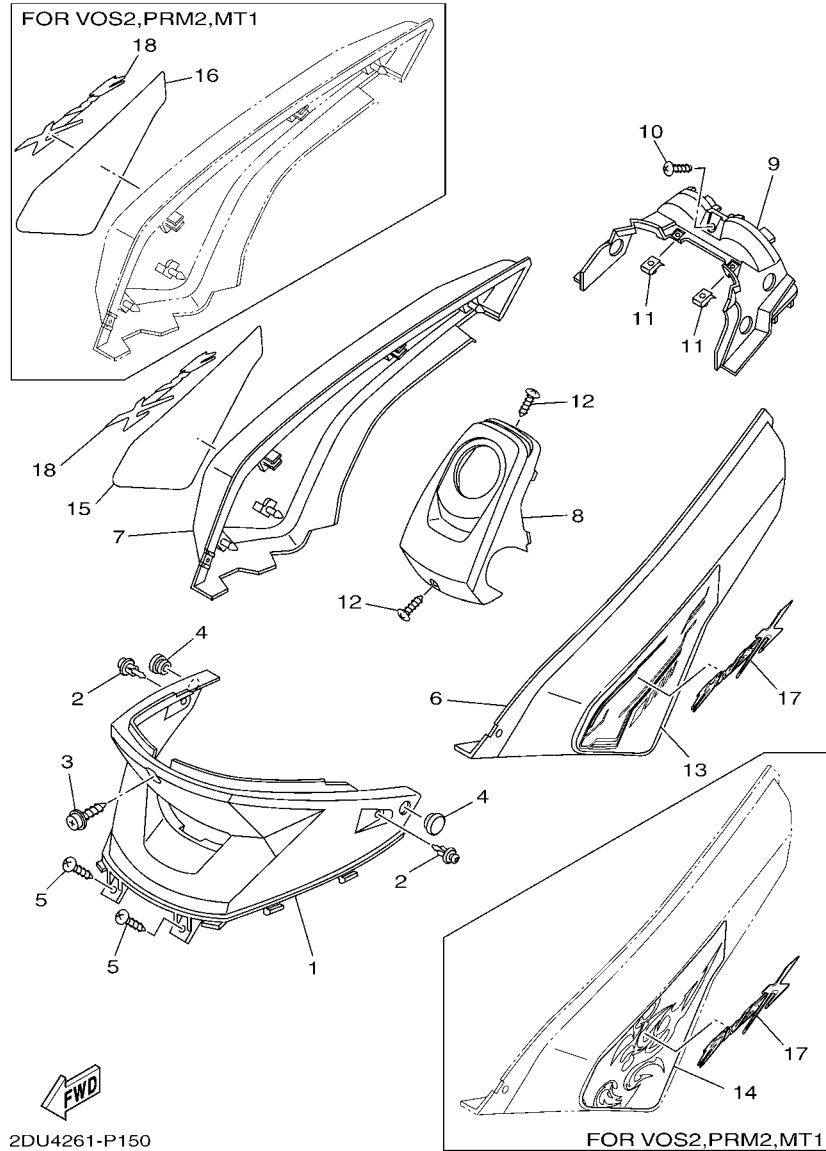


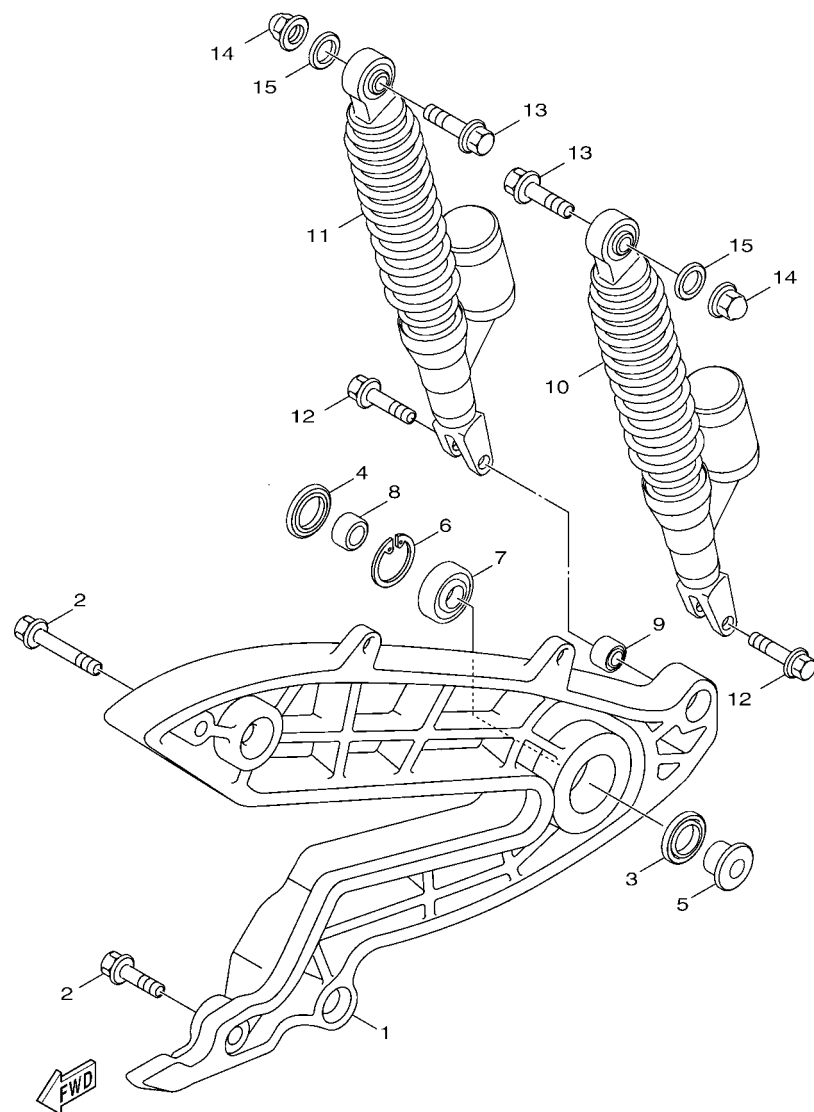
FIG. 15 CUBIERTA LATERAL

SIDE COVER

REF. Nº	CODIGO Nº PART NO.	DESCRIPCION DESCRIPTION	2DU4			OBSERVACIONES REMARKS
1	5S9-F1711-00	CUBIERTA LATERAL 1 COVER, SIDE 1	1			
2	90269-06806	REMACHE RIVET	2			
3	90159-06812	TORNILLO CON VALONA SCREW, WITH WASHER	1			
4	4DH-F6199-01	TAPON PLUG, BLIND	2			
5	97707-50012	TORNILLO SCREW, TRUSS HEAD TAPPING	2			
6	58P-F1721-00-P1	CUBIERTA LATERAL 2 COVER, SIDE 2	1			UR PARA SMX
	58P-F1721-00-P4	CUBIERTA LATERAL 2 COVER, SIDE 2	1			UR FOR SMX
	58P-F1721-00-P3	CUBIERTA LATERAL 2 COVER, SIDE 2	1			UR PARA WM1
	58P-F1721-00-PB	CUBIERTA LATERAL 2 COVER, SIDE 2	1			UR FOR WM1
	58P-F1721-00-PA	CUBIERTA LATERAL 2 COVER, SIDE 2	1			UR PARA VOS2
						UR FOR VOS2
						UR PARA PRM2
						UR FOR PRM2
						UR PARA MT1
						UR FOR MT1
7	58P-F1731-00-P1	TAPA LATERAL 3 COVER, SIDE 3	1			UR PARA SMX
	58P-F1731-00-P4	TAPA LATERAL 3 COVER, SIDE 3	1			UR FOR SMX
	58P-F1731-00-P3	TAPA LATERAL 3 COVER, SIDE 3	1			UR PARA WM1
	58P-F1731-00-PC	TAPA LATERAL 3 COVER, SIDE 3	1			UR FOR WM1
	58P-F1731-00-PB	TAPA LATERAL 3 COVER, SIDE 3	1			UR PARA VOS2
						UR FOR VOS2
						UR PARA PRM2
						UR FOR PRM2
						UR PARA MT1
						UR FOR MT1
8	5S9-F1741-00	TAPA LATERAL 4 COVER, SIDE 4	1			
9	5S9-F171E-00	CUBIERTA LATERAL 5 COVER, SIDE 5	1			
10	97707-50012	TORNILLO SCREW, TRUSS HEAD TAPPING	1			
11	90183-05807	TUERCA DE RESORTE NUT, SPRING	2			
12	97707-50012	TORNILLO SCREW, TRUSS HEAD TAPPING	2			
13	2DU-F1781-00	EMBLEMA 1 EMBLEM 1	1			UR PARA SMX
	2DU-F1781-10	EMBLEMA 1 EMBLEM 1	1			UR FOR SMX
						UR PARA WM1
						UR FOR WM1
14	2DU-F1783-00	EMBLEMA 3 EMBLEM 3	1			UR PARA VOS2
	2DU-F1783-10	EMBLEMA 3 EMBLEM 3	1			UR FOR VOS2
	2DU-F1783-20	EMBLEMA 3 EMBLEM 3	1			UR PARA PRM2
						UR FOR PRM2
						UR PARA MT1
						UR FOR MT1
15	2DU-F1782-00	EMBLEMA 2 EMBLEM 2	1			UR PARA SMX
	2DU-F1782-10	EMBLEMA 2 EMBLEM 2	1			UR FOR SMX
						UR PARA WM1
						UR FOR WM1

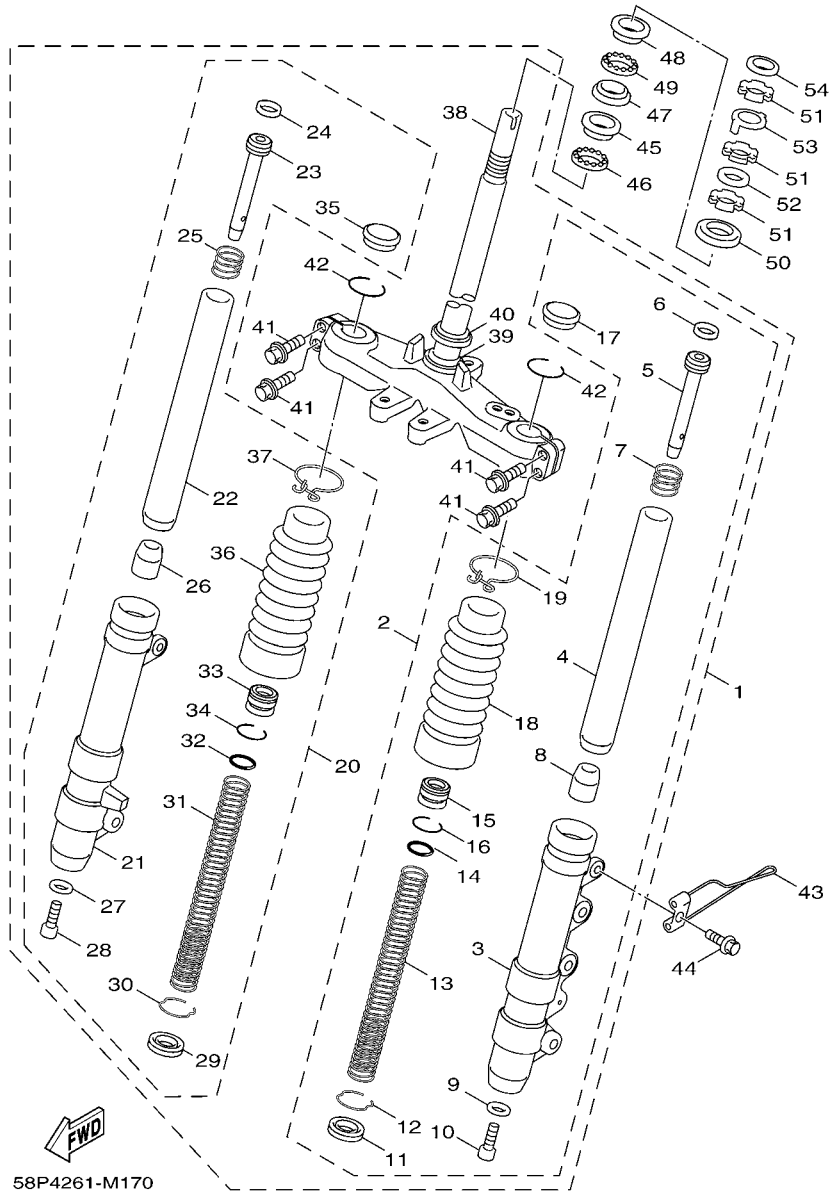


FIG. 16 BRAZO TRASERO & SUSPENSION REAR ARM & SUSPENSION



1DN1210-K160

REF. Nº	CODIGO Nº PART NO.	DESCRIPCION DESCRIPTION	2DU4				OBSERVACIONES REMARKS
1	46P-F2171-10	BRAZO POSTERIOR 1 ARM, REAR 1	1				
2	95827-08045	TORNILLO BOLT, FLANGE	2				
3	93109-28811	SELLO ACEITE OIL SEAL	1				
4	93106-28809	SELLO ACEITE OIL SEAL	1				
5	90387-153N8	ESPACIADOR COLLAR	1				
6	99009-42500	PRESILLA REDONDA CIRCLIP	1				
7	93306-302X1	COJINETE BEARING	1				
8	90387-15813	ESPACIADOR COLLAR	1				
9	4X6-F2216-00	BUJE DEL AMORTIGUADOR TRASERO BUSH, REAR SHOCK ABSORBER	1				
10	2DU-F2210-20	AMORTIGUADOR TRASERO COMPLETO SHOCK ABSORBER ASSY, REAR	1				UR PARA SMX UR FOR SMX
	2DU-F2210-30	AMORTIGUADOR TRASERO COMPLETO SHOCK ABSORBER ASSY, REAR	1				UR EXCEPT PARA SM UR EXCEPT FOR SMX
11	2DU-F2220-20	AMORTIGUADOR TRASERO COMPLETO SHOCK ABSORBER ASSY, REAR	1				UR PARA SMX UR FOR SMX
	2DU-F2220-30	AMORTIGUADOR TRASERO COMPLETO SHOCK ABSORBER ASSY, REAR	1				UR EXCEPT PARA SM UR EXCEPT FOR SMX
12	90105-088C0	TORNILLO BOLT, FLANGE	2				
13	90101-10875	TORNILLO BOLT	2				
14	95307-10800	TUERCA NUT	2				
15	90201-101J1	ARANDELA PLANA WASHER, PLATE	2				



58P4261-M170

FIG. 17 HORQUILLA DELANTERA FRONT FORK

REF. Nº	CODIGO Nº PART NO.	DESCRIPCION DESCRIPTION	2DU4			OBSERVACIONES REMARKS
1	46P-F3100-00	HORQUILLA DELANTERA COMPLETA FRONT FORK ASSY	1			
2	46P-F3102-00	..HORQUILLA DELANTERA COMPL.(MI) ..FRONT FORK ASSY (L.H)	1			
3	46P-F3126-00	..TUBO EXTERIOR (IZQUIERDO) ..TUBE, OUTER (L.H)	1			
4	5S9-F3110-00	..TUBO INTERIOR COMPLETO 1 ..INNER TUBE COMP.1	1			
5	5S9-F3142-00	..ASIENTO DEL MUELLE SUPERIOR ..SEAT, SPRING UPPER	1			
6	4C6-F318X-00	..ANILLO DE PISTON ..PISTON RING	1			
7	4C6-F3151-00	..RESORTE DE REBOTE ..SPRING, REBOUND	1			
8	4C6-F3171-00	..PISTON HORQUILLA DELANT. ..PISTON, FRONT FORK	1			
9	4C6-F3158-00	..EMPAQUE ..GASKET	1			
10	4C6-F3181-00	..TORNILLO CABEZAHEXAGONAL ..BOLT, HEXAGON SOCKET HEAD	1			
11	4C6-F3145-00	..RETÉN DE ACEÍTE ..OIL SEAL	1			(KAIFA) (KAIFA)
12	4C6-F3157-00	..ANILLO DEL PISTON ..RING, PISTON	1			
13	5S9-F3141-00	..RESORTE HORQUILLA DELANT. ..SPRING, FRONT FORK	1			
14	4C6-F3147-00	..ARO ..O-RING	1			(KAIFA) (KAIFA)
15	4C6-F3113-00	..COLLAR ..COLLAR	1			
16	4C6-F3155-00	..ANILLO DE FIELTRO ..RING, FELT	1			
17	4C6-F3154-00	..TAPON TUBO INTERIOR ..CAP	1			
18	4C6-F3191-00	..FUNDA ..BOOT	1			
19	4C6-F3192-00	..BANDA ..BAND	1			
20	46P-F3103-00	..HORQUILLA DELANTERA COMPL.(MD) ..FRONT FORK ASSY (R.H)	1			
21	46P-F3136-00	..TUBO EXTERIOR 2 ..TUBE, OUTER	1			
22	5S9-F3110-00	..TUBO INTERIOR COMPLETO 1 ..INNER TUBE COMP.1	1			
23	5S9-F3142-00	..ASIENTO DEL MUELLE SUPERIOR ..SEAT, SPRING UPPER	1			
24	4C6-F318X-00	..ANILLO DE PISTON ..PISTON RING	1			
25	4C6-F3151-00	..RESORTE DE REBOTE ..SPRING, REBOUND	1			
26	4C6-F3171-00	..PISTON HORQUILLA DELANT. ..PISTON, FRONT FORK	1			
27	4C6-F3158-00	..EMPAQUE ..GASKET	1			

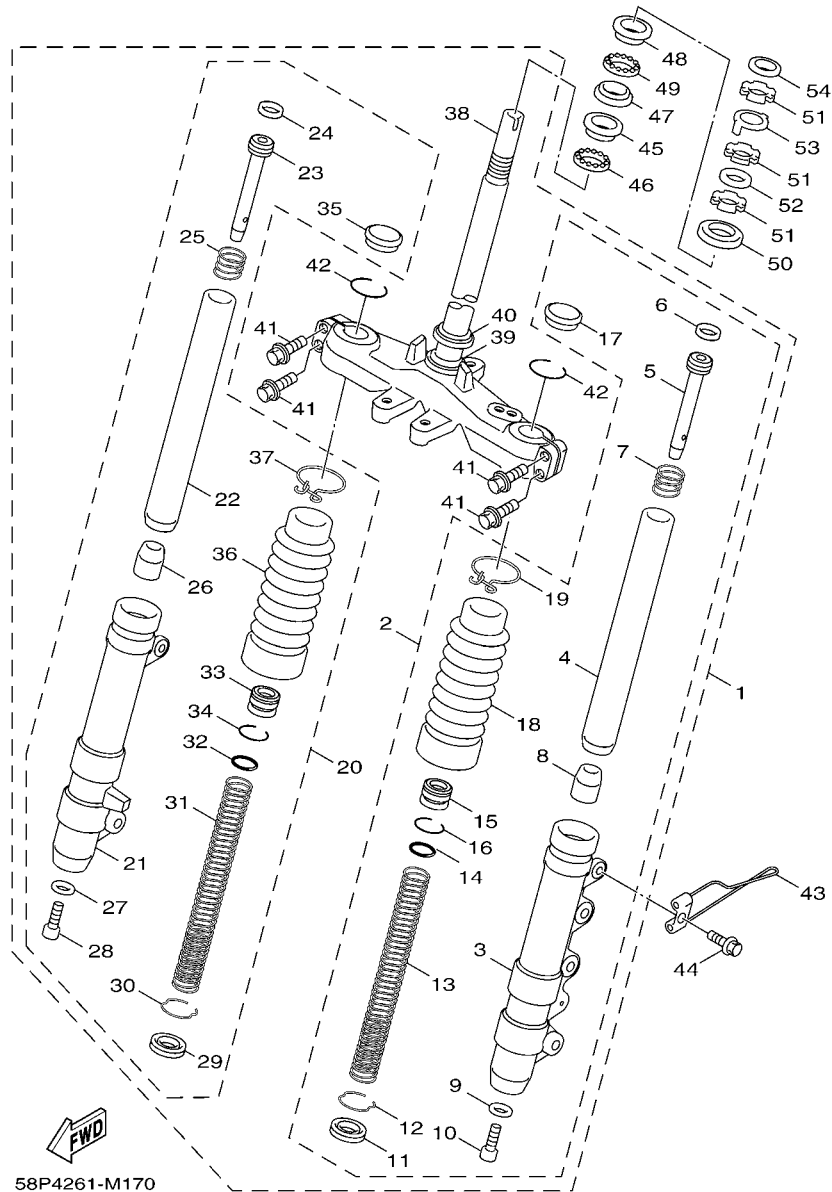
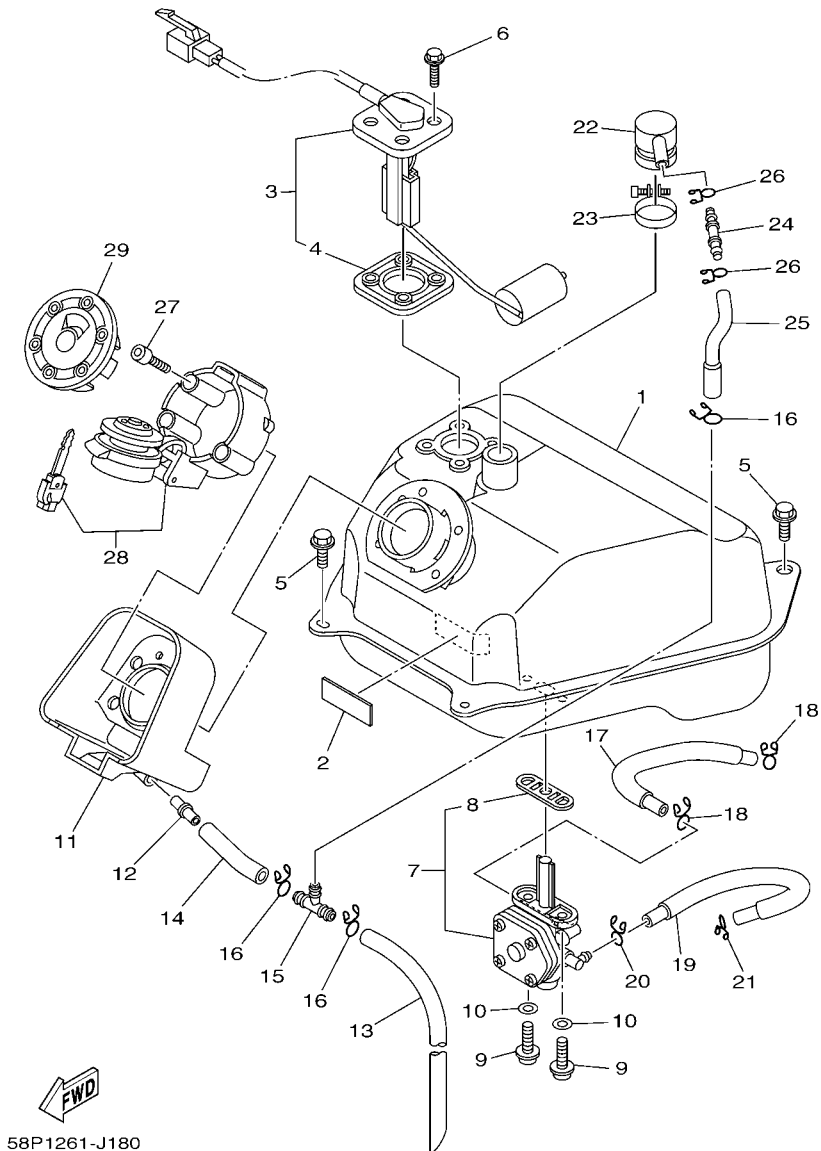


FIG. 17 HORQUILLA DELANTERA FRONT FORK

REF. Nº	CODIGO Nº PART NO.	DESCRIPCION DESCRIPTION	2DU4	OBSERVACIONES REMARKS
28	4C6-F3181-00	..TORNILLO CABEZAHEXAGONAL ..BOLT, HEXAGON SOCKET HEAD	1	
29	4C6-F3145-00	..RETEN DE ACEITE ..OIL SEAL	1	(KAIFA)
30	4C6-F3157-00	..ANILLO DEL PISTON ..RING, PISTON	1	(KAIFA)
31	5S9-F3141-00	..RESORTE HORQUILLA DELANT. ..SPRING, FRONT FORK	1	
32	4C6-F3147-00	..ARO ..O-RING	1	(KAIFA)
33	4C6-F3113-00	..COLLAR ..COLLAR	1	
34	4C6-F3155-00	..ANILLO DE FIELTRO ..RING, FELT	1	
35	4C6-F3154-00	..TAPON TUBO INTERIOR ..CAP	1	
36	4C6-F3191-00	..FUNDA ..BOOT	1	
37	4C6-F3192-00	..BANDA ..BAND	1	
38	5S9-F3340-00	..PLATINA INFERIOR COMPLETA ..UNDER BRACKET COMP.	1	
39	3KW-F3462-00	..SELLO PARA POLVO ..SEAL, DUST	1	
40	4C6-F3411-10	..PISTA DE BOLAS 1 ..RACE, BALL 1	1	
41	4C6-F3346-00	..PERNO 1 ..BOLT 1	4	
42	4C6-F3153-00	..ANILLO DE ENGANCHE ..RING, SNAP	2	
43	58P-F3317-00	SOSTÉN DE CABLE HOLDER, CABLE	1	
44	9580L-06010	TORNILLO BOLT, FLANGE	1	
45	4C6-F3412-00	PISTA DE BOLAS 2 RACE, BALL 2	1	
46	4C6-F341E-00	RETEN DE COJINETE RETAINER, BALL BEARING	1	
47	4C6-F3414-00	BASE DE BOLA 4 RACE, BALL 4	1	
48	4C6-F3413-00	BASE DE BOLA 3 RACE, BALL 3	1	
49	4C6-F341D-00	RETEN DE COJINETE 2 RETAINER, BALL BEARING 2	1	
50	4C6-F3416-00	CUBIERTA DE BASE DE BOLA 2 COVER, BALL RACE 2	1	
51	90179-25811	TUERCA NUT	3	
52	90202-26142	ARANDELA DE PLANA WASHER, PLATE	1	
53	4VP-F3418-00	ARANDELA ESPECIAL WASHER, SPECIAL	1	
54	41D-F3415-00	CUBIERTA DE PISTA DE BOLAS 1 COVER, BALL RACE 1	1	



**FIG. 18 DEPOSITO DE COMBUSTIBLE FUEL TANK**



58P1261-J180

REF. Nº	CODIGO Nº PART NO.	DESCRIPCION DESCRIPTION	2DU4				OBSERVACIONES REMARKS
1	58P-F4110-00	DEPOSITO DE COMBUSTIBLE COMP. FUEL TANK COMP.	1				
2	5ML-F1541-00	AMORTIGUADOR 1 DAMPER 1	1				
3	24P-XH575-01	MEDIDOR DE COMBUSTIBLE COMPL. SENDER UNIT ASSY	1				
4	53X-H5753-20	.EMPAQUE DE UNIDAD TRANSMISORA .GASKET, SENDER UNIT	1				
5	95827-06012	TORNILLO BOLT, FLANGE	4				
6	90119-05071	TORNILLO CON ARANDELA BOLT, WITH WASHER	4				
7	24P-F4500-01	GRIFO DE COMBUSTIBLE 1 FUEL COCK ASSY 1	1				
8	4CW-F452K-00	.ANILLO O .O-RING	1				
9	90149-06011	TORNILLO DE REGLAJE SCREW	2				
10	90202-05193	ARANDELA DE PLANA WASHER, PLATE	2				
11	5S9-F414A-00	CUBIERTA DE LLENADOR COVER, FILLER	1				
12	4TE-F1753-00	COPA DE CONECTOR BOSS, CONNECTOR	1				
13	91A11-07048	TUBO RESEIRADERO TUBE,FLEXIBLE	1				
14	91A10-07005	TUBO TUBE, FLEXIBLE	1				
15	3UH-F4376-00	TUBO DE UNION 1 PIPE, JOINT 1	1				
16	90467-10041	PRESILLA CLIP	3				
17	24P-F4311-00	TUBO DE COMBUSTIBLE 1 PIPE, FUEL 1	1				
18	90467-09006	PRESILLA CLIP	2				
19	24P-F4316-00	TUBO 6 PIPE 6	1				
20	90467-08003	PRESILLA CLIP	1				
21	90467-09006	PRESILLA CLIP	1				
22	3UH-F4112-10	TUBO JUNTA PIPE	1				
23	90450-28802	BRIDA, MANGUERA HOSE CLAMP ASSY	1				
24	3UH-F1753-00	COPA DE CONECTOR BOSS, CONNECTOR	1				
25	24P-F4313-00	TUBO 3 PIPE 3	1				
26	90467-09006	PRESILLA CLIP	2				
27	91317-05014	PERNO BOLT	3				



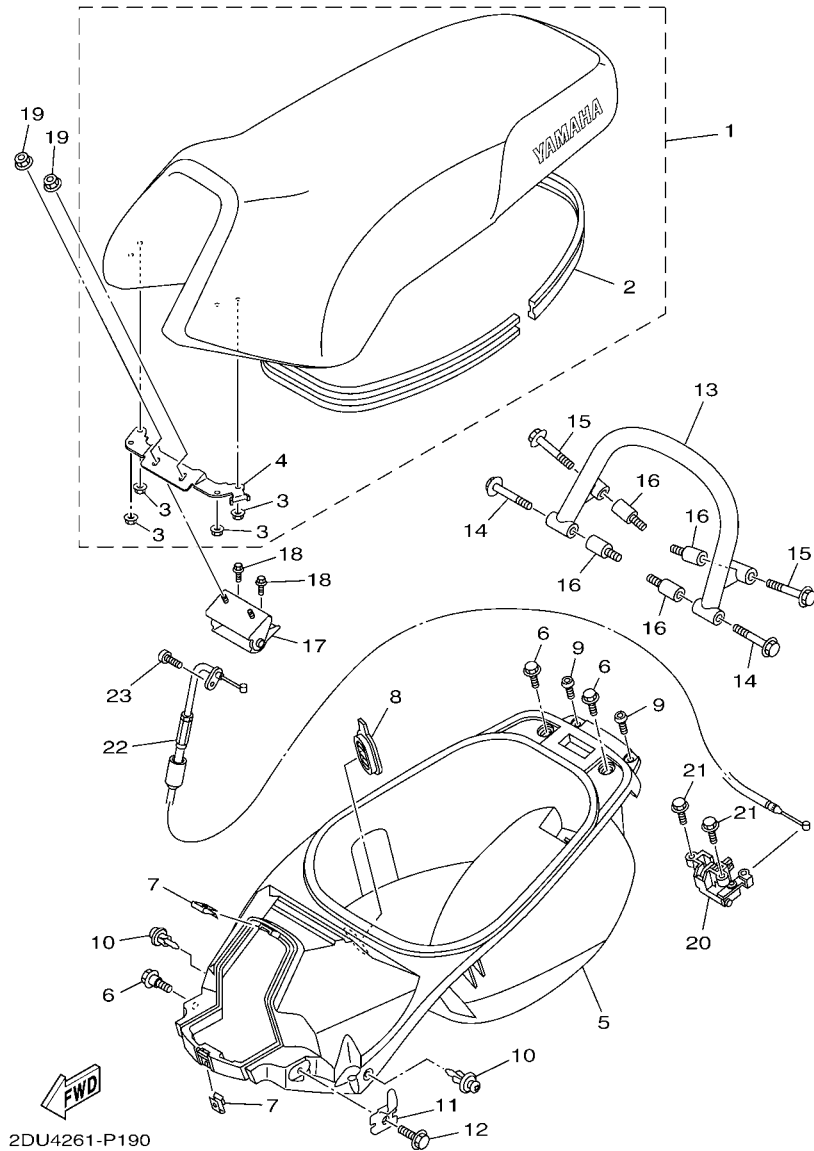
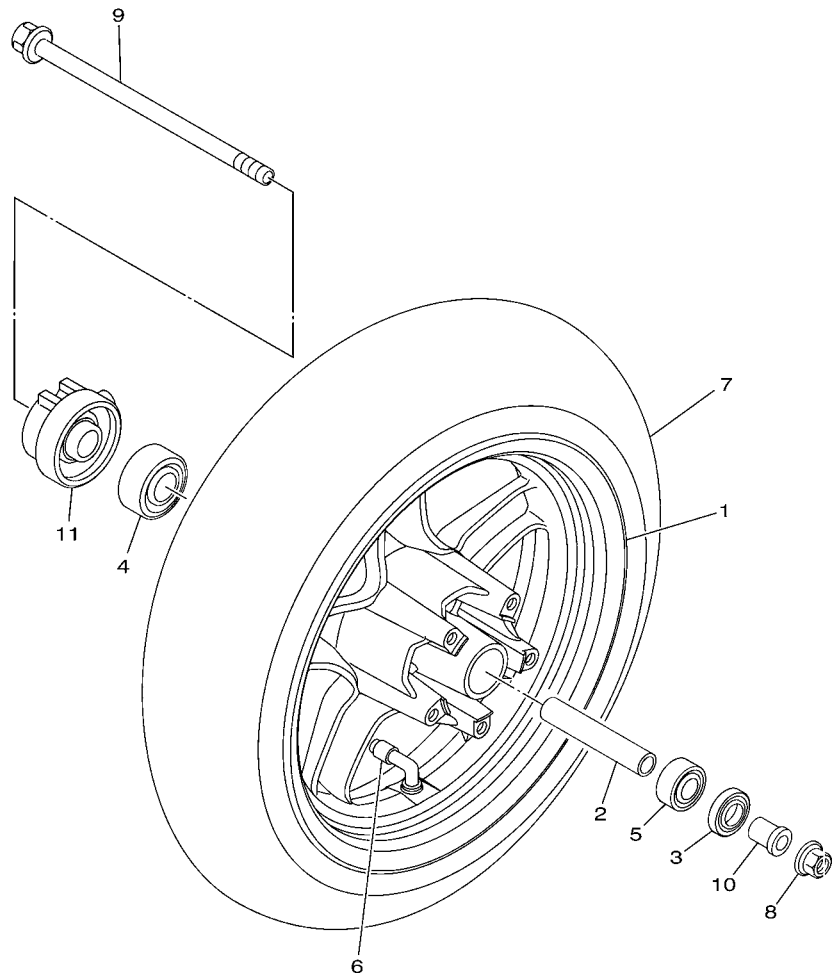


FIG. 19 ASIENTO

SEAT

REF. N°	CODIGO N° PART NO.	DESCRIPCION DESCRIPTION	2DU4				OBSERVACIONES REMARKS
1	58P-F4730-50	SILLIN DOBLE COMPLETO DOUBLE SEAT ASSY	1				
2	5S9-F475M-00	.SELLO .SEAL	1				
3	90179-06635	.TUERCA .NUT	4				
4	58P-F197K-00	.BISAGRA 2 .HINGE 2	1				
5	24P-F473R-00	CAJA 1 BOX 1	1				
6	90109-063F1	PERNO BOLT	3				
7	90183-05807	TUERCA DE RESORTE NUT, SPRING	2				
8	1B6-F4742-00	ANILLO PROTECTOR GROMMET	1				
9	90169-05800	TORNILLO TAPPING SCREW	2				
10	90269-06806	REMACHE RIVET	2				
11	5S9-F1398-00	COLGADOR DE CASCO HANGER, HELMET	1				
12	95807-06016	TORNILLO BOLT, FLANGE	1				
13	2DU-F4812-00-7M	MANIJA HANDLE	1				MDS MDS
14	90119-08848	TORNILLO CON ARANDELA BOLT, WITH WASHER	2				
15	90119-08847	TORNILLO CON ARANDELA BOLT, WITH WASHER	2				
16	5S9-F4735-00	TUERCA FIXADORA SPEED NUT	4				
17	5S9-F4772-00	RESORTE HINGE ASSY	1				
18	95807-06012	TORNILLO BOLT, FLANGE	2				
19	95707-06500	TUERCA DE BRIDA NUT, FLANGE	2				
20	5ML-F4780-00	CERRADURA SILLIN COMPLETO SEAT LOCK ASSY	1				
21	95807-06016	TORNILLO BOLT, FLANGE	2				
22	5S9-F478E-01	CABLE CABLE, SEAT LOCK	1				
23	98507-05010	TORNILLO DE CABEZA CON PLANA SCREW, PAN HEAD	1				

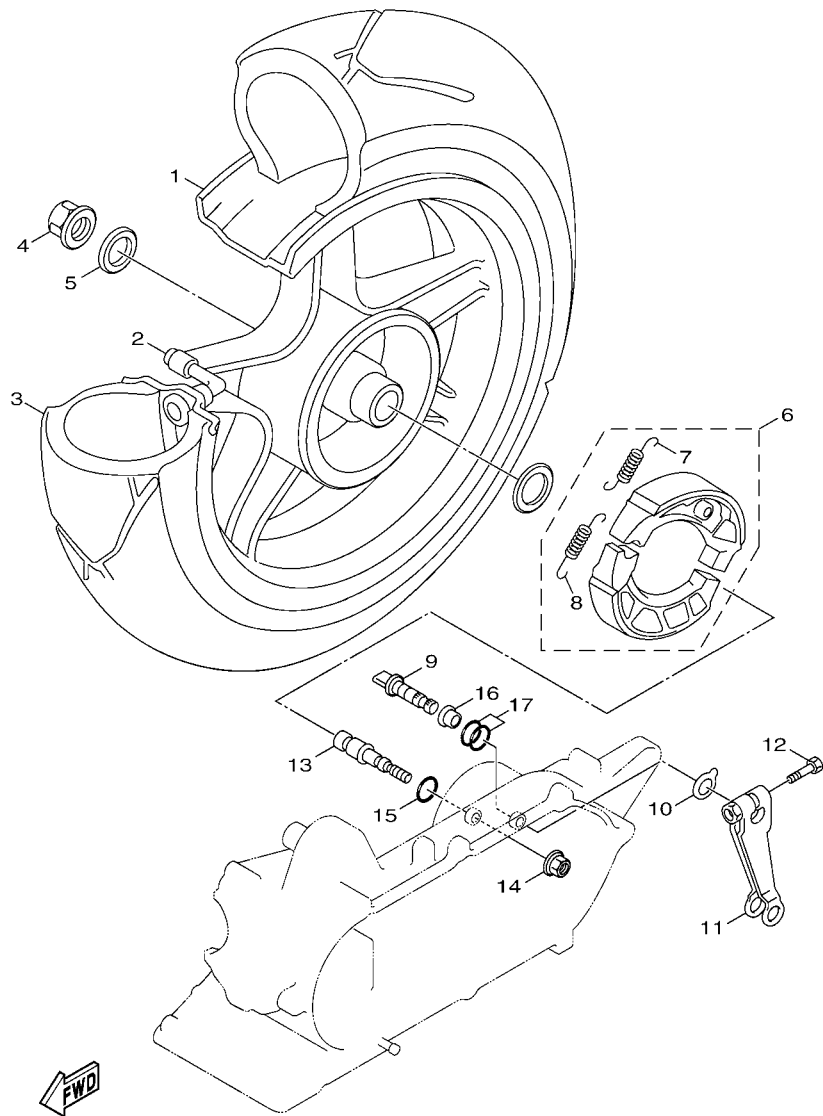


FWD  
2DU3261-N200

FIG. 20 RUEDA DELANTERA FRONT WHEEL

REF. Nº	CODIGO Nº PART NO.	DESCRIPCION DESCRIPTION	2DU4				OBSERVACIONES REMARKS
1	58P-F5168-00-33	RUEDA FUNDIDA DELANTERA CAST WHEEL, FRONT	1				YB(SMX,WM1,MT1) YB(SMX,WM1,MT1)
	58P-F5168-00-35	RUEDA FUNDIDA DELANTERA CAST WHEEL, FRONT	1				SL(VOS2,PRM2) SL(VOS2,PRM2)
2	5ML-F5183-00	COLLAR DE RUEDA COLLAR, WHEEL	1				
3	93106-17805	SELLO ACEITE OIL SEAL	1				
4	93306-201Y7	COJINETE BEARING	1				
5	93306-301YA	COJINETE BEARING	1				
6	93900-00805	VALVULA VALVE, RIM	1				
7	94112-12802	NEUMATICO (120/70-12 51J D303) TIRE(120/70-12 51J D303FA T/L)	1				DUNLOP DUNLOP
8	95607-12200	TUERCA DE AUTO-CIERRE NUT, SELF-LOCKING	1				
9	5S9-F5181-00	EJE DE LA RUEDA AXLE, WHEEL	1				
10	90387-12852	ESPACIADOR COLLAR	1				
11	5S9-F5190-00	UNIDAD DE ENGRANAJE COMPLETA GEAR UNIT ASSY	1				



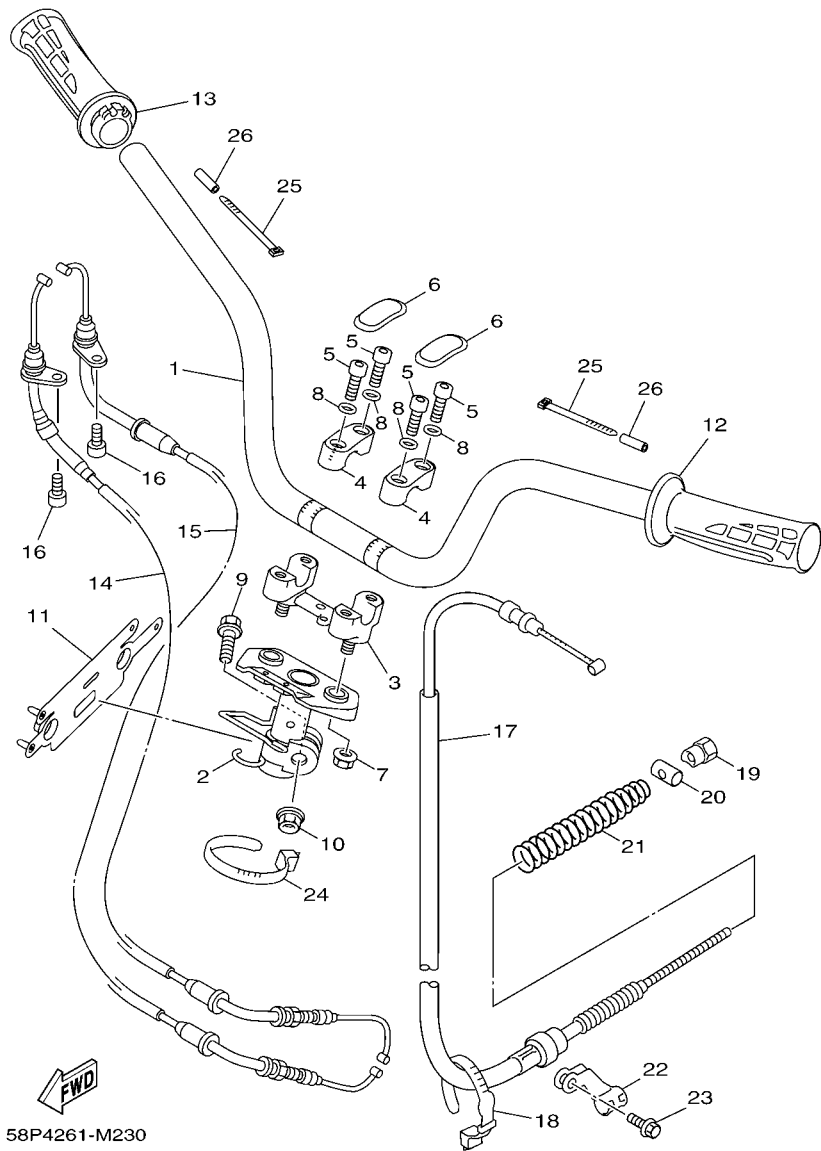


2DU3261-N220

FIG. 22 RUEDA TRASERA

REAR WHEEL

REF. Nº	CODIGO Nº PART NO.	DESCRIPCION DESCRIPTION	2DU4			OBSERVACIONES REMARKS
1	5ML-F5338-21-33	RUEDA FUNDIDA TRASERA CAST WHEEL, REAR	1			YB(SMX,WM1,MT1) YB(SMX,WM1,MT1)
	5ML-F5338-21-35	RUEDA FUNDIDA TRASERA CAST WHEEL, REAR	1			SL(VOS2,PRM2) SL(VOS2,PRM2)
2	93900-00805	VALVULA VALVE, RIM	1			
3	94113-12801	NEUMATICO(130/70-12 59J D303A) TIRE (130/70-12 59J D303A T/L)	1			DUNLOP DUNLOP
4	90185-14124	TUERCA AUTOBLOCANTE NUT, SELF-LOCKING	1			
5	90201-220J8	ARANDELA PLANA WASHER, PLATE	1			
6	5ML-XF533-00	JUEGO DE ZAPATA DE FRENO BRAKE SHOE SET	1			
7	90506-13800	.RESORTE DE TENSION .SPRING, TENSION	1			
8	90506-16802	.RESORTE DE TENSION .SPRING, TENSION	1			
9	5S9-F5351-00	ARBOL DE LEVAS CAMSHAFT	1			
10	4VP-F533A-00	PLACA INDICADOR PLATE, INDICATOR	1			
11	5S9-F5355-00	PALANCA DE ARBOL DE LEVAS LEVER, CAMSHAFT	1			
12	90101-06278	TORNILLO BOLT	1			
13	5ML-F5326-00	PASADOR PIVOTE PIN, PIVOT	1			
14	95707-10500	TUERCA DE BRIDA NUT, FLANGE	1			
15	93210-09859	ANILLO O O-RING	1			
16	5ML-F5377-00	COLLAR DE RUEDA COLLAR, WHEEL	1			
17	93210-14802	ANILLO O O-RING	2			



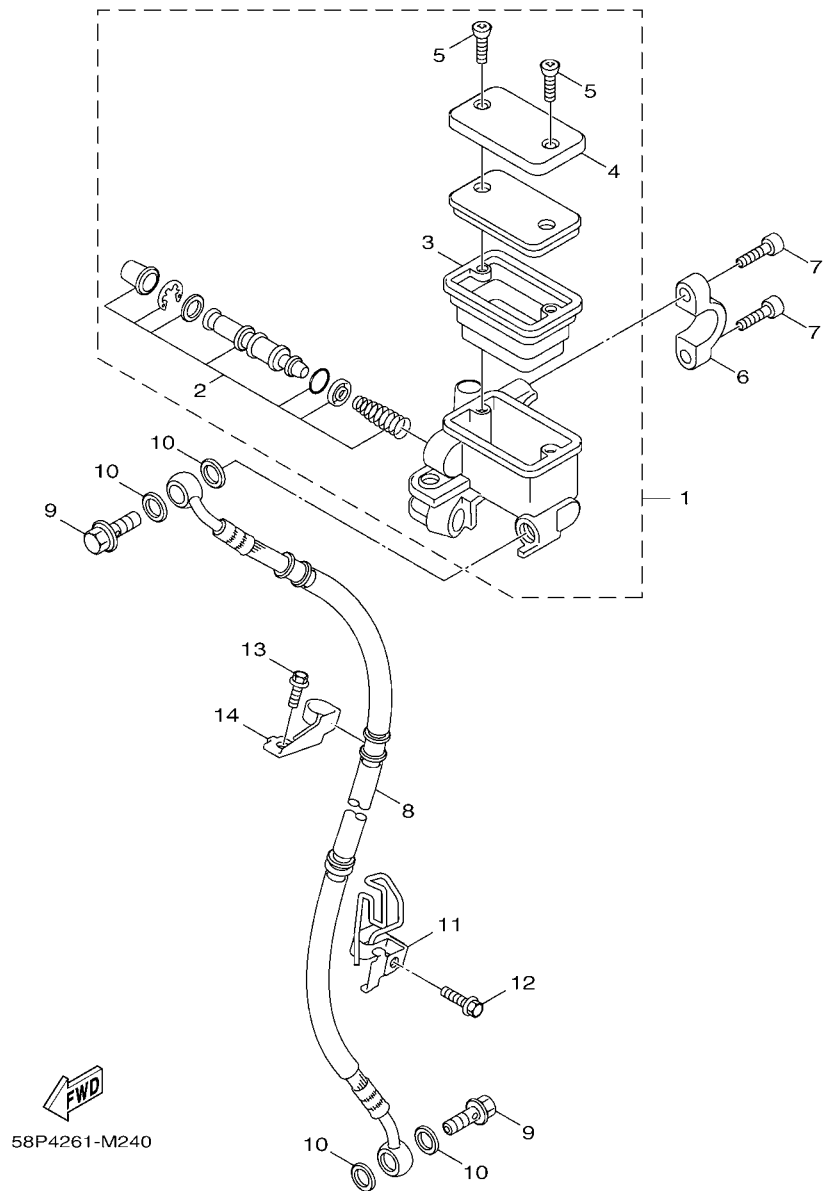
58P4261-M230

FIG. 23 MANILLAR & CABLE

STEERING HANDLE & CABLE

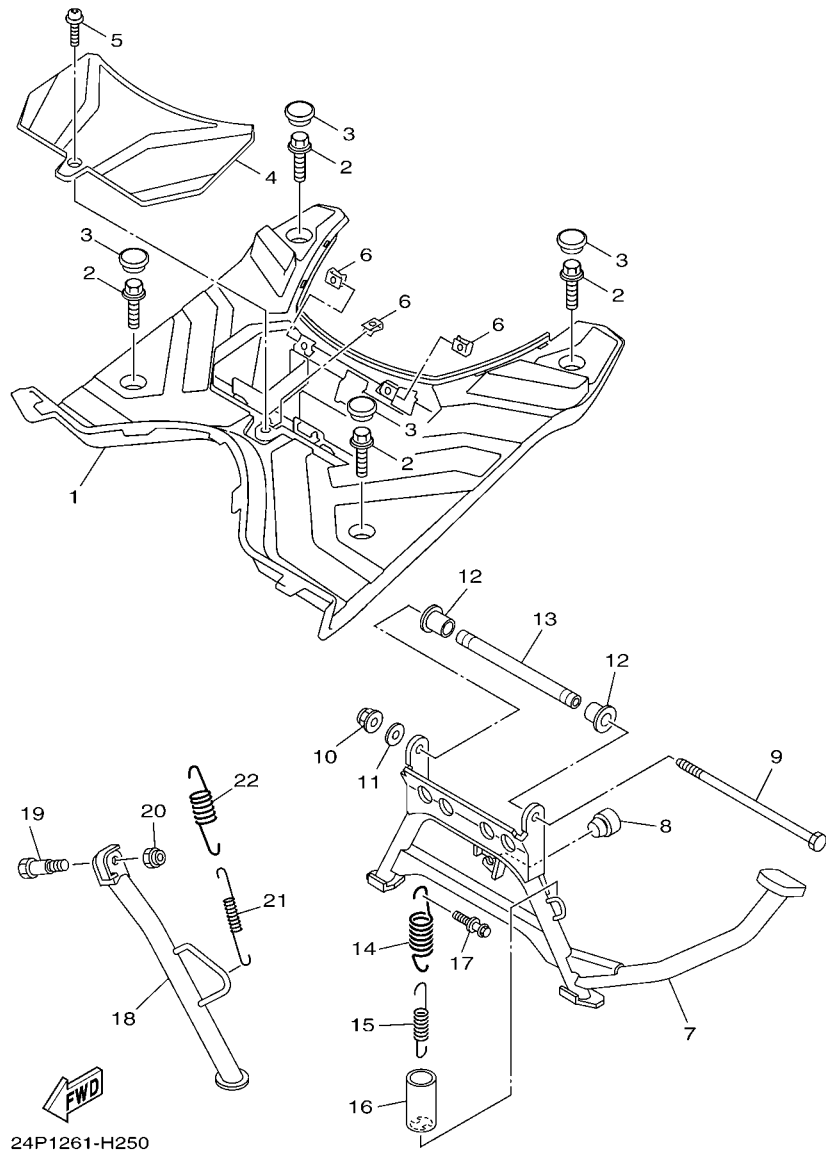
REF. Nº	CODIGO Nº PART NO.	DESCRIPCION DESCRIPTION	2DU4				OBSERVACIONES REMARKS
1	24P-F6111-00	MANUBRIO HANDLEBAR	1				
2	5S9-F3461-02	SOPORTE DE MANUBRIO BRACKET, HANDLE	1				
3	5FH-F3442-00	SOPORTE DE MANUBRIO INFERIOR HOLDER, HANDLE LOWER	1				
4	1MH-F3441-01-35	SOPORTE DE MANUBRIO HOLDER, HANDLE UPPER	2				SL SL
5	91317-08025	PERNO BOLT	4				
6	1MH-F3469-00	TÁPA DE PERNO CAP, BOLT	2				
7	90185-10801	TUERCA AUTOBLOCANTE NUT, SELF-LOCKING	2				
8	90201-08823	ARANDELA PLANA WASHER, PLATE	4				
9	90105-10036	TORNILLO BOLT, FLANGE	1				
10	90185-10801	TUERCA AUTOBLOCANTE NUT, SELF-LOCKING	1				
11	58P-F6124-00	PROTECTOR DE MANUBRIO PROTECTOR, HANDLEBAR	1				
12	24P-F6241-00	EMPUNADURA GRIP	1				
13	24P-F6240-00	EMPUNADURA COMPLETA GRIP ASSY	1				
14	24P-F6311-10	CABLE DE ACELERADOR 1 CABLE, THROTTLE 1	1				
15	24P-F6312-01	CABLE DE ACELERADOR 2 CABLE, THROTTLE 2	1				
16	91317-05010	PERNO BOLT	2				
17	5S9-F6351-11	CABLE DE FRENO CABLE, BRAKE	1				
18	58P-H3936-00	BANDA DE CABLE DE INTERRUPTOR BAND, SWITCH CORD	1				
19	90179-06843	TUERCA NUT	1				
20	90249-12008	PASADOR PIN	1				
21	90501-16801	RESORTE DE COMPRESION SPRING, COMPRESSION	1				
22	5S9-F637H-00	SOSTEN, DE CABLE 2 HOLDER, WIRE 2	1				
23	95827-06012	TORNILLO BOLT, FLANGE	1				
24	90464-12812	BRIDA CLAMP	1				
25	90464-28800	BRIDA CLAMP	2				
26	58P-F117G-00	PROTECTOR PROTECTOR	2				

FIG. 24 CILINDRO MAESTRO DELANTERO FRONT MASTER CYLINDER



REF. N°	CODIGO Nº PART NO.	DESCRIPCION DESCRIPTION	2DU4				OBSERVACIONES REMARKS
1	46P-F5870-00	CILINDRO MAESTRO COMPLETO MASTER CYLINDER SUB ASSY	1				
2	46P-W0041-00	.JUEGO DE CILINDRO MAESTRO .CYLINDER KIT, MASTER	1				
3	5FA-F5854-00	.EMPAQUE, DIAFRAGMA .DIAPHRAGM, RESERVOIR	1				
4	5FA-F5852-10	.TAPA DE TANQUE DE RESERVA .CAP, RESERVOIR	1				
5	98707-04012	.TORNILLO DE CABEZA PLANA .SCREW, FLAT HEAD	2				
6	3GF-F5867-00	SOPORTE DE CILINDRO MAESTRO BRACKET, MASTER CYLINDER	1				
7	91317-06025	PERNO BOLT	2				
8	46P-F5872-10	MANGUERA DE FRENO 1 HOSE, BRAKE 1	1				
9	90401-10805	PERNO DE UNION BOLT, UNION	2				
10	90201-10118	ARANDELA PLANA WASHER, PLATE	4				
11	5S9-F5875-20	SOPORTE DE MANGUERA FRENO 1 HOLDER, BRAKE HOSE 1	1				
12	95807-06012	TORNILLO BOLT, FLANGE	1				
13	95807-06012	TORNILLO BOLT, FLANGE	1				
14	5S9-F5876-00	SOPORTE DE MANGUERA FRENO 2 HOLDER, BRAKE HOSE 2	1				





24P1261-H250

FIG. 25 SOPORTE & APOYAPIE

STAND & FOOTREST

REF. Nº	CODIGO Nº PART NO.	DESCRIPCION DESCRIPTION	2DU4				OBSERVACIONES REMARKS
1	5S9-F7481-00	TABLERO DE APOYAPIE BOARD, FOOTREST	1				
2	90119-06874	TORNILLO CON ARANDELA BOLT, WITH WASHER	4				
3	5HK-F7475-00	TAPA 1 CAP 1	4				
4	5S9-H2129-00	CUBIERTA DE BATERIA COVER, BATTERY	1				
5	97707-50012	TORNILLO SCREW, TRUSS HEAD TAPPING	1				
6	90183-05807	TUERCA DE RESORTE NUT, SPRING	3				
7	24P-F7111-10	PUNTAL PRINCIPAL STAND, MAIN	1				
8	5S9-F7114-01	TOPE DE PUNTAL PRINCIPAL STOPPER, MAIN STAND	1				
9	5ML-F7117-00	PERNO DE PUNTAL PRINCIPAL BOLT, MAIN STAND	1				
10	95604-08200	TUERCA DE AUTO-CIERRE NUT, U FLANGE	1				
11	90201-08810	ARANDELA PLANA WASHER, PLATE	1				
12	5ML-F7121-00	BUJE BUSH	2				
13	5ML-F7113-00	COLLAR DE PUNTAL PRINCIPAL COLLAR, MAIN STAND	1				
14	90506-40800	RESORTE DE TENSION SPRING, TENSION	1				
15	90506-20803	RESORTE DE TENSION SPRING, TENSION	1				
16	5S9-F7244-00	CUBIERTA COVER	1				
17	5SU-F7254-01	GANCHO HOOK	1				
18	24P-F7311-00	PUNTAL LATERAL STAND, SIDE	1				
19	90109-10005	PERNO BOLT	1				
20	90185-10110	TUERCA AUTOBLOCANTE NUT, SELF-LOCKING	1				
21	90506-16801	RESORTE DE TENSION SPRING, TENSION	1				
22	90506-26802	RESORTE DE TENSION SPRING, TENSION	1				

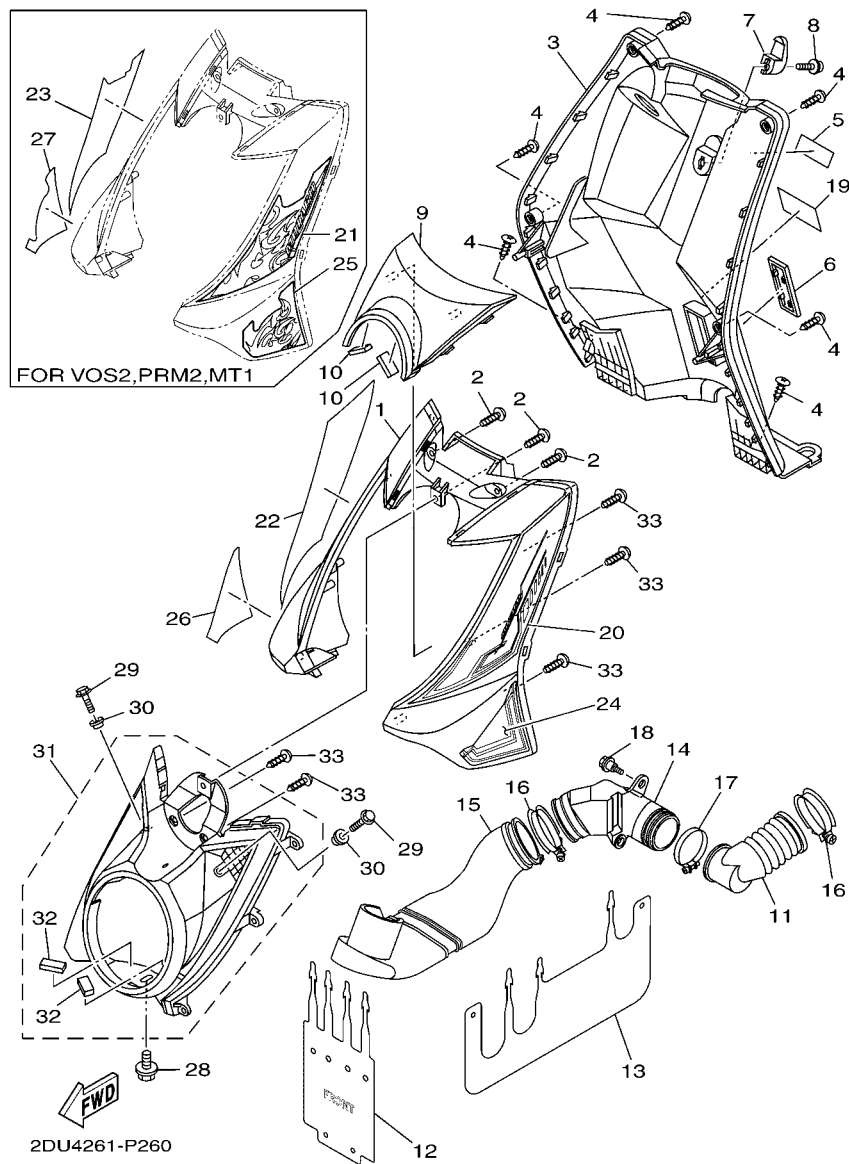


FIG. 26 PATA PROTEGIDA

LEG SHIELD

REF. Nº	CODIGO Nº PART NO.	DESCRIPCION DESCRIPTION	2DU4			OBSERVACIONES REMARKS
1	58P-F8311-10-P1	PROTECCION DE PATA 1 LEG SHIELD 1	1			UR PARA SMX UR FOR SMX
	58P-F8311-10-P0	PROTECCION DE PATA 1 LEG SHIELD 1	1			UR PARA WM1 UR FOR WM1
	58P-F8311-10-P5	PROTECCION DE PATA 1 LEG SHIELD 1	1			UR PARA VOS2 UR FOR VOS2
	58P-F8311-10-P4	PROTECCION DE PATA 1 LEG SHIELD 1	1			UR PARA PRM2 UR FOR PRM2
	58P-F8311-10-P3	PROTECCION DE PATA 1 LEG SHIELD 1	1			UR PARA MT1 UR FOR MT1
2	97707-50016	TORNILLO SCREW, TRUSS HEAD TAPPING	3			
3	5S9-F8312-10	PROTECCION DE PATA 2 LEG SHIELD 2	1			
4	97707-50016	TORNILLO SCREW, TRUSS HEAD TAPPING	6			
5	58P-F1568-00	ETIQUETA DE PRECAUCION LABEL, WARNING	1			
6	5FM-F8349-00	TAPA CAP	1			
7	5S9-F8257-00	GANCHO 1 HOOK 1	1			
8	90159-06822	TORNILLO CON VALONA SCREW, WITH WASHER	1			
9	58P-F8345-00-P9	MOLDURA 1 MOLE 1	1			UR VPBM2(SMX) UR VPBM2(SMX)
	58P-F8345-00-PA	MOLDURA 1 MOLE 1	1			UR MT1(WM1) UR MT1(WM1)
	58P-F8345-00-PB	MOLDURA 1 MOLE 1	1			UR NMM(VOS2,PRM2) UR NMM(VOS2,PRM2)
	58P-F8345-00-PC	MOLDURA 1 MOLE 1	1			UR DNMM(MT1) UR DNMM(MT1)
10	5S9-F8372-00	AMORTIGUADOR DAMPER	2			
11	5ML-F838N-01	CONDUCTO 1 DUCT 1	1			
12	24P-F842N-01	CUBIERTA 2 COVER 2	1			
13	24P-F842M-00	CUBIERTA 1 COVER 1	1			
14	24P-F838R-10	CONDUCTO 2 DUCT 2	1			
15	24P-F838N-10	CONDUCTO 1 DUCT 1	1			
16	5CA-F1823-00	GRAMPA DE MANGUERA CLAMP, HOSE	2			
17	90450-53061	BRIDA, MANGUERA HOSE CLAMP ASSY	1			
18	90109-063F1	PERNO BOLT	2			
19	24P-F1668-10	ETIQUETA DE FRANJA LABEL, TIRE	1			
20	2DU-F832D-00	GRAFICO 17 GRAPHIC 17	1			UR PARA SMX UR FOR SMX

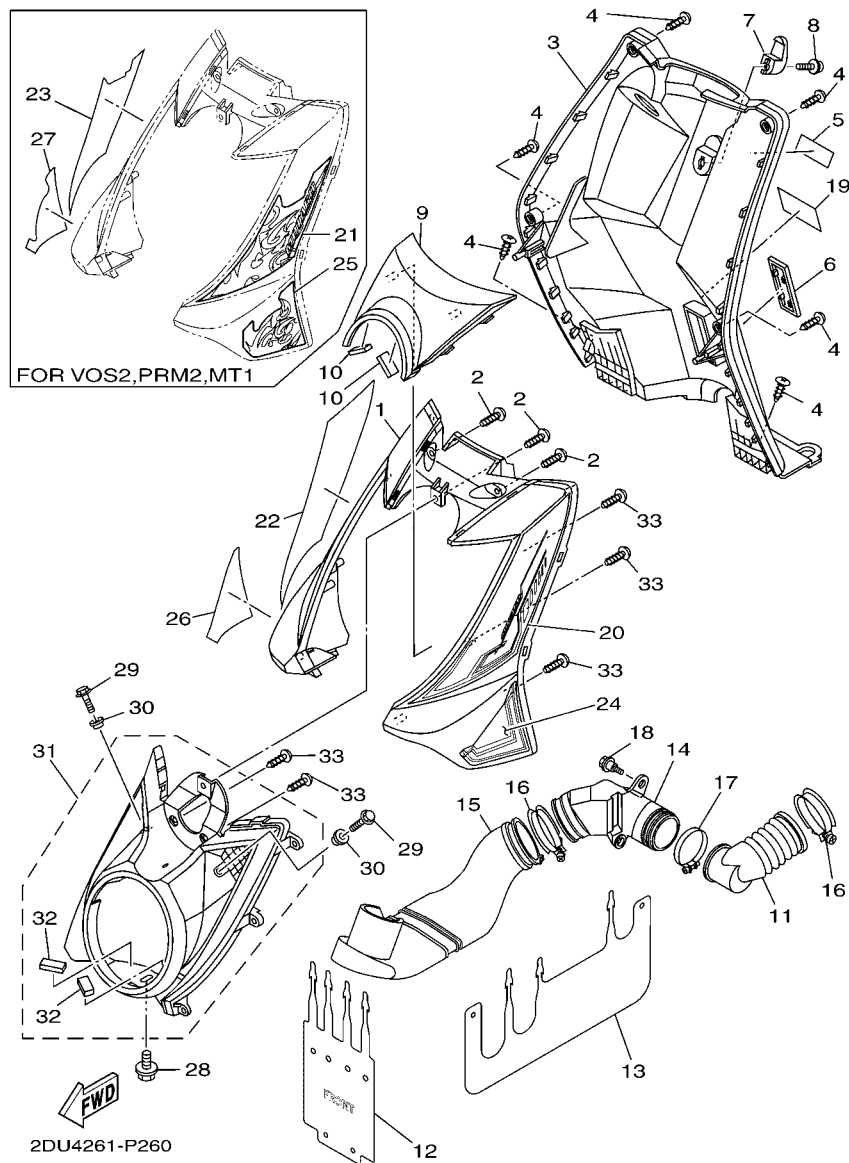


FIG. 26 PATA PROTEGIDA

LEG SHIELD

REF. Nº	CODIGO Nº PART NO.	DESCRIPCION DESCRIPTION	2DU4		OBSERVACIONES REMARKS
20	2DU-F832D-10	GRAFICO 17 GRAPHIC 17	1		UR PARA WM1 UR FOR WM1
21	2DU-F8391-00	CALCOMANIA 1 GRAPHIC 1	1		UR PARA VOS2 UR FOR VOS2
	2DU-F8391-10	CALCOMANIA 1 GRAPHIC 1	1		UR PARA PRM2 UR FOR PRM2
	2DU-F8391-20	CALCOMANIA 1 GRAPHIC 1	1		UR PARA MT1 UR FOR MT1
22	2DU-F832P-00	CALCOMANIA, DE BOVEDA 18 GRAPHIC, 18	1		UR PARA SMX UR FOR SMX
	2DU-F832P-10	CALCOMANIA, DE BOVEDA 18 GRAPHIC, 18	1		UR PARA WM1 UR FOR WM1
23	2DU-F8392-00	CALCOMANIA 2 GRAPHIC 2	1		UR PARA VOS2 UR FOR VOS2
	2DU-F8392-10	CALCOMANIA 2 GRAPHIC 2	1		UR PARA PRM2 UR FOR PRM2
	2DU-F8392-20	CALCOMANIA 2 GRAPHIC 2	1		UR PARA MT1 UR FOR MT1
24	2DU-F8328-00	EMBLEMA EMBLEM	1		UR PARA SMX UR FOR SMX
	2DU-F8328-10	EMBLEMA EMBLEM	1		UR PARA WM1 UR FOR WM1
25	2DU-F8393-00	CALCOMANIA 3 GRAPHIC 3	1		UR PARA VOS2 UR FOR VOS2
	2DU-F8393-10	CALCOMANIA 3 GRAPHIC 3	1		UR PARA PRM2 UR FOR PRM2
	2DU-F8393-20	CALCOMANIA 3 GRAPHIC 3	1		UR PARA MT1 UR FOR MT1
26	2DU-F8338-00	EMBLEMA EMBLEM	1		UR PARA SMX UR FOR SMX
	2DU-F8338-10	EMBLEMA EMBLEM	1		UR PARA WM1 UR FOR WM1
27	2DU-F8394-00	CALCOMANIA 4 GRAPHIC 4	1		UR PARA VOS2 UR FOR VOS2
	2DU-F8394-10	CALCOMANIA 4 GRAPHIC 4	1		UR PARA PRM2 UR FOR PRM2
	2DU-F8394-20	CALCOMANIA 4 GRAPHIC 4	1		UR PARA MT1 UR FOR MT1
28	90119-05004	TORNILLO CON ARANDELA BOLT, WITH WASHER	1		
29	90109-06862	PERNO BOLT	2		
30	90387-068C3	ESPACIADOR COLLAR	2		
31	5S9-XH414-00	CUBIERTA FARO DELANTERO COVER, HEADLIGHT	1		
32	5S9-F8372-00	.AMORTIGUADOR .DAMPER	2		
33	97707-50016	TORNILLO SCREW, TRUSS HEAD TAPPING	8		



1DN1210-K270

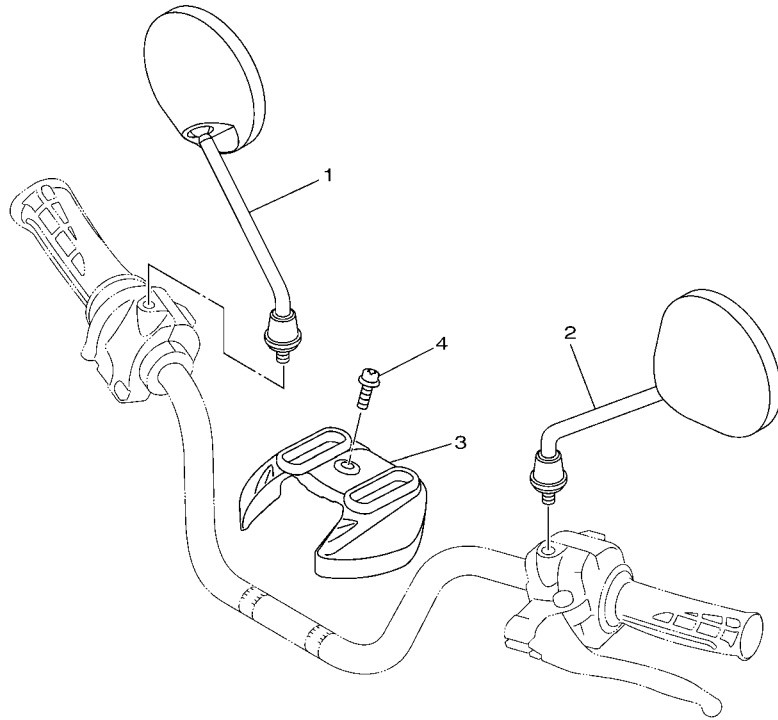


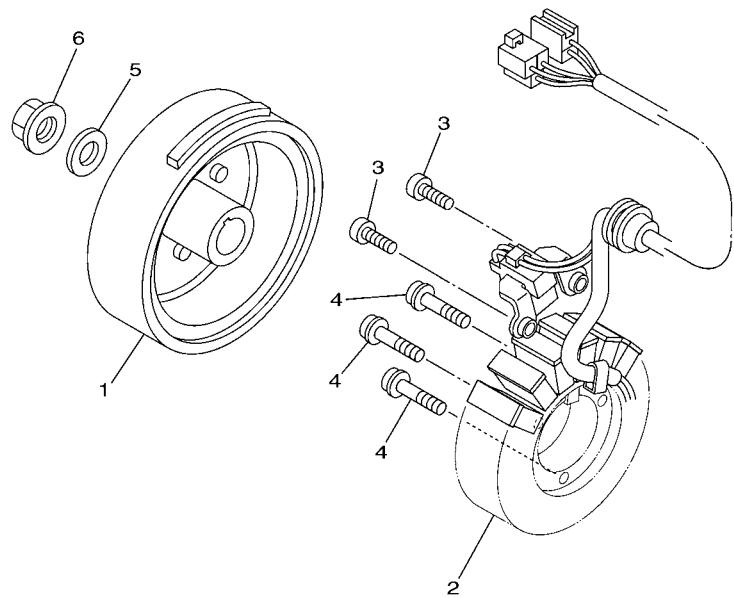
FIG. 27 BOVEDA 1

COWLING 1

REF. Nº	CODIGO Nº PART NO.	DESCRIPCION DESCRIPTION	2DU4				OBSERVACIONES REMARKS
1	4VP-F6290-20	ESPEJO COMPLETO (DERECHO) REAR VIEW MIRROR ASSY (RIGHT)	1				
2	4VP-F6280-20	ESPEJO COMPLETO (IZQUIERDO) REAR VIEW MIRROR ASSY (LEFT)	1				
3	5S9-F6143-01	CUBIERTA DE MANUBRIO SUPERIOR1 COVER, HANDLE UPPER 1	1				
4	90159-05820	TORNILLO CON VALONA SCREW, WITH WASHER	1				
-----							
-----							
-----							
-----							
-----							
-----							
-----							
-----							
-----							
-----							

FIG. 28 GENERADOR

GENERATOR



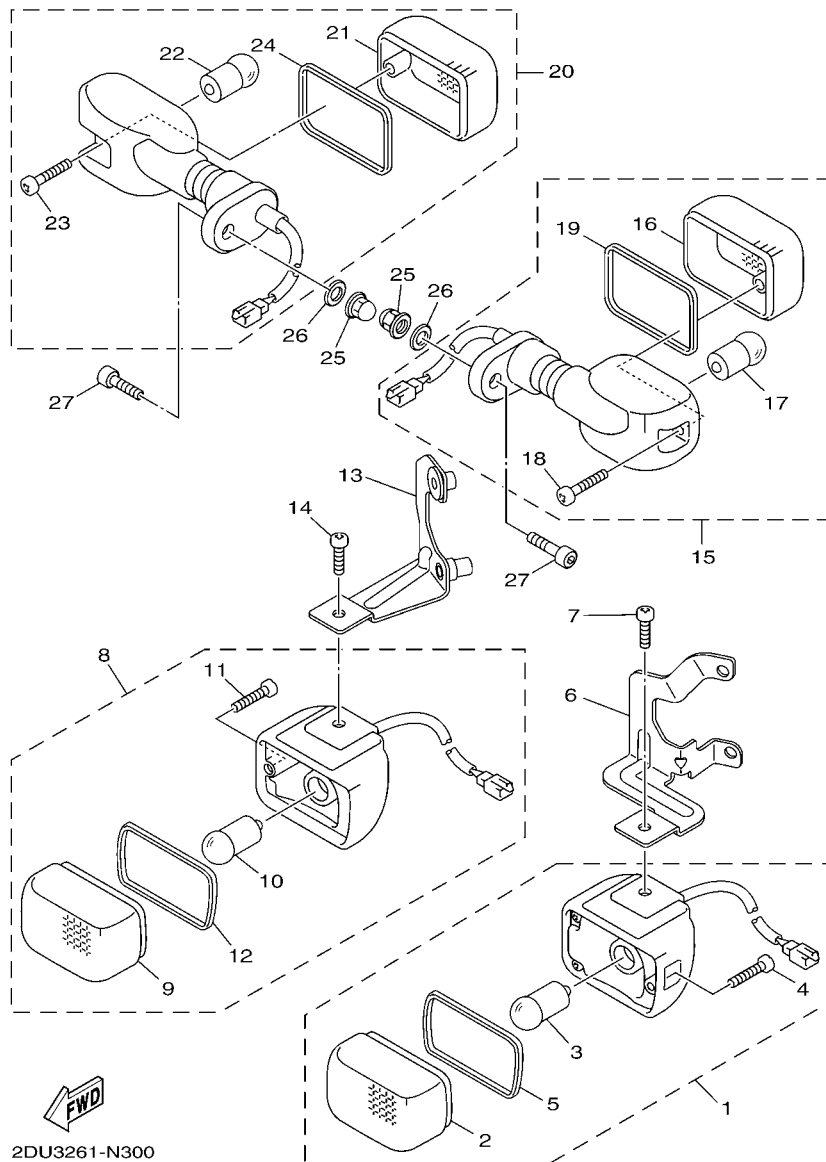
REF. N°	CODIGO N° PART NO.	DESCRIPCION DESCRIPTION	2DU4				OBSERVACIONES REMARKS
1	1P3-H1450-00	ROTOR COMPLETO ROTOR ASSY	1				
2	58P-H1410-00	ESTATOR COMPLETO STATOR ASSY	1				
3	98507-06016	TORNILLO DE CABEZA CON PLANA SCREW, PAN HEAD	2				
4	97607-06225	TORNILLO CAB CON PLANA C/ARAN SCREW, WITH WASHER	3				
5	90201-12688	ARANDELA PLANA WASHER, PLATE	1				
6	90179-12248	TUERCA NUT	1				

  
24S1210-H280



FIG. 30 LUZ DE DESTELLADOR

FLASHER LIGHT



2DU3261-N300

REF. Nº	CODIGO Nº PART NO.	DESCRIPCION DESCRIPTION	2DU4				OBSERVACIONES REMARKS
1	58P-H3310-10	DESTELLADOR DE LUZ DELANT. FRONT FLASHER LIGHT ASSY 1	1				
2	58P-H3312-10	.LENTE DE DESTELLADOR .LENS, FLASHER	1				
3	2DU-H3311-00	.BOMBILLA (12V-10W) .BULB, FLASHER (12V-10W)	1				
4	58P-H3333-00	.TORNILLO ACCESORIO DE LENTE .SCREW, LENS FITTING	1				
5	58P-H3313-00	.EMPAQUE DE LENTE DESTELLADOR .GASKET, FLASHER LENS	1				
6	5S9-H3318-00	SOPORTE DE DESTELLADOR 1 STAY, FLASHER 1	1				
7	92012-05010	PERNO BOLT, BUTTON HEAD	1				
8	58P-H3320-10	DESTELLADOR DE LUZ DELANT. FRONT FLASHER LIGHT ASSY 2	1				
9	58P-H3312-10	.LENTE DE DESTELLADOR .LENS, FLASHER	1				
10	2DU-H3311-00	.BOMBILLA (12V-10W) .BULB, FLASHER (12V-10W)	1				
11	58P-H3333-00	.TORNILLO ACCESORIO DE LENTE .SCREW, LENS FITTING	1				
12	58P-H3313-00	.EMPAQUE DE LENTE DESTELLADOR .GASKET, FLASHER LENS	1				
13	5S9-H3328-00	SOPORTE DE DESTELLADOR 2 STAY, FLASHER 2	1				
14	92012-05010	PERNO BOLT, BUTTON HEAD	1				
15	58P-H3330-10	DESTELLADOR DE LUZ TRAS.COMPL. REAR FLASHER LIGHT ASSY 1	1				
16	58P-H3312-10	.LENTE DE DESTELLADOR .LENS, FLASHER	1				
17	2DU-H3311-00	.BOMBILLA (12V-10W) .BULB, FLASHER (12V-10W)	1				
18	58P-H3333-00	.TORNILLO ACCESORIO DE LENTE .SCREW, LENS FITTING	1				
19	58P-H3313-00	.EMPAQUE DE LENTE DESTELLADOR .GASKET, FLASHER LENS	1				
20	58P-H3340-10	DESTELLADOR DE LUZ TRAS.COMPL. REAR FLASHER LIGHT ASSY 2	1				
21	58P-H3312-10	.LENTE DE DESTELLADOR .LENS, FLASHER	1				
22	2DU-H3311-00	.BOMBILLA (12V-10W) .BULB, FLASHER (12V-10W)	1				
23	58P-H3333-00	.TORNILLO ACCESORIO DE LENTE .SCREW, LENS FITTING	1				
24	58P-H3313-00	.EMPAQUE DE LENTE DESTELLADOR .GASKET, FLASHER LENS	1				
25	90176-06055	TUERCA CORONA NUT, CROWN	2				
26	90201-06557	ARANDELA PLANA WASHER, PLATE	2				
27	90110-06852	TORNILLO ALLEN BOLT, HEXAGON SOCKET HEAD	2				





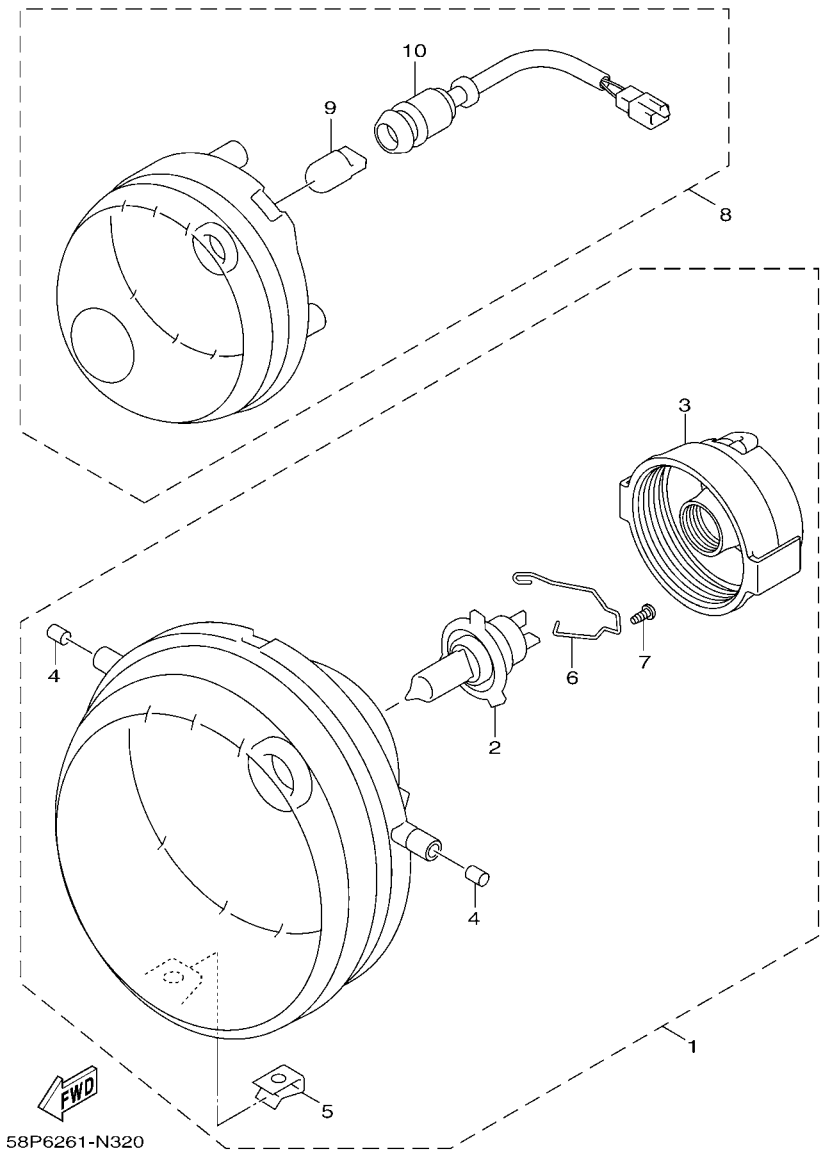


FIG. 32 FARO DELANTERO

HEADLIGHT

REF. N°	CODIGO N° PART NO.	DESCRIPCION DESCRIPTION	2DU4				OBSERVACIONES REMARKS
1	58P-H4310-00	UNIDAD DE FARO DELANTERO COMPL HEADLIGHT UNIT ASSY	1				
2	58P-H4314-00	.BOMBILLA (12V-35/35W) .BULB, HEADLIGHT (12V-35/35W)	1				
3	58P-H4378-00	.TAPA .CAP	1				
4	58P-H4345-00	.AMORT DE FARO DELANTERO .DAMPER, HEADLIGHT	2				
5	58P-H4334-00	.TUERCA DE AJUSTE .NUT, ADJUSTING	1				
6	58P-H4335-00	.RESORTE .SPRING	1				
7	58P-H4332-00	.RESORTE DE TORNILLO .SPRING, SCREW	1				
8	5S9-H4301-01	LUZ PILOTO COMPLETA 1 PILOT LIGHT ASSY 1	1				
9	5FM-H4347-00	.BOMBILLA (12V-5W) .BULB (12V-5W)	1				
10	5S9-H4312-00	.CABLE COMPLETA .CORD ASSY	1				

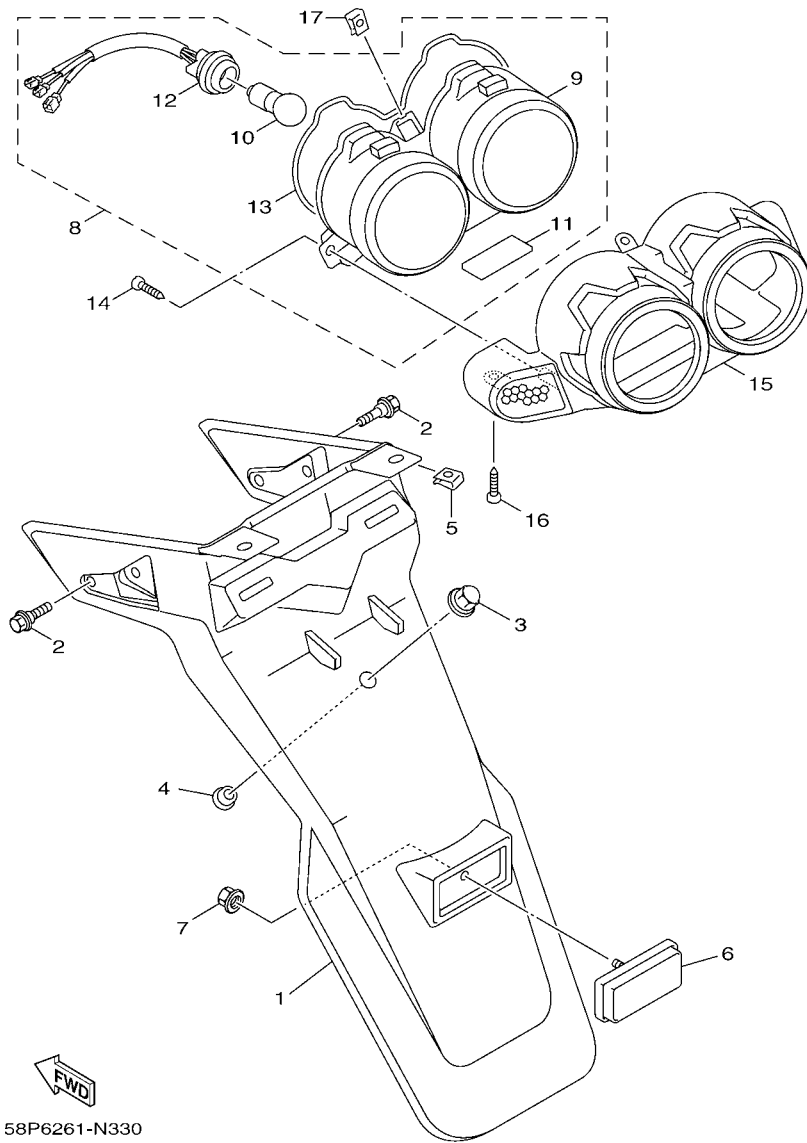
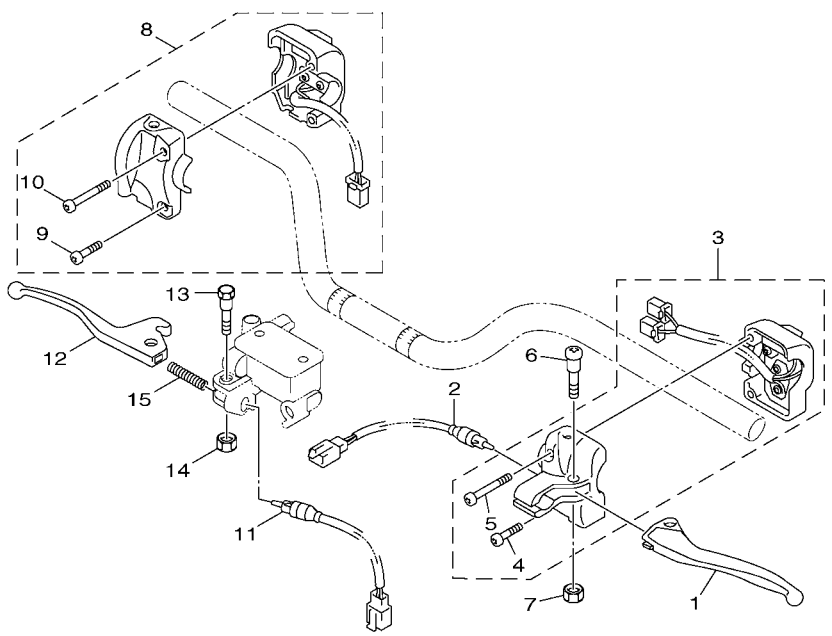


FIG. 33 LUZ DE COLA

TAILLIGHT

REF. N°	CODIGO N° PART NO.	DESCRIPCION DESCRIPTION	2DU4				OBSERVACIONES REMARKS
1	5S9-F1685-01	SOPORTE DE LICENCIA BRACKET, LICENSE	1				
2	90109-06043	PERNO BOLT	2				
3	90176-06065	TUERCA CORONA NUT, CROWN	1				
4	90387-06868	ESPACIADOR COLLAR	1				
5	90183-05807	TUERCA DE RESORTE NUT, SPRING	2				
6	3KW-H5130-00	REFLECTOR TRASERO COMPLETO REAR REFLECTOR ASSY	1				
7	95707-05300	TUERCA DE BRIDA NUT, FLANGE	1				
8	58P-H4700-00	FARO TRASERO COMPLET. TAILLIGHT ASSY	1				
9	58P-H4721-00	.LENTE DE FARO TRASERO .LENS, TAILLIGHT	1				
10	58P-H4714-00	.BOMBILLA (12V-P21/5W) .BULB (12V-P21/5W)	1				
11	58P-H4743-00	.LENTE DE LUZ DE LICENCIA .LENS, LICENCE LIGHT	1				
12	58P-H473A-00	.CABLE COMPLETA .CORD ASSY	1				
13	58P-H4723-00	.EMPAQUE LENTE FARO TRASERO .GASKET, TAIL LENS	1				
14	97707-50016	TORNILLO SCREW, TRUSS HEAD TAPPING	2				
15	5S9-H4716-01	CUBIERTA DE FARO TRASERO COVER, TAILLIGHT	1				
16	97707-50012	TORNILLO SCREW, TRUSS HEAD TAPPING	2				
17	90183-05807	TUERCA DE RESORTE NUT, SPRING	1				

FIG. 34 INTERRUPTOR DE MANILLAR&PALANC Handle Switch & Lever

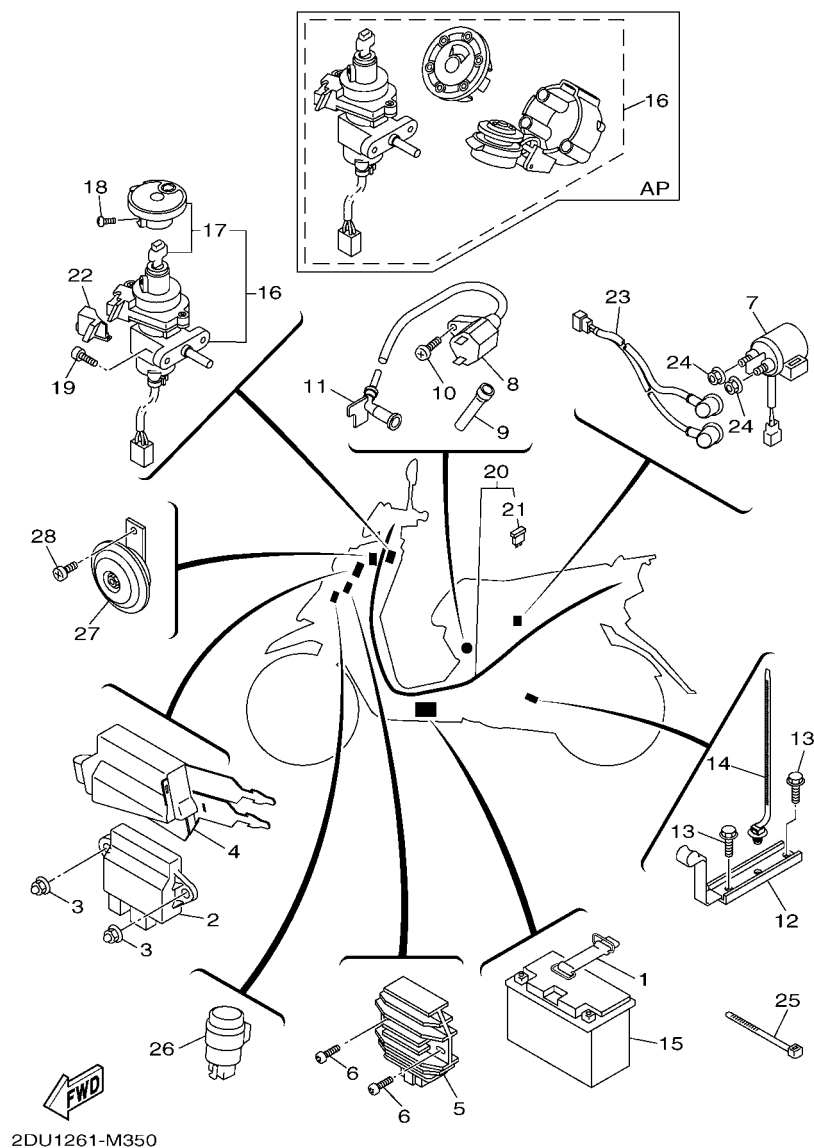


REF. Nº	CODIGO Nº PART NO.	DESCRIPCION DESCRIPTION	2DU4				OBSERVACIONES REMARKS
1	58P-H3912-00	PALANCA 1 LEVER 1	1				
2	5S9-H3980-40	INTERRUPT. DE PARADA DELANTERO FRONT STOP SWITCH ASSY	1				
3	2DU-H3963-01	INTERRUPTOR DE MANIJA 3 SWITCH, HANDLE 3	1				
4	98517-05020	.TORNILLO DE CABEZA CON PLANA .SCREW, PAN HEAD	1				
5	98517-05030	.TORNILLO DE CABEZA CON PLANA .SCREW, PAN HEAD	1				
6	3XG-H3915-00	TORNILLO ACCESORIO DE PALANCA SCREW, LEVER FITTING	1				
7	95607-05100	TUERCA AUTOBLOCANTE NUT, U	1				
8	1DN-H3976-10	INTERRUPTOR DE MANIJA 1 SWITCH, HANDLE 1	1				
9	98507-05035	.TORNILLO DE CABEZA PLANA .SCREW, PAN HEAD	1				
10	98507-05040	.TORNILLO DE CABEZA PLANA .SCREW, PAN HEAD	1				
11	5S9-H3980-30	INTERRUPT. DE PARADA DELANTERO FRONT STOP SWITCH ASSY	1				
12	58P-H3922-00	PALANCA 2 LEVER 2	1				
13	90109-06577	PERNO BOLT	1				
14	95607-06100	TUERCA AUTOBLOCANTE NUT, U	1				
15	90501-10312	RESORTE DE COMPRESION SPRING, COMPRESSION	1				

  
58P3261-L340

FIG. 35 EQUIPO ELECTRICO 1

ELECTRICAL 1



2DU1261-M350

REF. Nº	CODIGO Nº PART NO.	DESCRIPCION DESCRIPTION	2DU4				OBSERVACIONES REMARKS
1	5S9-H2131-00	TIRANTE DE BATERIA BAND, BATTERY	1				
2	1DN-H5540-10	UNIDAD C.D.I. COMPLETA C.D.I. UNIT ASSY	1				
3	90176-05802	TUERCA CORONA NUT, CROWN	2				
4	58P-F135F-00	CUBIERTA COVER	1				
5	5ML-H1960-00	RECTIFICADOR Y REGULADOR RECTIFIER & REGULATOR ASSY	1				
6	95023-06020	TORNILLO BOLT	2				
7	5S9-H1940-00	CONJUNTO ARRANCADOR RELEVO STARTER RELAY ASSY	1				
8	58P-H2310-00	BOBINA DE ENCENDIDO COMPLETA IGNITION COIL ASSY	1				
9	1CE-H2373-00	SELLO DE CABLE ALTA TENSION SEAL, HIGH TENSION CORD	1				
10	98507-05020	TORNILLO DE CABEZA PLANA SCREW, PAN HEAD	1				
11	1YP-H2370-00	TAPÓN DE BÚJIA COMPLT PLUG CAP ASSY	1				
12	58P-E546C-01	SOPORTE HOLDER	1				
13	97527-06512	PERNO CON ARANDELA BOLT, WITH WASHER	2				
14	90464-30802	BRIDA CLAMP	1				
15	1P3-H2100-10	BATERIA COMPLETA(YUASA YT7B-BS) BATTERY ASSY (YUASA YT7B-BS)	1				
16	1DN-H2501-10	LLAVE DE IGNICIÓN COMPLT MAIN SWITCH STEERING LOCK	1				
	1DN-WH203-10	JUEGO DE LLAVE KEY SET	1				AP AP UR UR UR
17	5S9-WH250-20-A0	.OBTURADOR Y LLAVE EN BLANCO .SHUTTER & BLANK KEY	1				
	5S9-WH250-20-C0	.OBTURADOR Y LLAVE EN BLANCO .SHUTTER & BLANK KEY	1				
18	90119-05004	TORNILLO CON ARANDELA BOLT, WITH WASHER	1				
19	98507-06014	TORNILLO DE CABEZA CON PLANA SCREW, PAN HEAD	2				
20	2DU-H2590-00	CONJUNTO DE CABLES WIRE HARNESS ASSY	1				
21	5ML-H2151-10	.FUSIBLE (15A) .FUSE (15A)	2				
22	3D0-H2155-00	BANDA BAND	1				
23	5S9-H2541-00	CABLE CONDUCTOR WIRE, LEAD	1				
24	95307-06700	TUERCA NUT	2				
25	90464-40801	BRIDA CLAMP	1				



INDICE NUMERICO  
NUMERICAL INDEX

CODIGO Nº PART NO.	REF. Nº	CODIGO Nº PART NO.	REF. Nº	CODIGO Nº PART NO.	REF. Nº	CODIGO Nº PART NO.	REF. Nº	CODIGO Nº PART NO.	REF. Nº	CODIGO Nº PART NO.	REF. Nº
5ML-11133-10	1 - 2	5ML-E2231-00	3 - 17	58P-E4467-00	6 - 14	5S9-E5421-02	9 - 18	5ML-F1480-10	13 - 11	2DU-F2210-20	16 - 10
5ML-11134-10	1 - 3	4CW-E2232-00	3 - 26	58P-E446R-00	6 - 24	5S9-E5451-10	9 - 23	3UH-F1481-00	13 - 8	2DU-F2210-30	16 - 10
5ML-12113-00	3 - 4	5ML-E2241-00	3 - 18	58P-E4484-00	6 - 13	5ML-E5453-00	9 - 32	5ML-F1481-00	13 - 16	4X6-F2216-00	9 - 2
663-14159-00	7 - 16	5TY-E2611-00	4 - 9	24P-E4493-20	7 - 33	5ML-E5455-00	9 - 27	5S9-F1482-00	13 - 12		16 - 9
4JH-14160-00	7 - 12	5S9-E262H-00	4 - 16	5S9-E4590-00	7 - 15	5S9-E5461-00	9 - 19	58P-F1511-01	14 - 1	2DU-F2220-20	16 - 11
3TJ-14191-40	7 - 23	5ML-E2651-00	4 - 1	5ML-E4592-00	7 - 26	58P-E546C-01	35 - 12	5ML-F151B-00	14 - 5	2DU-F2220-30	16 - 11
5JG-14531-00	7 - 32	5ML-E2652-00	4 - 4	58P-E4610-10	8 - 1	5ML-E5472-00	9 - 44	5ML-F1541-00	13 - 2	46P-F3100-00	17 - 1
3TJ-14536-40	7 - 24	5ML-E2653-01	4 - 11	5JS-E4617-00	8 - 10	4DM-E5481-00	9 - 47		18 - 2	46P-F3102-00	17 - 2
3TJ-14562-40	7 - 14	5ML-E2658-00	4 - 6	1CE-E4628-00	8 - 15	5CA-E5521-00	10 - 7	5ML-F1544-01	13 - 14	46P-F3103-00	17 - 20
3TJ-14564-40	7 - 43	5ML-E2659-00	4 - 7	1CE-E4708-00	8 - 5	5S9-E5524-00	10 - 1	5S9-F1552-02	14 - 4	5S9-F3110-00	17 - 4
688-14592-00	7 - 19	5ML-E2668-00	4 - 2	5ML-E4737-10	8 - 4	5S9-E5532-00	10 - 9	58P-F1568-00	26 - 5		17 - 22
4DH-14613-00	8 - 18	58P-E2682-00	4 - 14	5JS-E4759-00	8 - 9	5LW-E5538-00	10 - 3	58P-F162H-00	13 - 35	4C6-F3113-00	17 - 15
5BE-14937-00	7 - 40	1P3-E3300-00	5 - 1	4CW-E4766-00	8 - 6	5TY-E5570-01	10 - 4	5CA-F1639-00	14 - 9		17 - 33
3TJ-14952-40	7 - 13	1P3-E3318-00	5 - 3	5JS-E4779-00	8 - 7	5ML-E5601-01	10 - 13	24P-F1668-10	26 - 19	46P-F3126-00	17 - 3
24P-E1102-00	1 - 1	5ML-E3324-00	2 - 8	5ML-E4854-00	7 - 34	5ML-E5620-00	10 - 18	5S9-F1685-01	33 - 1	46P-F3136-00	17 - 21
5ML-E111F-00	3 - 22	1P3-E3325-00	5 - 2	5TY-E4871-00	7 - 36	5TY-E5645-00	10 - 11	5S9-F1711-00	15 - 1	5S9-F3141-00	17 - 13
5ML-E1145-00	3 - 14	1P3-E3362-00	5 - 4	24P-E4901-20	7 - 1	5S9-E5650-00	10 - 5	5S9-F171E-00	15 - 9		17 - 31
4CW-E1155-00	1 - 13	1P3-E3364-00	5 - 5	24P-E4916-20	7 - 3	5ML-E5657-00	11 - 11	58P-F1721-00-P1	15 - 6	5S9-F3142-00	17 - 5
5ML-E1160-00	1 - 9	5ST-E3365-00	5 - 6	5TY-E4922-00	7 - 31	5ML-E5659-00	10 - 20	58P-F1721-00-P3	15 - 6		17 - 23
5ML-E1165-00	1 - 11	5ML-E3411-00	5 - 10	5UA-E4926-00	7 - 28	5ML-E5670-00	10 - 21	58P-F1721-00-P4	15 - 6	4C6-F3145-00	17 - 11
5ML-E1181-00	1 - 21	5ML-E3416-00	9 - 13	24P-E4933-00	7 - 5	5ML-E5673-00	10 - 22	58P-F1721-00-PA	15 - 6		17 - 29
5ML-E1185-00	1 - 10	5ML-E3452-00	2 - 6	5ML-E4935-00	7 - 42	5CA-E6111-01	11 - 1	58P-F1721-00-PB	15 - 6	4C6-F3147-00	17 - 14
5ML-E1186-00	1 - 16	5ML-E3474-00	6 - 7	5TY-E4936-00	7 - 4	4CW-E6611-00	11 - 32	58P-F1731-00-P1	15 - 7		17 - 32
5ML-E1311-20	1 - 25	5ML-E3475-00	5 - 7	24P-E4940-00	7 - 2	1P5-E6620-10	11 - 24	58P-F1731-00-P3	15 - 7	4C6-F3151-00	17 - 7
5ML-E1351-20	1 - 26	5ML-E3556-20	6 - 4	24P-E4943-78	7 - 9	1P5-E6626-00	11 - 25	58P-F1731-00-P4	15 - 7		17 - 25
5ML-E1391-00	1 - 30	3KW-E3569-00	4 - 3	5ML-E4945-00	7 - 35	5S9-E7211-00	12 - 6	58P-F1731-00-PB	15 - 7	4C6-F3153-00	17 - 42
5ML-E1392-00	1 - 31	5ML-E3575-00	6 - 25	5TY-E4947-00	7 - 7	5S9-E7410-00	12 - 1	58P-F1731-00-PC	15 - 7	4C6-F3154-00	17 - 17
5S9-E1400-01	2 - 1	24P-E3585-01	6 - 1	24P-E4948-00	7 - 10	5S9-E7421-00	12 - 5	46P-F173B-00	15 - 17		17 - 35
1P3-E1422-00	2 - 5	5ML-E3595-00	6 - 3	5ML-E4958-00	7 - 25	4HP-E7611-00	11 - 15	46P-F173B-10	15 - 17	4C6-F3155-00	17 - 16
58P-E1603-01	2 - 13	5ML-E3769-00	9 - 39	5TY-E4958-00	7 - 6	5ML-E7620-02	11 - 5	5S9-F1741-00	15 - 8		17 - 34
58P-E1631-00	2 - 10	24P-E414G-00	7 - 8	5TY-E4967-00	7 - 37	5ML-E7623-00	11 - 8	46P-F174B-00	15 - 18	4C6-F3157-00	17 - 12
5LW-E1633-00	2 - 11	1CD-E4169-00	6 - 27	5ML-E4969-00	7 - 27	24P-E7632-00	11 - 7	46P-F174B-10	15 - 18		17 - 30
5LW-E1651-01	2 - 4	24P-E4196-00	7 - 39	24P-E4980-00	7 - 20	5S9-E7641-00	11 - 14	3UH-F1753-00	18 - 24	4C6-F3158-00	17 - 9
5ML-E1681-00	2 - 2	5TY-E4197-20	7 - 38	5TY-E4984-00	7 - 21	5TY-E7644-01	11 - 23	4TE-F1753-00	18 - 12		17 - 27
4C6-E2111-00	3 - 1	24P-E4211-00	7 - 11	5TY-E4985-00	7 - 17	4CW-E7653-00	11 - 9	2DU-F1781-00	15 - 13	4C6-F3171-00	17 - 8
4C6-E2117-00	3 - 6	5TY-E4245-00	7 - 29	58P-E4987-00	1 - 27	4CW-E7660-20	11 - 17	2DU-F1781-10	15 - 13		17 - 26
5WG-E2118-00	3 - 5	5TY-E4245-10	7 - 30	5TY-E4994-00	7 - 41	4CW-E7664-00	11 - 21	2DU-F1782-00	15 - 15	4C6-F3181-00	17 - 10
5ML-E2119-00	3 - 3	24P-E4251-00	6 - 2	5ML-E5113-00	9 - 37	5S9-E7670-10	11 - 18	2DU-F1782-10	15 - 15		17 - 28
4C6-E2121-00	3 - 2	5ML-E4386-00	7 - 18	5ML-E5138-00	9 - 4	58P-F110F-00	13 - 27	2DU-F1783-00	15 - 14	4C6-F318X-00	17 - 6
1P3-E2151-00	3 - 7	58P-E4410-00	6 - 8	5ML-E5191-00	9 - 26	58P-F110G-01	13 - 30	2DU-F1783-10	15 - 14		17 - 24
5HK-E2156-00	3 - 11	58P-E4422-00	6 - 20	5ML-E5351-20	5 - 9	58P-F1110-10-7M	13 - 1	2DU-F1783-20	15 - 14	4C6-F3191-00	17 - 18
3B3-E2157-00	3 - 25	58P-E442G-00	6 - 16	5S9-E5362-00	9 - 38	58P-F1110-10-P0	13 - 1	2DU-F1784-00	15 - 16		17 - 36
5FM-E2159-00	3 - 9	58P-E443E-00	6 - 10	4Y4-E5363-00	9 - 16	58P-F1110-10-P1	13 - 1	2DU-F1784-10	15 - 16	4C6-F3192-00	17 - 19
1P3-E2161-00	3 - 8	5JS-E4445-00	8 - 8	5CA-E5371-00	9 - 5	58P-F117G-00	23 - 26	2DU-F1784-20	15 - 16		17 - 37
5S9-E2170-01	3 - 12	5HK-E4451-00	6 - 18	5ML-E5404-00	9 - 41	2DU-F128A-00	13 - 21	58P-F1823-00	13 - 31	58P-F3317-00	17 - 43
5LW-E2176-00	3 - 13	58P-E4452-00	6 - 17	5ML-E5407-00	9 - 40	58P-F135F-00	35 - 4	5CA-F1823-00	26 - 16	5S9-F3340-00	17 - 38
5ML-E2210-00	3 - 19	58P-E4461-00	6 - 19	24P-E5411-01	9 - 22	5S9-F1398-00	19 - 11	58P-F197K-00	19 - 4	4C6-F3346-00	17 - 41
4DH-E2213-01	3 - 20	58P-E4462-00	6 - 12	5ML-E5417-00	9 - 29	5S9-F1420-00	13 - 6	46P-F2171-10	16 - 1	4C6-F3411-10	17 - 40

INDICE NUMERICO  
NUMERICAL INDEX

CODIGO Nº PART NO.	REF. Nº	CODIGO Nº PART NO.	REF. Nº	CODIGO Nº PART NO.	REF. Nº	CODIGO Nº PART NO.	REF. Nº	CODIGO Nº PART NO.	REF. Nº	CODIGO Nº PART NO.	REF. Nº
4C6-F3412-00	17 - 45	5FA-F5854-00	24 - 3	58P-F8345-00-P9	26 - 9	2DU-H3311-00	30 - 17	58P-H4721-00	33 - 9	90119-05071	18 - 6
4C6-F3413-00	17 - 48	3GF-F5867-00	24 - 6	58P-F8345-00-PA	26 - 9		30 - 22	58P-H4723-00	33 - 13	90119-06096	13 - 29
4C6-F3414-00	17 - 47	46P-F5870-00	24 - 1	58P-F8345-00-PB	26 - 9	58P-H3312-10	30 - 2	58P-H473A-00	33 - 12	90119-06821	14 - 2
41D-F3415-00	17 - 54	46P-F5872-10	24 - 8	58P-F8345-00-PC	26 - 9		30 - 9	58P-H4743-00	33 - 11		14 - 6
4C6-F3416-00	17 - 50	5S9-F5875-20	24 - 11	5FM-F8349-00	26 - 6		30 - 16	3KW-H5130-00	33 - 6	90119-06857	4 - 10
4VP-F3418-00	17 - 53	5S9-F5876-00	24 - 14	5S9-F8372-00	26 - 10		30 - 21	1DN-H5540-10	35 - 2	90119-06874	25 - 2
4C6-F341D-00	17 - 49	4C6-F5919-01	21 - 9		26 - 32	58P-H3313-00	30 - 5	53X-H5753-20	18 - 4	90119-08847	19 - 15
4C6-F341E-00	17 - 46	4C6-F5924-10	21 - 7	5ML-F838N-01	26 - 11		30 - 12	46P-W0041-00	24 - 2	90119-08848	19 - 14
1MH-F3441-01-35	23 - 4	24P-F6111-00	23 - 1	24P-F838N-10	26 - 15		30 - 19	17C-W0045-00	21 - 8	90149-06011	18 - 9
5FH-F3442-00	23 - 3	58P-F6124-00	23 - 11	24P-F838R-10	26 - 14		30 - 24	5NW-W0047-00	21 - 5	90149-08814	21 - 2
5S9-F3461-02	23 - 2	5S9-F6143-01	27 - 3	2DU-F8391-00	26 - 21	5S9-H3318-00	30 - 6	5AG-W0048-00	21 - 6	90153-06803	1 - 6
3KW-F3462-00	17 - 39	58P-F6199-00	13 - 32	2DU-F8391-10	26 - 21	58P-H3320-10	30 - 8	5NW-W0057-00	21 - 4	90154-06826	9 - 43
1MH-F3469-00	23 - 6	4DH-F6199-01	15 - 4	2DU-F8391-20	26 - 21	5S9-H3328-00	30 - 13	58P-WE441-00	6 - 9	90154-06827	6 - 22
58P-F4110-00	18 - 1	5SU-F622F-00	13 - 5	2DU-F8392-00	26 - 23	58P-H3330-10	30 - 15	58P-WE442-00	6 - 15		9 - 46
3UH-F4112-10	18 - 22	24P-F6240-00	23 - 13	2DU-F8392-10	26 - 23	58P-H3333-00	30 - 4	5S9-WE511-01	9 - 1	90159-05820	27 - 4
5S9-F414A-00	18 - 11	24P-F6241-00	23 - 12	2DU-F8392-20	26 - 23		30 - 11	5S9-WE512-00	9 - 3	90159-06812	15 - 3
24P-F4311-00	18 - 17	4VP-F6280-20	27 - 2	2DU-F8393-00	26 - 25		30 - 18	1DN-WH203-10	35 - 16	90159-06822	26 - 8
24P-F4313-00	18 - 25	4VP-F6290-20	27 - 1	2DU-F8393-10	26 - 25		30 - 23	5S9-WH250-20-A0	35 - 17	90169-05800	19 - 9
24P-F4316-00	18 - 19	24P-F6311-10	23 - 14	2DU-F8393-20	26 - 25	58P-H3340-10	30 - 20	5S9-WH250-20-C0	35 - 17	90170-05800	3 - 10
3UH-F4376-00	18 - 15	24P-F6312-01	23 - 15	2DU-F8394-00	26 - 27	5CP-H3350-00	35 - 26	58P-XE543-00	9 - 45	90170-36279	11 - 26
24P-F4500-01	18 - 7	5S9-F6351-11	23 - 17	2DU-F8394-10	26 - 27	24P-H3371-10	35 - 27	5S9-XF161-00	14 - 8	90176-05802	35 - 3
4CW-F452K-00	18 - 8	5S9-F637H-00	23 - 22	2DU-F8394-20	26 - 27	1DN-H350A-00	31 - 1	5ML-XF533-00	22 - 6	90176-06055	30 - 25
5S9-F4602-02	18 - 28	24P-F7111-10	25 - 7	24P-F842M-00	26 - 13	5ST-H3513-00	31 - 3	5S9-XH414-00	26 - 31	90176-06065	33 - 3
5S9-F467E-00	18 - 29	5ML-F7113-00	25 - 13	24P-F842N-01	26 - 12	46P-H3519-00	31 - 2	24P-XH575-01	18 - 3	90176-08816	1 - 19
58P-F4730-50	19 - 1	5S9-F7114-01	25 - 8	58P-H1410-00	28 - 2	5ST-H354P-00	31 - 5	90101-06278	22 - 12	90179-06635	19 - 3
5S9-F4735-00	19 - 16	5ML-F7117-00	25 - 9	1P3-H1450-00	28 - 1	46P-H3550-20	31 - 6	90101-10875	16 - 13	90179-06843	23 - 19
24P-F473R-00	19 - 5	5ML-F7121-00	25 - 12	5S9-H1800-10	29 - 1	5ST-H3663-00	31 - 4	90105-06806	9 - 36	90179-08804	8 - 19
1B6-F4742-00	19 - 8	5S9-F7244-00	25 - 16	3KW-H1801-00	29 - 3	58P-H3912-00	34 - 1	90105-06807	9 - 35	90179-12248	28 - 6
5S9-F475M-00	19 - 2	5SU-F7254-01	25 - 17	5S9-H1828-00	29 - 5	3XG-H3915-00	34 - 6	90105-06808	9 - 9	90179-14427	11 - 31
5S9-F4772-00	19 - 17	24P-F7311-00	25 - 18	5S9-H183G-10	29 - 7	58P-H3922-00	34 - 12	90105-06809	9 - 34	90179-25811	17 - 51
5ML-F4780-00	19 - 20	5HK-F7475-00	25 - 3	5S9-H1890-00	29 - 2	58P-H3936-00	23 - 18	90105-06810	9 - 10	90183-05807	15 - 11
5S9-F478E-01	19 - 22	5S9-F7481-00	25 - 1	5S9-H1940-00	35 - 7	2DU-H3963-01	34 - 3	90105-06817	9 - 11		19 - 7
2DU-F4812-00-7M	19 - 13	24P-F8100-00	13 - 37	5ML-H1960-00	35 - 5	1DN-H3976-10	34 - 8	90105-06819	9 - 21		25 - 6
58P-F5168-00-33	20 - 1	5S9-F8257-00	26 - 7	1P3-H2100-10	35 - 15	5S9-H3980-30	34 - 11	90105-08835	8 - 22		33 - 5
58P-F5168-00-35	20 - 1	58P-F8311-10-P0	26 - 1	5S9-H2129-00	25 - 4	5S9-H3980-40	34 - 2	90105-08836	16 - 12		33 - 17
5S9-F5181-00	20 - 9	58P-F8311-10-P1	26 - 1	5S9-H2131-00	35 - 1	5S9-H4301-01	32 - 8	90105-10036	23 - 9	90183-06813	13 - 28
5ML-F5183-00	20 - 2	58P-F8311-10-P3	26 - 1	5ML-H2151-10	35 - 21	58P-H4310-00	32 - 1	90105-10638	21 - 10	90185-10110	25 - 20
5S9-F5190-00	20 - 11	58P-F8311-10-P4	26 - 1	3D0-H2155-00	35 - 22	5S9-H4312-00	32 - 10	90109-06043	33 - 2	90185-10801	13 - 9
5ML-F5326-00	22 - 13	58P-F8311-10-P5	26 - 1	58P-H2310-00	35 - 8	58P-H4314-00	32 - 2	90109-063F1	19 - 6		13 - 17
5ML-F5338-21-33	22 - 1	5S9-F8312-10	26 - 3	1YP-H2370-00	35 - 11	58P-H4332-00	32 - 7		26 - 18		23 - 7
5ML-F5338-21-35	22 - 1	2DU-F8328-00	26 - 24	1CE-H2373-00	35 - 9	58P-H4334-00	32 - 5	90109-06577	34 - 13		23 - 10
4VP-F533A-00	22 - 10	2DU-F8328-10	26 - 24	1DN-H2501-10	35 - 16	58P-H4335-00	32 - 6	90109-06862	26 - 29	90185-14124	22 - 4
5S9-F5351-00	22 - 9	2DU-F832D-00	26 - 20	5S9-H2541-00	35 - 23	58P-H4345-00	32 - 4	90109-10005	25 - 19	90201-06055	8 - 11
5S9-F5355-00	22 - 11	2DU-F832D-10	26 - 20	2DU-H2590-00	35 - 20	5FM-H4347-00	32 - 9	90110-06852	30 - 27	90201-064H0	6 - 21
5ML-F5377-00	22 - 16	2DU-F832P-00	26 - 22	4C7-H2594-00	13 - 19	58P-H4378-00	32 - 3	90111-06801	8 - 12	90201-06557	30 - 26
46P-F580T-20	21 - 3	2DU-F832P-10	26 - 22	58P-H3310-10	30 - 1	58P-H4700-00	33 - 8	90116-08806	1 - 5	90201-08609	1 - 18
46P-F582T-00	21 - 1	2DU-F8338-00	26 - 26	2DU-H3311-00	30 - 3	58P-H4714-00	33 - 10	90119-05004	26 - 28	90201-08810	25 - 11
5FA-F5852-10	24 - 4	2DU-F8338-10	26 - 26		30 - 10	5S9-H4716-01	33 - 15		35 - 18	90201-08823	23 - 8

INDICE NUMERICO  
NUMERICAL INDEX

CODIGO Nº PART NO.	REF. Nº	CODIGO Nº PART NO.	REF. Nº	CODIGO Nº PART NO.	REF. Nº	CODIGO Nº PART NO.	REF. Nº	CODIGO Nº PART NO.	REF. Nº	CODIGO Nº PART NO.	REF. Nº
90201-10118	24 - 10	90464-60800	13 - 26	93101-21170	11 - 6	95027-06010	9 - 28	97707-50016	26 - 4		
90201-101J1	8 - 20	90467-08003	18 - 20	93102-19293	9 - 30	95027-06012	10 - 10		26 - 33		
	16 - 15	90467-09006	18 - 18	93102-22800	11 - 3		10 - 12		33 - 14		
90201-105A2	13 - 10		18 - 21	93102-22843	9 - 12		31 - 7	97707-60516	4 - 12		
	13 - 13		18 - 26	93102-32800	12 - 10	95027-06016	1 - 29	97707-60520	4 - 17		
90201-108A3	10 - 8	90467-10041	18 - 16	93104-22086	11 - 30	95027-06020	1 - 15	97707-60530	4 - 8		
90201-12172	9 - 49	90467-12052	6 - 11	93104-41119	11 - 19	95027-06025	9 - 25	98502-04012	7 - 22		
90201-12688	28 - 5		9 - 7	93106-17805	20 - 3	95307-06700	35 - 24	98507-05010	19 - 23		
90201-155G5	10 - 16	90467-13042	1 - 28	93106-28809	16 - 4	95307-10800	16 - 14	98507-05020	5 - 8		
90201-15803	12 - 3	90480-01558	13 - 25	93109-28811	16 - 3	95307-12700	11 - 16		35 - 10		
90201-15831	12 - 2	90480-12497	4 - 15	93210-09802	1 - 4	95604-08200	25 - 10	98507-05035	34 - 9		
90201-168S9	11 - 13	90480-12813	14 - 12	93210-09859	22 - 15	95607-05100	34 - 7	98507-05040	34 - 10		
90201-220J8	22 - 5	90480-13814	13 - 24	93210-14802	22 - 17	95607-06100	34 - 14	98507-06012	35 - 28		
90202-05193	18 - 10	90480-14810	8 - 13	93210-14805	9 - 17	95607-12200	20 - 8	98507-06014	35 - 19		
90202-15803	13 - 15	90501-10312	34 - 15	93210-15862	3 - 24	95617-06625	1 - 8	98507-06016	28 - 3		
90202-26142	17 - 52	90501-16004	5 - 11	93210-26668	29 - 6	95707-05300	33 - 7	98517-05020	34 - 4		
90208-12050	11 - 12	90501-16801	23 - 21	93210-27800	6 - 5	95707-06500	6 - 6	98517-05030	34 - 5		
90249-12008	23 - 20	90501-45801	11 - 22	93210-29800	5 - 12		19 - 19	98707-04012	24 - 5		
90269-06806	15 - 2	90506-13800	22 - 7	93210-43800	11 - 20	95707-10500	22 - 14	98980-06016	8 - 17		
	19 - 10	90506-16801	25 - 21	93210-54008	1 - 17	95807-06010	13 - 22	98980-06020	4 - 13		
90280-03045	2 - 9	90506-16802	22 - 8	93210-55669	29 - 4	95807-06012	19 - 18	99009-15400	10 - 17		
90340-12802	9 - 48	90506-20803	25 - 15	93210-71803	1 - 14		24 - 12	99009-25400	12 - 7		
90380-15817	10 - 15	90506-26802	25 - 22	93211-07801	9 - 31		24 - 13	99009-42500	16 - 6		
90387-061N6	8 - 14	90506-40800	25 - 14	93306-003Y4	9 - 50	95807-06016	14 - 10	99480-05010	9 - 33		
90387-06819	9 - 42	90508-32609	10 - 14	93306-201Y7	20 - 4		19 - 12				
90387-06868	14 - 11	90520-01801	13 - 4	93306-203YS	11 - 4		19 - 21				
	33 - 4	90520-02834	13 - 3	93306-272X0	11 - 2	95807-06030	6 - 26				
90387-068C3	26 - 30	90520-10816	13 - 33	93306-272Y0	12 - 9	9580L-06010	17 - 44				
90387-068F8	14 - 3	90520-20812	13 - 34	93306-301YA	20 - 5	95817-08016	3 - 15				
90387-068F9	4 - 5	91317-05010	23 - 16	93306-301YL	12 - 11		9 - 14				
90387-12852	20 - 10	91317-05014	18 - 27	93306-302X1	16 - 7	95817-08030	13 - 23				
90387-153N8	16 - 5	91317-06012	3 - 23	93306-303Y8	12 - 8	95817-10035	8 - 21				
90387-15813	16 - 8	91317-06016	3 - 21	93306-372Y3	2 - 7	95827-06012	18 - 5				
90387-16801	11 - 10	91317-06025	24 - 7	93306-903Y1	11 - 27		23 - 23				
90401-10805	24 - 9	91317-06030	10 - 19	93310-450X2	10 - 2	95827-08045	16 - 2				
90430-06014	1 - 7	91317-06100	1 - 24	93310-528Y9	2 - 3	97080-06008	8 - 3				
90430-08816	9 - 15	91317-08025	23 - 5	93311-315Y2	12 - 4	97507-06525	29 - 8				
90446-13803	9 - 6	91810-14807	1 - 22	93315-110Y6	10 - 6	97517-06512	1 - 12				
90450-28802	18 - 23		1 - 23	93317-522Y2	11 - 29	97527-06512	35 - 13				
90450-53061	26 - 17		9 - 8	93450-16068	2 - 12	97607-06220	6 - 23				
90464-12812	13 - 18		9 - 20	93450-31834	11 - 28	97607-06225	28 - 4				
	23 - 24		9 - 24	93900-00805	20 - 6	97707-50012	15 - 5				
90464-26800	13 - 36	91A10-07005	18 - 14		22 - 2		15 - 10				
90464-28800	23 - 25	91A11-07048	18 - 13	94112-12802	20 - 7		15 - 12				
90464-30802	35 - 14	92012-05010	30 - 7	94113-12801	22 - 3		25 - 5				
90464-40801	13 - 7		30 - 14	94568-75094	3 - 16		33 - 16				
	35 - 25	92990-06200	8 - 16	94700-00881	1 - 20	97707-50016	14 - 7				
90464-60800	13 - 20	92990-06600	8 - 2	95023-06020	35 - 6		26 - 2				